



OECS SECRETARIAT



---

## SAINT LUCIA

### MACRO SOCIO-ECONOMIC AND ENVIRONMENTAL ASSESSMENT OF THE DAMAGE AND LOSSES CAUSED BY HURRICANE TOMAS: A GEO-ENVIRONMENTAL DISASTER

#### TOWARDS RESILIENCE







UNITED NATIONS



Economic Commission for Latin America and the Caribbean  
Subregional Headquarters for the Caribbean

---

Distr. LIMITED  
LC/CAR/L.286  
7 February 2011  
ORIGINAL: ENGLISH

## **SAINT LUCIA**

### **MACRO SOCIO-ECONOMIC AND ENVIRONMENTAL ASSESSMENT OF THE DAMAGE AND LOSSES CAUSED BY HURRICANE TOMAS: A GEO-ENVIRONMENTAL DISASTER**

#### **TOWARDS RESILIENCE**

---

This document has been reproduced without formal editing.



## PREFACE

This report was prepared on request of the Government of Saint Lucia following the passage of Hurricane Tomas on 30-31 October 2010. The implications of the impact of Hurricane Tomas posed a need, apart from the immediate humanitarian response, for a rapid assessment of the social, environmental and economic effects.

The assessment was carried out using the methodology first developed by the Economic Commission for Latin American and the Caribbean (ECLAC), now known as the Damage and Loss Assessment methodology, or the DaLA.

The assessment will complement and expand on the emergency and humanitarian needs identified previously by the Government of Saint Lucia. The result of such an assessment provides a quantitative approximation of the overall damage to the economy and its impact on the affected population.

Baseline data for the conduct of the macro socio-economic and environmental effects are drawn from among official government data sets including: the Population and Housing Census 2001, the Survey of Living Conditions 2006, other relevant data sets from the Government Central Statistical Offices, Ministry of Finance, and Ministry of Planning and the Eastern Caribbean Central Bank (ECCB).

### **Mission components**

The ECLAC mission, undertaken from 17-24 November 2010, was supported by the United Nations Development Programme (UNDP) Barbados Sub-Regional Office (SRO) and conducted in collaboration with the Organisation of Eastern Caribbean States (OECS) Secretariat, the Inter-American Institute for Cooperation on Agriculture (IICA) and the University of the West Indies (UWI).

The ECLAC Team comprised:

Asha Kambon	ECLAC, Coordinator and Social Sector Specialist
Michael Hendrickson	ECLAC, Macro Economist
Vincent Little	IICA, Agricultural Specialist
David Smith	Coastal Zones and Infrastructure Specialist
Derek Gay	Geo-Technical Engineer, Specialist in the Mass Movement on Slopes
Erik Blommestein	Tourism and Environmental Economist
Ivor Jackson	Human Settlements and Physical Planning

This report was made possible by the cooperation, coordination and support provided by the relevant government authorities and the staff of the OECS Secretariat and the IICA Saint Lucia office. The national counterparts were coordinated by Mr. Embert St. Juste, Director of Policy and Research in the Ministry of Finance, Planning and Development and Chair of the National DaLA Committee.



## Table of contents

<b>Preface</b>	.....	i
<b>Executive summary</b>	.....	vi
<b>I. The event</b>	.....	1
A. Hydro meteorological description.....		1
B. Geo-environmental consequences .....		5
<b>II. The affected population</b>	.....	37
A. The geographic spread of the affected population .....		38
B. The health status .....		40
C. The level of impact on the population .....		41
D. The differing vulnerability of women and men .....		42
<b>III. Description of damage and losses by sector</b>	.....	44
A. Infrastructure.....		44
B. Agriculture .....		63
C. Tourism.....		85
D. The impact on the manufacturing and distribution sectors .....		92
E. Social sector.....		93
<b>IV. The macroeconomic impact of Hurricane Tomas on Saint Lucia</b>	.....	104
A. Summary of impact.....		104
B. Macroeconomic impact of Hurricane Tomas on Saint Lucia .....		106
<b>V. Planning and mitigation</b>	.....	118
A. Settlements.....		118
B. Land use and planning .....		120
C. Mitigation for vulnerability reduction strategies .....		123
<b>VI. Conclusions and recommendations: Building resilience to advance sustainable livelihoods and development</b>	.....	128
<b>VII. Recommendations - B: Period of implementation</b>	.....	138
<b>Annex I</b>	.....	142
<b>Annex II</b>	.....	150

## List of Tables

Table 1: Wind – Rainfall – Pressure Measurements.....	3
Table 2 . Severely affected population by district .....	38
Table 3: No of reported cases by Syndromes, weeks 41-42 2009-2010 .....	41
Table 4: Saint Lucia: Indigence, Poverty and Inequality 1995 and 2005/2006 .....	42
Table 5: Demographic and social characteristics of the population .....	43
Table 6: Description of damage to WASCO equipment and plant.....	48
Table 7: Load Factors for Hewanorra Airport – Arrivals and Departures .....	54
Table 8: Factors for G F L Charles Airport – Arrivals and Departures .....	54
Table 9: Damaged road sections.....	58
Table 10: Affected bridges .....	59
Table 11: Water supply support works .....	59
Table 12: Damage to forest roads .....	61
Table 13: Rivers that require river training.....	61
Table 14: Summary of damage and losses caused by Hurricane Tomas .....	63
Table 15: Rate of growth of GDP by agricultural activity at basic prices in constant prices .....	65
Table 16: Domestic, agricultural and banana exports (EC\$'000), 2005-2009.....	66
Table 17: Land Capability Classes, Total Area and Cultivation Possibilities .....	67
Table 18: General Agricultural Census Results on Farm Holdings, 2007 .....	67
Table 19: Total Number of Holdings by Census Year.....	68
Table 20: Number of Holdings by Administrative District .....	68
Table 21: Total Areas on Holdings by Administrative District (Acres) .....	68
Table 22: Number of Holdings by Holding Size .....	69
Table 23: Distribution of Holding Areas (acres) by Holding Size.....	69
Table 24: Land Tenure Structure (1986, 1996, 2007) – Areas of Holdings .....	70
Table 25: Total estimated damage to the agricultural sector .....	71
TABLE 26: Estimate of damage to the agricultural sector .....	71
Table 27: Estimated loss to the agricultural sector .....	72
Table 28: Banana production, 2007-2010.....	72
Table 29: Total Damage to the Banana Industry .....	73
Table 30: Implications of Hurricane Tomas on Banana Production, Income and Export Earnings .....	73
Table 31: Total damage to the other crops subsector (EC\$).....	74
Table 32: Estimated total damage to the livestock subsector .....	75
Table 33: Estimate of damage to the livestock sub-sector.....	75
Table 34: Estimated loss incurred by the livestock subsector.....	76
Table 35: Total damage to aquaculture.....	77
Table 36: Total damage to fisheries - marine .....	78
Table 37: Total damage to the forestry subsector.....	79
Table 38: Total damage to natural forest by range .....	79
Table 39: total damage to plantation forest by range.....	80
Table 40: Christmas tree plantation damage per range.....	80
Table 41: Forest and trees on private lands outside reserves.....	80
Table 42: Damage to forest and access roads .....	81
Table 43: Trails and other ecotourism facilities .....	82
Table 44: Total damage to infrastructure.....	83
Table 45: Total damage to farmlands .....	83
Table 46: Damage to the agricultural sector by subsector and region .....	84
Table 47: Losses to the agricultural sector by subsector and region.....	84
Table 48: Summary table in the agricultural sector .....	85
Table 49: Saint Lucia Monthly Stay-over Arrivals.....	86
Table 50: Allocation of the loss of tourism expenditures over tourism sub-sectors (2010).....	87
Table 51: Emergency water supplies and costs .....	88
Table 52: Airport shuttles between George F L Charles and Hewanorra (and vice versa).....	88
Table 53: Damages to Attractions and forests .....	90
Table 54: Losses to attractions .....	90



Table 55: Losses due to the removal of debris. ....	91
Table 56: Summary of damages and losses in tourism.....	91
Table 57: The Impact of Hurricane Tomas on the Manufacturing Sector (EC\$ millions).....	92
Table 58: The Impact of Hurricane Tomas on the Distribution Sector (EC\$ millions).....	93
Table 59: Damaged and destroyed houses by District.....	94
Table 60: Selected Characteristics of Dwellers by Communities.....	94
Table 61: Barons drive relocation project, Cresslands.....	95
Table 62: Saint Lucia: Summary table of damage and losses for housing subsector.....	97
Table 63: Health facilities damaged and destroyed by Hurricane Tomas by health regions.....	98
Table 64: Costs of relocation of the Dennery Hospital.....	99
Table 65: Saint Lucia: Summary table damage and losses for health sector.....	99
Table 66: Number of schools damaged by level of institutions.....	101
Table 67: Secondary schools damaged with description of damage and cost.....	102
Table 68: Total number of damaged/destroyed furniture items for the Schools System.....	102
Table 69: Saint Lucia: Summary table damage and losses for the education sector.....	103
Table 70: Summary Damage and Losses from Hurricane Tomas on Saint Lucia.....	105
Table 71: The Fiscal Impact of Hurricane Tomas.....	111
Table 72: The Impact of Hurricane Tomas on the Balance of Payments.....	115
Table 73: Gros Islet/Babonneau Development Applications, January – October 2010.....	120

### List of Figures

Figure 1: Rainfall occurrences versus return period.....	3
Figure 3: Typical weathered volcanic soil/rock profile (Deere and Patton 1971).....	10
Figure 4: Effects of vegetation on slopes (Greenway 1987).....	11
Figure 5: Distribution of affected population and level of vulnerability.....	39
Figure 6: Persons in shelter.....	39
Figure 7: Injuries suffered.....	40
Figure 8: Distribution of affected population by level of impact.....	41
Figure 9: Distribution of WASCO accounts.....	44
Figure 10: Distribution of the impact on the infrastructure sector.....	63
Figure 11: Real growth rate in GDP (2006-2010).....	64
Figure 12: Contribution of the various subsectors to agricultural GDP.....	65
Figure 13: Distribution of damage by level of educational institutions.....	103
Figure 14: The impact of Hurricane Tomas on Real GDP Growth.....	108
Figure 15: Selected mitigation measures against hazard damage.....	124

### List of Maps

Map 1: Storm track and development of Hurricane Tomas, colours represent varying intensifications.....	2
Map 2: Map of reconnaissance routes taken to observe major landslide damage, weather stations in red.....	7
Map 3: Location of houses destroyed by Hurricane Tomas.....	37
Map 4: LUCELECA line distribution network.....	51
Map 5: Sections of roadway affected by the storm.....	55
Map 6: Damage households by poverty.....	96
Map 7: Health regions.....	100

## EXECUTIVE SUMMARY

Hurricane Tomas left a footprint of destruction and death as it swept across Saint Lucia. Seven persons were reported to have lost their lives, five were missing and 36 suffered a variety of physical injuries. Moreover, the hurricane occurred just as the economy was recovering from the fall-out of the recession in major markets, thus complicating the recovery process.

The total cost of the damage and losses to the different sectors amounted to EC\$907.7 million or US\$336.2 million. The scale of the event can be gleaned from comparing the total impact with key economic indicators. The total impact represents 43.4% of GDP, nine times agricultural GDP, three times tourism GDP, 62% of exports of goods and services, 19% of gross domestic investment and 47% of public external debt.

On 31 October 2010, Hurricane Tomas passed just 29 miles (46.7 km) south of the island, as an intensifying cyclone, producing 92 mph (148 km/h) winds on the island<sup>1</sup>. Later in the day, it became increasingly better organized, and reports indicated that the winds increased to 100 mph (160 km/h), a Category 2 hurricane on the Saffir-Simpson scale. An analysis of the deep water waves that would have been generated by Hurricane Tomas revealed that, from a statistical perspective and based on a review of NHC data from 1930 to 2008, this event gave rise to waves that were equivalent to a 1:15 year event. Hence, by any measure, this event can be considered an extreme hydrological event. In civil engineering practice, infrastructure and flood mitigation designs are typically carried out to 1:25 year to 1:50 year return periods.

A brief investigation of the most recent climatic conditions in Saint Lucia suggested that a drought condition preceded this unusually high rainfall event. Whereas the return period of the rainfall was of the order of 180 years, the likelihood of a drought to be followed by a storm event of this magnitude is even more unusual, probably with a return period of over 1000 years.

The drought conditions in Saint Lucia, therefore, set the stage for extremely high potential for surface erosion and mass movements on slopes in the event of a normal rainy period. Even if the rainy season were to be of normal levels the effect of the drought on the soil/rock regime would have resulted in a severe hazard condition in respect of mass movements on slopes (a state that landslide hazard maps could not adequately represent). In fact, the Met Office in Saint Lucia was informed by Caribbean Institute for Meteorology and Hydrology (CIMH) that in terms of total daily rainfall, this event was classified as a 1-in-180-year event, making Hurricane Tomas a very extreme event with regards to rainfall, and well in excess of a 100-year event.

The data, as collected by the National Emergency Management Organization (NEMO), the Red Cross and the Ministry of Housing, suggest that some 5,952 persons, or 3.5% of the national population were severely affected as a result of Hurricane Tomas. The majority of the affected population, some 28% or 1,709, could be found in the district of Castries in the suburban/rural area which, when combined, has the largest population of all the Districts in Saint Lucia and a significantly high proportion of persons classified as vulnerable (16.8%). Another 16.6% or 986 of those severely affected could be found in Soufriere which has the highest proportion of Saint Lucians defined as poor but not indigent (42%); and 15.3% or 909 of those affected could be found in Micoud which has a significant proportion of persons defined as vulnerable (13%).

---

<sup>1</sup> Berg/Franklin (2010-10-31). ["Hurricane Tomas Discussion Eight"](#). National Hurricane Center.

The report identifies four groups of the population, the primary, the secondary, the tertiary and those not affected. The primary group comprising 3% of the total population or 5,952 persons represent those who were affected due to the damage and destruction caused to their homes by Hurricane Tomas. The secondary group, of 1% or 1330 farmers, represents those who were affected because their livelihood, particularly production of banana, was severely affected by the devastation to their crops and land used for cultivation. This proportion is grossly underestimated as all data for other agricultural producers have not yet come to hand. The tertiary group, of 80% or 137,896, represents the proportion of the population who were without potable water for a period of roughly two weeks following the event. The last group of 16% represented those who would not have been directly affected by the event. It can be concluded from this analysis that although a small proportion of the population was severely affected by Hurricane Tomas, it had a widespread secondary effect of restricting persons' access to potable water over a significant period of time. It is a credit to the resilience of the Saint Lucian population and its health sector that no major outbreak of water borne diseases occurred. However, data from the Ministry of Health suggests that there was a 47% increase in under-5 gastroenteritis for 2010, over the 2009 figures, much of this may be attributable to the effects of the water situation caused by Hurricane Tomas. The Report concluded that the high proportion (44%) of female headship nationally and a higher still proportion among the low/middle income households (47%), increased the vulnerability of female headed households to the ravages of Tomas.

Hurricane Tomas exposed the vulnerability of the population and its economic activities to the accessibility of water, as the Roseau Dam experienced land and flow slides into the reservoir area of the dam and damage to its back-up generator and pump house. The turbidity of raw water was increased and the storage capacity of the dam compromised. For a two-week period, water became a scarce commodity, leaving some 80% of the population struggling to cope with a limited supply of potable water. The water authorities sought to supplement the water supply through trucking.

The report concludes that Hurricane Tomas was primarily a damage event and, as such, this combined with the fact that it took place late in the year would help to contain the fall-out in GDP.

Damage to capital assets and stock comprised 67% of the total impact, with losses that affected value added accounting for the balance. The profile of the impact indicated that the infrastructure sector was the most heavily affected, representing 43% of the total impact, however, the productive sectors and social sectors also suffered significant impact. Within the infrastructure sector, the water supply and water disposal systems were severely disrupted with heavy siltation of the main Roseau Dam. The report noted that in general, the water supply and distribution utility has fairly old infrastructure and hence most of this infrastructure is already compromised in terms of efficiency and effectiveness. In addition almost every single intake structure and associated equipment was damaged and silted up as a result of the hurricane. As a result, the cost to the water supply, disposal and works subsector is estimated at EC\$124.47 million, representing 32% of the fall-out in the infrastructure sector and 14% of the total impact. The diversion and siltation of main rivers will also incur substantial costs in river training and desilting. Major damage and destruction to the transport network (roads and bridges), including forest roads, conservatively estimated at EC\$141.7 million (15.6% of the total impact), is an important cause for concern as it would entail substantial costs to rebuild them to an upgraded standard to withstand an event of a reasonable magnitude. Fortunately, the impact on the telecommunications sector was contained to EC\$10 million. Similarly damage and losses in the electricity subsector were relatively modest at EC\$8.3 million, limiting the disruption to business and the lives of persons from this sector.

The productive sectors suffered important disruption that would affect the growth in real output in 2010, but with limited carry-over into 2011. The total impact on the sector amounted to EC\$306.8 million (34% of the total). The mainstay tourism sector suffered the brunt of the effects on the productive sectors, amounting to EC\$114 million, fully 37% of the impact on the sector.

The main tourist hub in Soufriere and Vieux Fort were badly affected by the hurricane, suffering heavy flooding. Fortunately, however, only a few hotels suffered major structural damage. Meanwhile, in the north of the island structural and landscaping damage to hotels was contained, allowing for only temporary disruption of operations in the case of some properties. Losses in the tourism sector stemmed directly from damage to hotels that led to cancellation of some bookings and indirectly from the disruption of water supply that affected operations. Tourism is by any measure the single most economically significant sector in Saint Lucia. A 2009 Tourism Satellite Account prepared for Saint Lucia revealed that 64% of Saint Lucia's economic output is either directly or indirectly attributable to tourism. The core (direct only) tourism sector contributes approximately 30% to Saint Lucia's GDP, making it the top ranked sector in the economy. Preliminary figures for 2009 indicate that tourism activity injected just over EC\$1 billion into the Saint Lucia economy.

The agricultural sector is a critical sector to the economy of Saint Lucia and although its contribution to GDP over the last five years has fluctuated, with an upward tendency, the sector continues to play an important role in the country's socio-economic development. The sector plays a multi-functional role in earning foreign exchange, generating employment and contributing towards economic growth and food and nutrition security. The sector, suffered damage to the tune of EC\$151.8 million. The banana crop was severely disrupted with whole fields being destroyed by the flooding and, to a lesser extent, wind damage. Moreover, the plants that remained standing are expected to produce significantly reduced yields during the next crop. In addition, the fields would require major resuscitation investments in clearing, silt removal, fertilization and drainage to restore harvests to pre-Tomas levels.

Although less than the other key sectors, the social sectors suffered important damage and losses, amounting to EC\$209.2 million, 23% of the total impact. Housing bore the brunt of the fall-out in the social sector with estimated total effect of EC\$192 million, 92% of the impact in the sector. A large number of houses in Castries, Soufriere and Micoud, in particular, were badly damaged or destroyed. A number of those houses were owned by medium income earners and were, therefore, fairly more costly than those owned by low-income households. The report notes that insurance coverage was low, not exceeding 12% in the most affected areas.

The impact on the education sector amounted to EC\$8.9 million. Some 63 schools suffered significant damage mainly from flooding, while some others had damage to their roofs and ceilings. However, the limited structural damage served to limit the total costs of the effects on the education sector. The health sector was impacted to the tune of EC\$8.3 million. A number of hospitals were damaged, particularly the Dennery Hospital, which accounted for half of the cost of the impact in the sector and has to be relocated.

## **Conclusions and recommendations**

The report notes the predictions of Caribbean scientists and their global counterparts that Saint Lucia and other Caribbean States are in a position of increased vulnerability to the effects of climate change. Predictions of higher temperatures, rises in sea level, and increased hurricane intensity which will threaten lives, property and livelihoods throughout the region resonate in a real way with Saint Lucians following Hurricane Tomas.

In response the report suggests that the key action necessary for effective adaptation to climate change, mitigation and risk reduction is the delivery of coherent national development plans that seek to address the new challenges. This report, therefore, provides a series of recommendations which can be

implemented at the national and community levels and across sectors. In addition, the recommendations speak to institutional, legal and policy mechanisms that could be developed or strengthened.

To advance Saint Lucia's capacity for reconstruction and long-term development in the aftermath of Hurricane Tomas, the Report proffers a number of recommendations. For ease of reference the recommendations are presented in two categories for implementation: (a) by the sectors to which they refer; and (b) by period of implementation i.e. short, medium and long term. Recommendations presented very often embody cross-cutting issues, and, therefore, reference to them may be found in a number of sectors. The most important such issue is that of water, which is referenced in the affected population, health, infrastructure, tourism and the environment. Although, in the sectoral discussion recommendations are slightly fleshed out, they are meant only to act as a guide for public policy, programme and project development.

Recommendations have been suggested to address the macroeconomic needs, to respond to the geo-environmental consequences of Hurricane Tomas, the damage to the infrastructure, particularly to water, roads and bridges, in regard to agriculture, including forestry and fisheries, the environment and the tourism sector. With regard to the social sectors and the affected population, recommendations are both targeted at long-term transformation and short-term mitigation actions. Finally, recommendations are presented to address data management for land use planning.

Standing out for immediate action are the following:

- (a) Bathymetric Survey of the Roseau Dam;
- (b) Undertake slope stabilization and river training exercises;
- (c) Embark on reforestation exercises;
- (d) Relocation of Dennery Hospital;
- (e) Retrofitting of public buildings such as schools and health facilities affected;
- (f) Establish small grant/loans for households affected by Hurricane Tomas;
- (g) Establish water harvesting programme;
- (h) Develop and implement an agricultural land use and water management plan; and
- (i) Build capacity at the Physical Planning Office for the preparation of national plans and for monitoring and enforcement of land development policy

The report recommends that central to the success of recovery and reconstruction, efforts would be needed to: seek debt restructuring, relax the fiscal stance, elaborate a national recovery plan, and establish a special unit within its Economic Planning Unit to guide the overall plan with the implementation occurring at the sectoral level.

# I. THE EVENT

## A. HYDRO METEOROLOGICAL DESCRIPTION

The system started as a tropical wave that exited on the western coast of Africa on 25 October 2010, and was soon embedded within the Inter-tropical Convergence Zone<sup>2</sup>. Moving quickly westward, the system contained scattered areas of strong convection, or thunderstorms, as well as a broad circulation<sup>3</sup>. The National Hurricane Centre (NHC) first mentioned the wave in its Tropical Weather Outlook on 27 October when the system was located about 1200 miles (1940 km) east-southeast of the Lesser Antilles. At the time, the agency assessed a 10% chance for tropical cyclogenesis within 48 hours, noting that conditions would become more favourable for development in a few days.<sup>4</sup> By 28 October, the system had become better organized, with a large area of convection. On 29 October, hurricane hunters reported a developing surface circulation with tropical storm force winds.<sup>5</sup> As a result, the NHC initiated advisories on Tropical Storm Tomas late on 29 October when the system was about 290 miles (470 km) east-southeast of Saint Vincent and the Grenadines.<sup>6</sup>

Upon being classified, Hurricane Tomas was in an area of low wind shear and high moisture, both of which support rapid intensification. At the time, the lower-level and upper-level circulations were not vertically aligned, which was expected to result in slow strengthening. At that time, the NHC forecast indicated that Hurricane Tomas was expected to attain hurricane status within 36 to 48 hours. Within three hours after it was classified, however, the winds had already increased to 60 mph (95 km/h).<sup>7</sup> The outflow became well-established in all quadrants as deep convection increased into a prominent rain band. Radar on Martinique indicated that an eye was forming, and Hurricane Tomas continued west-northwestward toward the Lesser Antilles, steered by a ridge to its north<sup>8</sup>. While located only 35 miles (55 km) east of Saint Vincent and the Grenadines, Hurricane Tomas attained hurricane status, based on Hurricane Hunters recording surface winds of 75 mph (120 km/h). At the time, the eye was from 35–46 miles (56–74 km) in diameter.<sup>9</sup>

On 31 October, Hurricane Tomas passed very near to Saint Lucia, just 29 miles (46.7 km) south of the island, as an intensifying cyclone, producing 92 mph (148 km/h) winds on the island<sup>10</sup>. Later in the day, it became increasingly better organized, and reports from the Hurricane Hunters indicated that the winds increased to 100 mph (160 km/h), a Category 2 hurricane on the Saffir-Simpson scale. Concurrently, the storm was being impacted by south-westerly wind shear, which computer models forecasted to increase and which would have served to dampen the development of the system. As a result, Hurricane Tomas weakened as the convection waned near the centre, due to the shear and dry air, and by 1 November had diminished to tropical storm<sup>11</sup> status. The storm was described as a "highly sheared tropical cyclone", because the circulation became dislocated from the convection by more than 100 miles (160 km). The winds were estimated, therefore, to have decreased to 45 mph (75 km/h) by that time, although an area of thunderstorms reformed northeast of the centre<sup>12</sup>. The subsequent day the

---

<sup>2</sup> Patricia Wallace (2010-10-25). "[Tropical Weather Discussion](#)". National Hurricane Center.

<sup>3</sup> Patricia Wallace (2010-10-25). "[Tropical Weather Discussion](#)". National Hurricane Center.

<sup>4</sup> Pasch/Kimberlain (2010-10-27). "[Tropical Weather Outlook](#)". National Hurricane Center.

<sup>5</sup> Stewart/Cangialosi (2010-10-29). "[Special Tropical Weather Outlook](#)".

<sup>6</sup> Stacy Stewart (2010-10-29). "[Tropical Storm Tomas Discussion One](#)". National Hurricane Center.

<sup>7</sup> Berg/Brown (2010-10-30). "[Tropical Storm Tomas Special Discussion Two](#)". National Hurricane Center.

<sup>8</sup> Michael Brennan (2010-10-30). "[Tropical Storm Tomas Discussion Four](#)". National Hurricane Center.

<sup>9</sup> Berg/Brown (2010-10-30). "[Hurricane Tomas Discussion Three](#)". National Hurricane Center

<sup>10</sup> Berg/Franklin (2010-10-31). "[Hurricane Tomas Discussion Eight](#)". National Hurricane Center.

<sup>11</sup> Robbie Berg (2010-11-01). "[Tropical Storm Tomas Discussion Twelve](#)". National Hurricane Center.

<sup>12</sup> John Cangialosi (2010-11-01). "[Tropical Storm Tomas Discussion Fourteen](#)". National Hurricane Center.

structure became better organized with more deep convection over the centre due to lighter shear and a moister environment. By that time, it was passing just north of the ABC Islands.<sup>13</sup>

Map 1 shows the track of this system through the Caribbean and as well depicts the changes in strength along its trajectory.

**Map 1: Storm Track and development of Hurricane Tomas, colours represent varying intensifications**

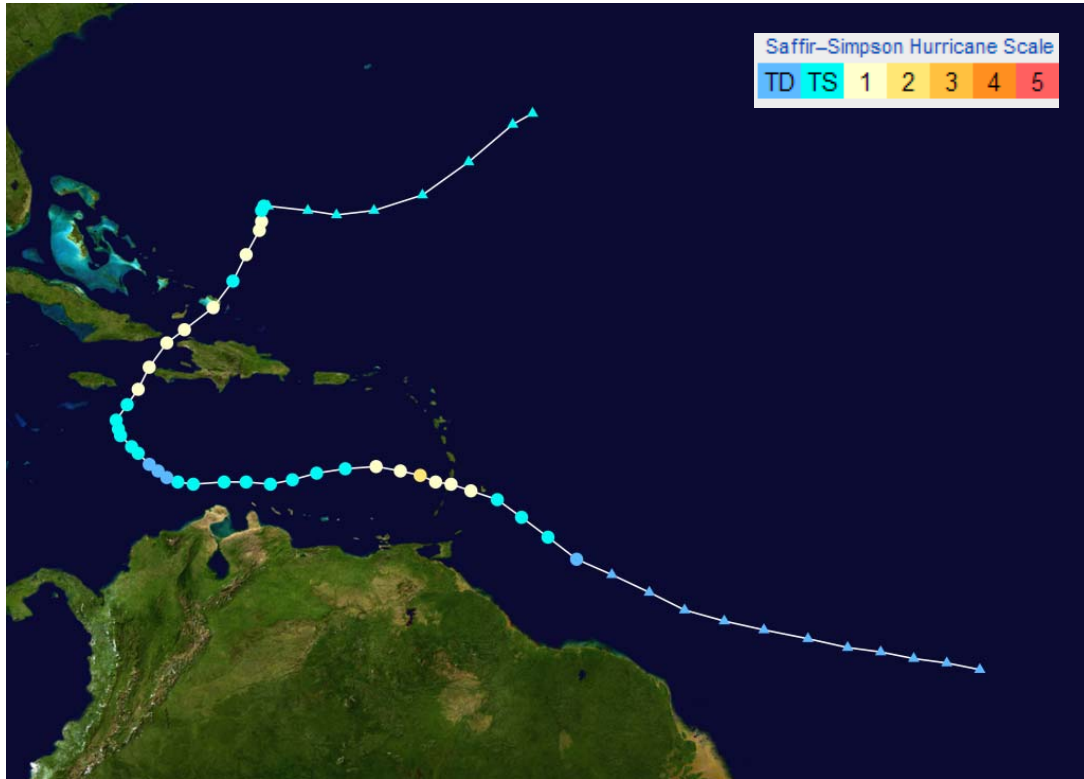

## 1. RAINFALL RECORDS

Rainfall records were obtained from CIMH, based in Barbados. Table 1: shows the records for five measuring stations. Of the five stations gauged, Desraches received the most rainfall in a 24-hour period, 668 mm between 8 a.m. on Saturday 30 October 2010 and 8 a.m. Sunday 31 October 2010.

<sup>13</sup> Cangialosi/Brown (2010-11-02). "[Tropical Storm Tomas Discussion Eighteen](#)". National Hurricane Center.

Table 1: Wind – Rainfall – Pressure Measurements

Station	Maximum Sustained Winds			Maximum Wind Gust			Total Rainfall (mm)	Minimum SL Pressure	
	Dir.	Speed (km/h) 10 min	Local time	Dir.	Speed (km/h)	Local Time		Pressure (hPa)	Local Time
Hewanorra Airport	ENE (070 deg)	143 or 89 mph.	15:15 – 15:25	ENE	157 or 98 mph.	15:17	593.1 (23.4")	997.8	15:26
GFL Charles Airport*	E (093)	56.2 or 35 mph.	20:50 – 21:00	E	101 or 62 mph.	20:50	533.3 (21.0")	1003.8	16:00
Anse la Raye	-	-	-	-	-	-	405.0 (15.9")	-	-
Desraches	-	-	-	-	-	-	668.0 (26.3")	-	-
Forestier	-	-	-	-	-	-	635.0 (25.0")	-	-

Source: ECLAC

The information presented in table 1 has been augmented by hourly records at a number of sites. For example at Forestier, 452mm of rain was recorded between 0100 hours and midnight on 30 October 2010. At Anse-La-Raye over the same period, 234 mm were recorded.

Figure 1 shows an extremal analysis of total daily rainfall (in mm) carried out on 10 years of data (2000 – 2009) at George F L Charles Airport. It can be seen that the 1:100 year daily rainfall for this location was estimated to be 155 mm, therefore, indicating that Hurricane Tomas was a very extreme event with regards to rainfall, and well in excess of a 100-year event. In fact, the Met Office in Saint Lucia was informed by CIMH (personal communication, Mr. Descartes at the Met Office, Vieux Fort) that in terms of total daily rainfall, this event was classified as a 1:180-year event.

Figure 1: Rainfall occurrences versus return period

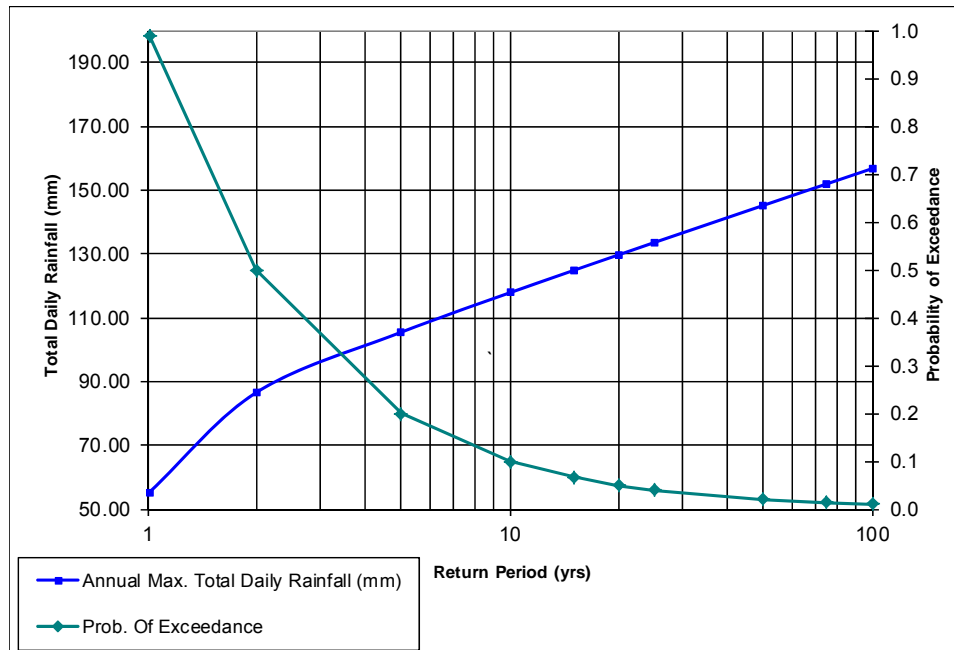



## 2. STORM WAVES

An analysis of the deep water waves that would have been generated by Hurricane Tomas has revealed that from a statistical perspective, and based on a review of NHC data from 1930 to 2008, this event gave rise to waves that were equivalent to a 1:15-year event.

## 3. OVERVIEW OF IMPACTS

At an initial meeting held at the offices of the OECS, on Wednesday 17 November 2010, an overview of impacts resulting from the storm was obtained. In summary, the impacts of the hurricane across the various sectors of the island were presented as follows:

- (a) Road and bridge infrastructure were severely impacted from flooding and from landslides.
- (b) Housing located adjacent to unstable slopes were impacted badly. In addition to slope failure occurrences, some evidence of wind damage was apparent.
- (c) There was significant damage to the water sector, and in particular to the Roseau Dam, which suffered minor structural damage but had major siltation inputs from land slippage along the sides of the dam.
- (d) Agriculture was severely affected.
- (e) In the educational sector, schools were damaged by winds and landslides.
- (f) Rivers were affected in terms of their alignment and carrying capacity.
- (g) Within the health sector, the Dennery and Soufriere Hospitals were damaged.
- (h) There was some damage to the electricity sector.
- (i) The telecommunications sector suffered some infrastructural damage.
- (j) The effect on tourism infrastructure appeared to be limited, although there were issues with access in the south.
- (k) Underwater surveys carried out by the Soufriere Marine Management Area (SMMA) and Canaries Anse La Ray Marine Management Area (CAMMA) show some sedimentation but relatively minor damage to ecosystems. Also, the beaches around the island seem not to have suffered badly.
- (l) At the time of the meeting, the confirmed number of deaths from this event was eight most of which were landslide related.

## **B. GEO-ENVIRONMENTAL CONSEQUENCES**

### **1. INTRODUCTION**

Observations of damage sustained over the island of Saint Lucia as a result of the passage Hurricane Tomas appears to be dominated by the effects of rainfall as opposed to wind speed, the traditional hurricane hazard. Hurricane Tomas began life as a tropical depression, then tropical storm and was only upgraded to Category 1 hurricane over the island of Barbados on 29 October 2010, prior to making landfall in Saint Lucia on 30 October 2010. Rainfall records over Saint Lucia (detailed elsewhere in report) suggests that rainfall over a 24-hour period 30 -31 October 2010, varied between 16 inches and 26 inches with preliminary statistics of this event suggesting this level of rainfall to be a 1:180 year return period event. These locations are indicated in figure 2, where the proximity of the main damage centres can be appreciated. Hence, by any measure, this event can be considered an extreme hydrological event. In civil engineering practice, infrastructure and flood mitigation designs are typically carried out to 1:25 year to 1:50 year return periods.

In this case, the occurrences and effects of flooding and landslides (the term used here to describe the collective of all mass movements on slopes, to include rotational, translational, flow slides, debris slides, rock falls and mud slides, appear to dominate the landscape of damage. The environment as it was known, changed forever. In all natural earth environments, the processes of flooding and mass movements on slopes are part of the natural process of weathering as gravity takes its toll on all masses located away from its centre of mass (the middle) of the earth. A perfectly natural process becomes a “disaster” only upon its encounter with the demands of man.

Rainfall, its intensity and duration would have provided the initial trigger to saturate and modify the internal matrix of soil/rock, and landslides and fast flowing silt/rock-laden waters would result. Had an event of this type occurred over a purely urban landscape where runoff over paved surfaces would dominate over infiltration, the net result would be flooding of such areas with relatively “clean” debris-free waters. However, in Saint Lucia this is not the case as such urban centres are uncommon. The dominant landscape of Saint Lucia is one of exposed and vegetated soil and rock surfaces on steep slopes, even in the densely populated suburban areas of Greater Castries (areas to the east and southeast of Castries, The Morne to Babonneau).

In such cases, the effect of rainfall infiltration into the particulate matrix of the near-surface soil/rock strata invariably leads to rapid changes in pore water pressures from negative suction state (holds the matrix/grains together, think sand castle sand) to a positive pressure state that tends to “float” the soil grains resulting ultimately in fluidization and slurry formation. This change is generally accompanied by a significant and rapid reduction in soil/rock strength, where the solid particulate mass matrix transforms into a viscous fluid, giving rise to rapidly moving flow slides, debris flows and mudslides. It is, therefore, difficult to assign a single descriptor to the movement of earth masses on slopes as such instability can typically begin as a rotational or translational unsaturated soil landslide and end up as a debris/earth/mud/flow slide, where it is impossible to discern its true genesis.

The depth and rate at which infiltration occurs are largely dependent on the initial moisture status of the soil/rock. During drought conditions, soils typically experience lower than normal moisture contents and greater air-filled voids over greater depths, as evaporation and transpiration by vegetative cover results in moisture deficits. As a consequence, with the onset of rains following a drought, rapid infiltration is likely and to depths greater than that associated with the “normal” dry-rainy season cycle. A brief investigation of the most recent climatic conditions in Saint Lucia suggests that a drought condition preceded this unusually high rainfall event. Whereas the return period of the rainfall was of the

order of 180 years, the likelihood of a drought to be followed by a storm event of this magnitude is even more unusual, probably with a return period of over 1000 years.

The drought conditions in Saint Lucia, therefore, set the stage for extremely high potential for surface erosion and mass movements on slopes in the event of a normal rainy period. Even if the rainy season were to be of normal levels, the effect of the drought on the soil/rock regime would have resulted in a severe hazard condition in respect of mass movements on slopes (a state that landslide hazard maps could not adequately represent).

## **2. RECONNAISSANCE SURVEYS: ASSESSMENT OF DAMAGE**

Reconnaissance surveys were carried over the period 20-22 November 2010. These included an aerial survey by helicopter and overland surveys on roadways and paths. These reconnaissance survey paths and areas of significant damage are illustrated in map 1.

The ECLAC team also utilized preliminary damage assessment reports from The Ministry of Works and Infrastructure, NEMO and the Association of Professional Engineers of Saint Lucia (APESL). These were obtained through the office of the OECS.

### **(a) Areas with significant landslide damage**

- (a) The Morne - Bagatelle – Guesneau – Trois Pitons- Forestierre –Bocage - Babonneau
- (b) Bexon – Marc – Ravine Poisson
- (c) Barre de L'Isle - Thomazo – Grande Rivere
- (d) John Compton/Roseau Dam – Vanard – Millet
- (e) Fond St Jacques
- (f) Cresslands Development
- (g) Colombette

### **(b) Areas with significant river/bridge damage/siltation/flooding**

- (a) Bois D'Orange Bridge
- (b) Choc Bridge
- (c) Patience Culvert/Bridge
- (d) Soufriere River/Bridge
- (e) Anse Galet River/Culvert crossing
- (f) Cresslands Development.
- (g) Bexon Marc River valley

Map 2: Map of reconnaissance routes taken to observe major landslide damage, weather stations in red



(c) **Area 1: The Morne, Bagatelle, Guesneau, Forestier, Trois Pitons, Bocage, Babonneau**

Although the major damage in this area are from the Bagatelle, Guesneau and Trois Pitons landslides, there are many smaller slides mainly along roadways and in cut terraces for buildings, which have to be stabilized as they could become the trigger for potentially larger movements.

This area to the east of Castries is predominantly developed, with houses and infrastructure typically along roadways that follow the tops of winding ridges interconnected by steep switchbacks and slopes. The soil type in this area appears to be deeply weathered basaltic and andesitic intrusions with near-surface basement rock. This terrain is vulnerable to landslides as it comprises primarily residual soils (sands, silts and clays) frequently overlying fissured basement rock. As a consequence, rapid and continuous infiltration can result in the development of transient perched water tables (saturated conditions) in an otherwise unsaturated and well drained soil environment. Infiltration into fissured basement rock also leads to the development of artesian water pressures, which frequently manifest at the ground surface as springs and sinkholes. In the areas of Bagatelle, Guesneau and Trois Pitons, springs were observed within the landslide areas.

Although the Bagatelle slides did not result in complete loss of the roadway, upslope land slippage, predominantly rotational and translational, has occurred up to the building line of many buildings, making these un-inhabitable. The location of Victoria Road on the ridge crest above the

Bagatelle Road makes this ridge road vulnerable to further slippage. This slide area appears to have been triggered by a combination of natural surface flows and infiltration and manmade sources, in the form of roof storm water and septic tank soak-aways. There is also observable evidence of historical down-slope creep movement in this area

The slippage in the Guesneau area is characterized by a major slippage over a roadway section of approximately 150 metres. Seven houses perished in this landslide as the predominantly translational landslide/flowslide extended from the building line below the ridge to approximately 200 metres downslope into the valley. This slide also appears to have been triggered by a combination of natural surface flows/infiltration and man-made sources in the form of roof storm water, roadway stormwater and septic tank soak-aways.

The Trois Pitons landslide appears to be a composite translational-flow slide from where saturated top soils appear to have slid over basement rock. This slide appears to have been predominantly triggered by natural surface flows and infiltration.

The landslide hazard map for this area classifies the risk as moderate to low.

Figure 2

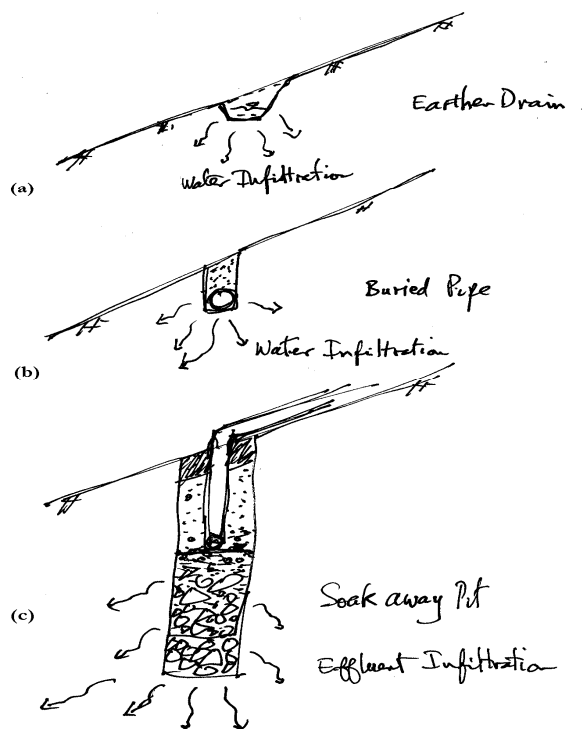

Man-made water sources that contribute to direct water injection into slopes, negatively impacting stability.

**(d) Area 2: Bexon, Marc, Ravine Poisson**

The slopes in this area are predominantly deeply weathered, esitic and basaltic intrusions over fissured basement rock and/or weathered ash or pyroclastics over basement rock. These deeply weathered formations are typically characterized by an upper layer of lightly cemented clay and silt-sized residual soils over fissured basement rock. The natural slopes are the shallowest of the failed areas, typically between 25° and 35° (with locally steeper areas at road cut sections and recent landslides). A significant

characteristic of this soil/rock domain is the presence of a weathered surface soil horizon, generally thick (3-6 m) and comprising predominantly silts and clays of high porosity, that are readily fluidized upon saturation. Rotational, translational and flow slides dominate in this landscape. The vegetation in this area is predominantly forest cover, with frequent interventions of banana and subsistence farming cultivations on the slopes.

The area has a history of damaging landslides, the most notorious of which is the Ravine Poisson mudslides in 1938 in which 60-100 persons perished.

In the Marc and Ravine Poisson areas, houses most vulnerable to landslides were those found in cut/benched slopes against hillsides above which crops were cultivated up to their ridges. Buildings constructed on the banks/flood plain or the Ravine Poisson and Bexon Rivers also became highly vulnerable as the rivers undercut sections of their banks, destabilizing foundation soils.

Although the historical landslide in the Ravine Poisson area in 1938 resulted in loss of life with the slide occurring over a relatively large area, the landslide hazard map for this area classifies the risk as moderate to low. This underscores the inability of such maps to represent data on the local scale, where event analysis would be more meaningful.

**(e) Area 3: Barre de L'Isle, Thomazo, Grande Rivere**

The heavily trafficked West Coast Road (Castries – Vieux Fort) climbs steeply up the Barre de L'Isle Ridge from Ravine Poisson and over the ridge to Thomazo and Grande Rivere. This area is characterized by steep to near vertical cut sections in residual soil/rock volcanic profiles as illustrated in figure 3.

Figure 3: Typical weathered volcanic soil/rock profile (Deere and Patton 1971)

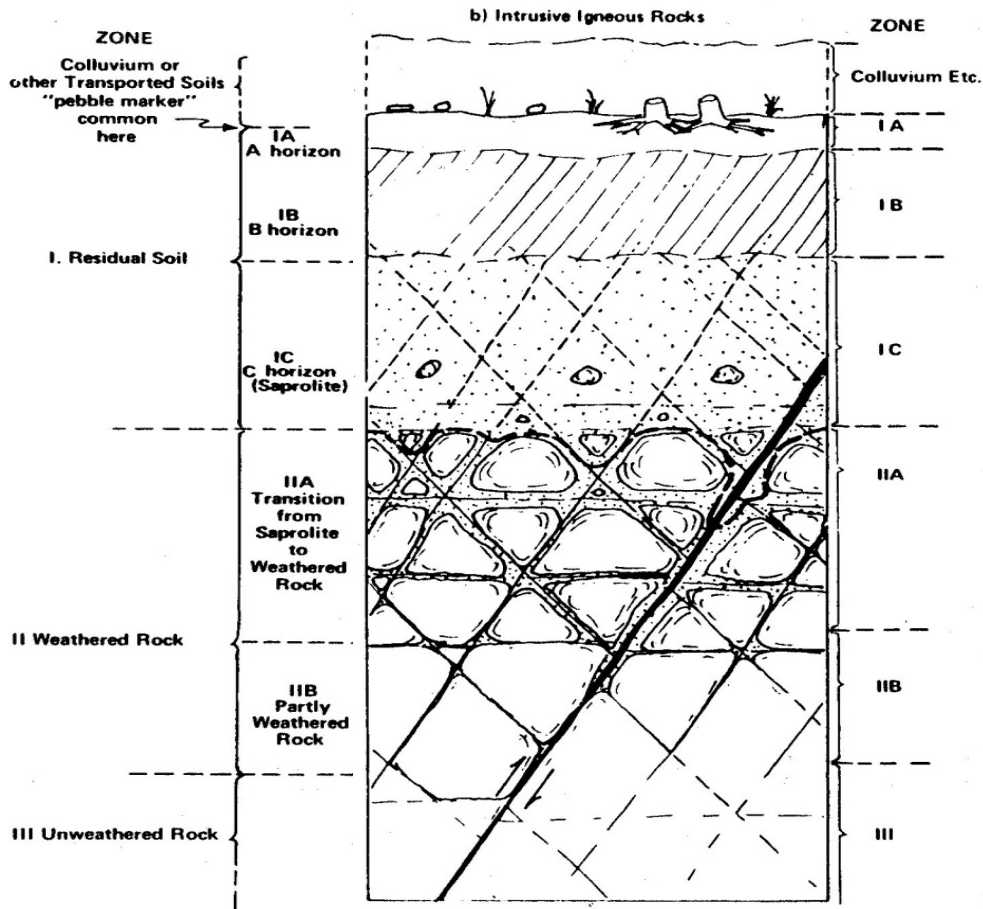

These slopes give rise to frequent landslides even during normal rainy season events as the exposed residual soils' profiles become vulnerable to saturation, loss of strength, erosion and sliding.

Many landslides were observed on both cut up-slope sections and the hanging down-slopes off the roadway edge. The proliferation of tropical rainforest tree cover within the roadway right of way, while providing shade and a green aesthetic footprint, also serves to destabilize the soil and rock cover. The effect of trees and roots on slope stability has been summarized succinctly by Greenway (1987) as illustrated in figure 4. As trees grow and their canopies extend, they trap/intercept wind resulting in oscillatory/rocking motion which, when transmitted to their roots, serves to loosen the soil reducing strength and increasing infiltration potential.

Figure 4: Effects of Vegetation on Slopes (Greenway 1987)

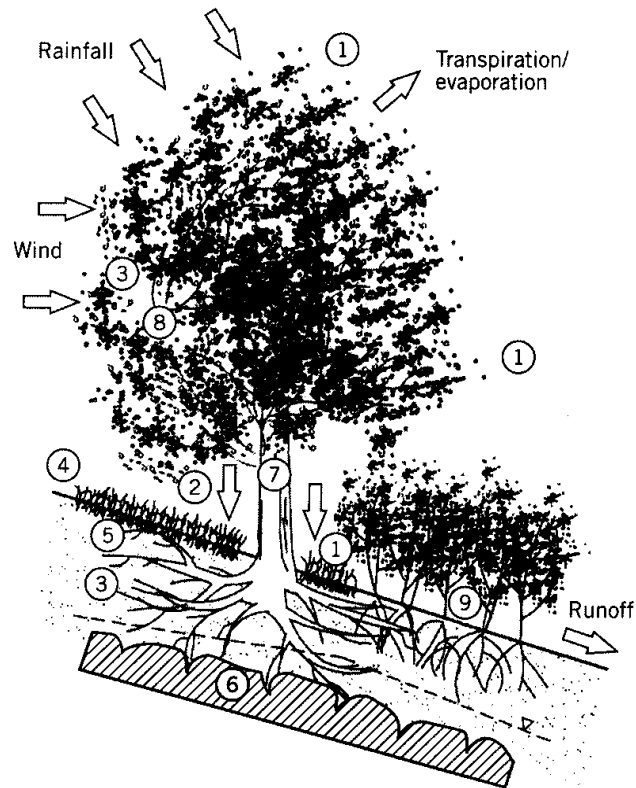
**Hydrological mechanisms**

		<b>Influence</b>
①	Foliage intercepts rainfall, causing absorptive and evaporative losses that reduce rainfall available for infiltration.	Beneficial
②	Roots and stems increase the roughness of the ground surface and permeability of the soil, leading to increased infiltration capacity.	Adverse
③	Roots extract moisture from the soil, moisture that is lost to the atmosphere via transpiration, leading to lower pore water pressures.	Beneficial
④	Depletion of soil moisture may accentuate desiccation cracking in the soil, resulting in higher infiltration capacity.	Adverse

**Mechanical mechanisms**

⑤	Roots reinforce the soil, increasing shear strength.	Beneficial
⑥	Tree roots may anchor into firm strata, providing support to the upslope soil mantle through buttressing and arching.	Beneficial
⑦	Weight of trees surcharges the slope, increasing normal and downhill force components.	Adverse/Beneficial
⑧	Vegetation exposed to wind transmits dynamic forces into slope.	Adverse
⑨	Roots bind soil particles at the ground surface and increase surface roughness, thereby reducing susceptibility to erosion.	Beneficial



**(f) Area 4: John Compton/Roseau Dam, Vanard, Millet**

The Roseau Dam experienced local landslides along the access roadway and a major slide that damaged its back-up generator and pump house. Its connector line from the Millet storage facility also suffered damage, due principally to river bank land slippage and erosion.

By far the most significant damage to the water supply system would be the numerous land and flow slides into the reservoir area of the dam over its length, that have the capacity to immediately reduce the storage capacity and increase the turbidity of the raw water. The reservoir area of the dam is relatively narrow, as far as dams go, and, as such, cumulative volumes of silt and earth debris could compromise its capacity. The tributary rivers into the dam are all heavily sited from flow slides. Water and Sewerage Company Limited (WASCO) personnel indicate a similar phenomenon occurred during Hurricane Debbie 1994 and that debris has never been cleared.

**(g) Area 5: Fond St Jacques**

The flow slides in the Fond St Jacques area are perhaps the most dramatic, by virtue of their sheer scale and volume of debris coverage, with debris originating from up to 2000 ft and coming to rest in within the valley floor at Fond St Jacques to depths of up to 4 m. This debris slide originated within the steep northwestern flanks of the Migny River Valley and its tributaries, traversing a path of approximately 1.3 km. Many homes within the valley floor were partially buried and some were removed from their foundations including a Bailey Bridge structure across the Migny River at Fond St Jacques.

The surrounding peaks of the upper area of the town of Fond St Jacques, founded at the foothills, is currently under meters of earth debris from flow slides that initiated from its northern and eastern valley slopes. These slopes are extremely steep and have been designated as areas of high risk by both landslide and flow slide risk maps. The roadway toward Migny appears to give access to the higher elevations where crop cultivation goes up to the ridge line and over it. Much of the natural forest cover on these slopes has been removed and, in many cases, large tracts of land appear untended and bare. The two major flow-slides appear to originate in cleared and cultivated upper slopes.

The soils in this area appear to be deeply weathered pyroclastics over a basaltic/basement rock, where surface soil texture is mainly sand silts with clays at the lower reaches of the valley.

Flow slides from the southward facing flanks of the valley slopes at Ravine Claire were also responsible for destroying a bridge and the main arterial roadway.

**(h) Area 6 Cresslands, Soufriere**

The Cresslands development represents a relative new housing development in the lower reaches of the Soufriere Valley. Located within the immediate foothills of a southward facing flank of a northern watershed ridge, this development sits almost exactly in the path of a seasonal watercourse coming from the ridge's edge. It is along this local topographic invert feature (seasonal watercourse) that the flow slide developed and engulfed the development area with debris soils and silt laden waters. The force and pressure of the flow lifted the asphalt pavement in some areas and knocked building foundations out of plumb.

This slide appears to have initiated in virgin forest soils but within a well defined seasonal watercourse.

**(i) Area 7 Colombette**

The Colombette debris and flow slide occurred on a westward facing flank of Mount Tabac that rises from road level elevation 425 m to elevation 671 m (2200 ft) at an angle of approximately 48° and 244 m above road level. The uphill length of the slide area is therefore over 350 m long and continues downslope to a greater distance, removing the roadway structure within its path. It appears that this slide initiated within the upper slope. This type of mass movement can best be described as a debris avalanche, where the moving mass clears everything in its path on its way down slope.

Landslide mitigation in areas of this type is exceedingly difficult and might be limited to preserving forest cover and/or planting trees on the slope with deep rooting systems, such as the local mango tree.

Two persons are thought to have perished in this slide as they were not accounted for after the slide.

The soil type in this area is similar to that in the Fond St Jacques area, comprising deeply weathered pyroclastics and lightly cemented ash soils.

### **3. SAINT LUCIA HAZARD ASSESSMENTS AND MAPPING**

Over the last 25 years, Saint Lucia has invested in several natural hazard assessments, particularly in the area of landslides. Some of these outputs are as follows:

- (a) De Graff, 1985. *Landslide Inventory Map of St Lucia*. OAS 1997.
- (b) Rogers, 1997. *Landslide Hazard Data for Watershed Management and Development Planning, St Lucia, West Indies*.
- (c) CDERA 2003. *Status of Hazard Maps, Vulnerability Assessments and Digital Maps in the Caribbean, St Lucia Country Report*, J. Opadeyi, S. Ali and E. Chin
- (d) CDERA 2006. *Development of Landslide Hazard Maps for St Lucia and Grenada*; J. Euwema, P. de Jong and S. Wharton.
- (e) Government of Saint Lucia 2006. *Natural Hazard Mitigation Plan, NEMO*.
- (f) Government of Saint Lucia 2006. *Water Management Plan for Drought Conditions, WASCO October 2006*. <http://www.drmonline.net/drmlibrary/droughtsaintlucia/index.htm>
- (g) Government of Saint Lucia 2010. *Vulnerability Assessment Second National Communication*; E. Soomer and D. Alphonse (Maps based on mapping by De Graff, Rogers, 1992, 1995). Sustainable Development & Environment, Ministry of Physical Development & Environment.

Upon observing the damage that Hurricane Tomas inflicted on the environment and reviewing the status of hazard mapping as pertains to landslides, the report expressed by the authors of the report entitled “Status of Hazard Maps Vulnerability Assessments and Digital Maps”, Saint Lucia Country Report, CDERA 2003:

*“Overall, it appears that the hazard maps available in the country are not as widely circulated as they should be. There is also need for more updated maps at a larger scale and the inclusion of other hazards such as flooding. Hazard maps may be more useful if the scale of preparation is at the local or community level, rather than the national level.”* CDERA 2003.

The rainfall component of Tomas was an extreme event, hence its damage capacity could not have been accounted for in hazard mapping that is typically based on historically derived data and empirical correlations.

These hazard maps do not utilize algorithms that could model infiltration, pore-pressures changes and stability analyses in a quantitative manner consistent with a specific event magnitude obtained from probabilistic and/or deterministic analyses of storm intensity. So it is laudable to note that these maps correctly identified three areas of high landslide and flow slide Risk in which Tomas-induced slides have occurred: Barre de L’Isle, Fond St Jacques and Colombette (these areas are very steep and have had historical events). However, in areas where significant slippage has occurred on moderate to shallow slopes (seven houses buried and sections of roadways breached), the hazard maps indicate moderate to low risk; Bagatelle, Guesneau, Trois Pitons and Bocage.

In this latter case, it is apparent that the soil type, geology and rainfall parameters do not tell the complete picture of landslide susceptibility. Reasons that can be attributed to the demonstrated limitations of hazard mapping, in this case, could be attributed to:

- (a) The soil maps available over the Caribbean subregion were developed in the 1950s – 1960s for agricultural purposes/crop production and, hence, their descriptions are typically based on samples taken within 1-1.5 m of the ground surface. As a consequence, their descriptors give limited insight into the engineering/quantitative aspects, of internal soil strength and hydro-geologic characteristics to the depths of typical failure zones; 2-6 m deep.
- (b) Geological maps tend to have the opposite problem in that their descriptors typically refer to parent/deep geological structure, and do not necessarily include near surface features such as degree and nature of fractures (macro-porosity), bedding orientation, basement rock depth, etc.
- (c) The hazard maps do not include the effects of vegetative cover, previous or current land use (naturally deforested area, by bushfires, previously cultivated, cleared/grubbed for proposed development).
- (d) The hazard maps do not include hydro-geological conditions, artesian water potential (spring development), groundwater conditions and type.

Although not specifically quantified as a hazard in previous hazard reports, drought susceptibility has been the subject of a project of the Government of Saint Lucia, Second Disaster Management Project "Development of Drought Hazard Maps for Saint Lucia", 2007.

Projects of this nature can be used to develop integrated approaches to soil-climate risk modelling or forecasting based on probabilistic or deterministic methods.



**House felled by landslide, The Morne, Castries**



**The Bexon Valley, a sea of mud**



**Bexon Valley, braving the flood waters**



**Multiple landslides, Marc**



**Living in the landslides, Marc**



**Landslide in cultivated slope**



**Baree de L'Isle Ridge**



**Barre de L'Isle, other side of ridge (road behind)**





**Thomazo, edge failures in roadway, surface runoff related slips**



**Thomazo, roadway lane failure with boulder pack repair**



**Thomazo, roadway lane failure with boulder pack repair**



**Roseau Dam looking south**



**Roseau Dam, minor spillway damage, east abutment**



**Generator landslip west abutment**







**Roseau Dam, multiple debris flows in catchment area**



**Microwave tower foundation breach by landslide**



**Agricultural access road Migny to microwave tower-I**





**Agricultural access road Migny to microwave tower-II**



**Top: Path of main flow slide along eastern Migny River tributary.  
Bottom: Looking west toward Soufriere, Migny village left, flow slide from right**



**Fond St Jacques: Flow slide burying roadway and dislodging bridge**



**Top: Cresslands Development, looking toward Soufriere,  
Bottom: Looking down the path of flow slide toward the development**



**Colombette-I**



**Colombette-II**



**Trois Pitons landslide**



**Guesneau: 150 m of Roadway in front of yellow house breached by landslide-I**



**Guesneau: 150 m of roadway in front of yellow house breached by landslide-II**





**Bagatelle – I**



**Bagatelle – II**

## II. THE AFFECTED POPULATION

Hurricane Tomas left a path of destruction in its wake on the north western and south western side of the island. Communities in Castries rural such as Guesneau-Forestiere and Fond Canie, Bexon and Marc; and in the District of Soufriere, communities such as Fond St. Jacques and the sub settlements of Ravine Claire, Cresslands, St. Phillip and Migny were especially hard hit. See map 3 for the location of communities in which families were affected due to destruction of homes and loss suffered as a result of severe flooding.

Map 3: Location of houses destroyed by Hurricane Tomas

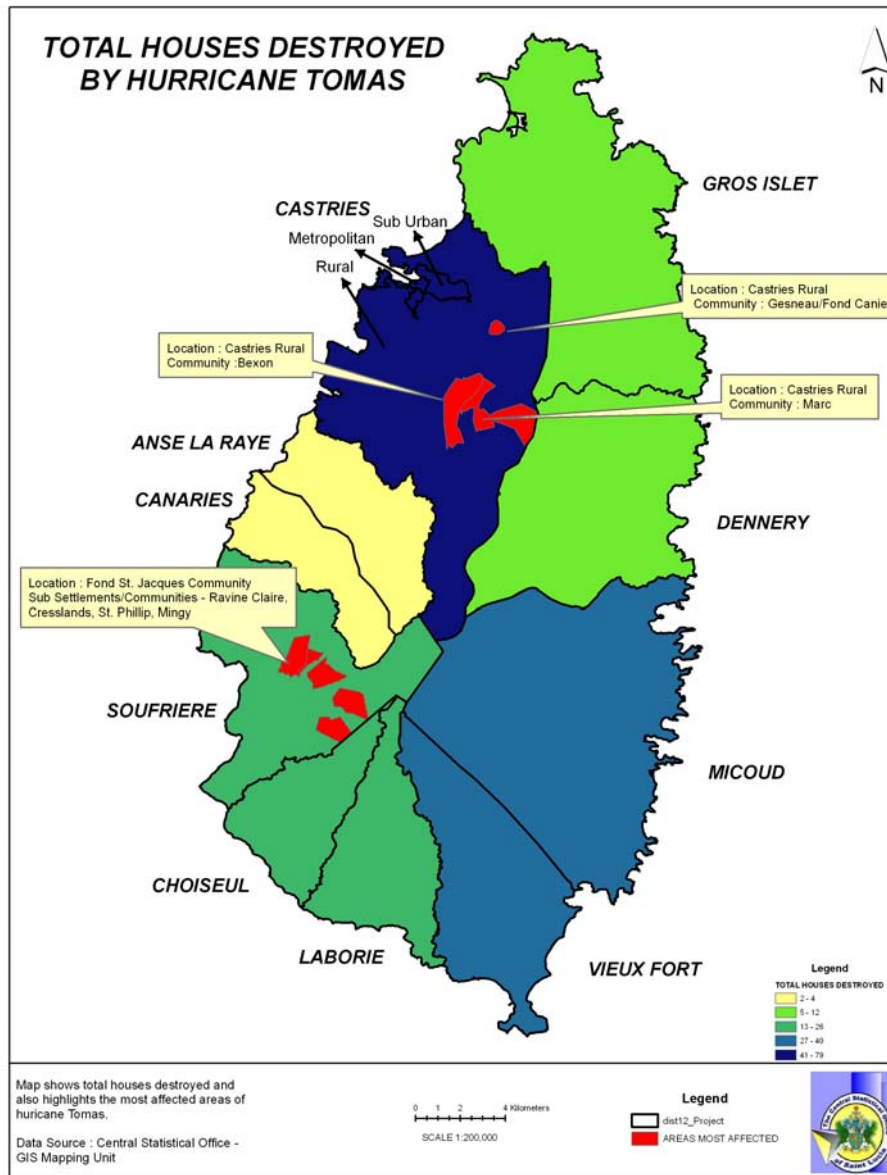

Source: Compiled by the Central Statistical Office based on ECLAC estimates of Government of Saint Lucia data

### A. THE GEOGRAPHIC SPREAD OF THE AFFECTED POPULATION

Table 2 presents the details of the affected population by District. The data as collected by NEMO, the Red Cross and the Ministry of Housing, suggest that some 5,952 persons, or 3.5% of the national population were severely affected as a result of Hurricane Tomas. The majority of the affected population, some 28% or 1,709, could be found in the district of Castries in the suburban/rural area which, when combined, has the largest population of all the districts in Saint Lucia and a significantly high proportion of persons classified as vulnerable (16.8%). Another 16.6% or 986 of those severely affected could be found in Soufriere which has the highest proportion of Saint Lucians defined as poor but not indigent (42%), and 15.3% or 909 of those affected could be found in Micoud which has a significant proportion of persons defined as vulnerable (13%).

**Table 2: Severely affected population by district**

Geographic District	Male	female	Total population	Severely Affected Population	Population without pipe borne Water for two week period
Whole Country	84465	87905	172370	5952	137,896
Castries metro	928	1045	1973	...	1,578
Castries suburban/rural	33589	35034	68623	1709	54,898
Anse La Raye	3385	3257	6642	275	5,314
Canaries	1016	1003	2019	77	1,615
Soufriere	4101	4082	8183	986	6,546
Choisuel	3146	3332	6478	294	5,182
Laborie	3873	3943	7816	371	6,253
Vieu-Fort	8455	8642	17097	554	13,678
Micoud	8443	8677	17120	909	13,696
Dennerly	6801	7044	13845	378	11,076
Gros-Ilet	10728	11846	22574	400	18,059

Source: ECLAC estimates based on data received from the Statistical office of the Government of Saint Lucia; Ministry of Housing, NEMO and Red Cross

Figure 5 illustrates the distribution of the affected population by district and by the levels of vulnerability in each district. Although the data does not indicate a direct corollary among districts which possessed the most vulnerable populations and those that were most affected by the impact of Hurricane Tomas, it however suggests that where communities are already vulnerable and are exposed to hazards and extreme events, as in the Castries rural areas and the communities of Soufriere, pockets of devastation can occur, as was evident.

**Figure 5: Distribution of Affected Population and level of Vulnerability**

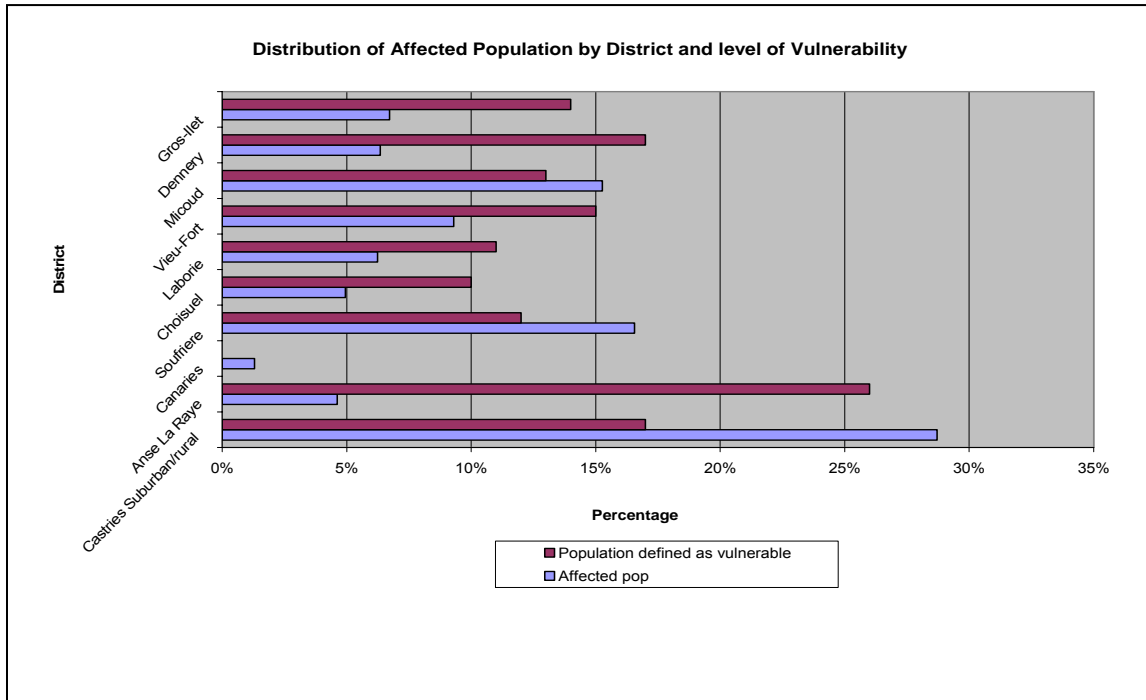

Source: ECLAC estimates based on official Government of Saint Lucia data and vulnerability data drawn from the Poverty Assessment of 2005/06

NEMO reported that district committees activated emergency shelters as early as 30 October and at its peak on 11 November, they reported some 473 persons had taken refuge due to the conditions in their own home. The largest group of persons in shelter was found in the District of Soufriere, from the Community of Fond St. Jacques. Many stayed away from their homes due to fear posed by the risk of continuing land slides. Figure 6 illustrates the numbers of persons in shelter over the period of review.

**Figure 6: Persons in shelter**

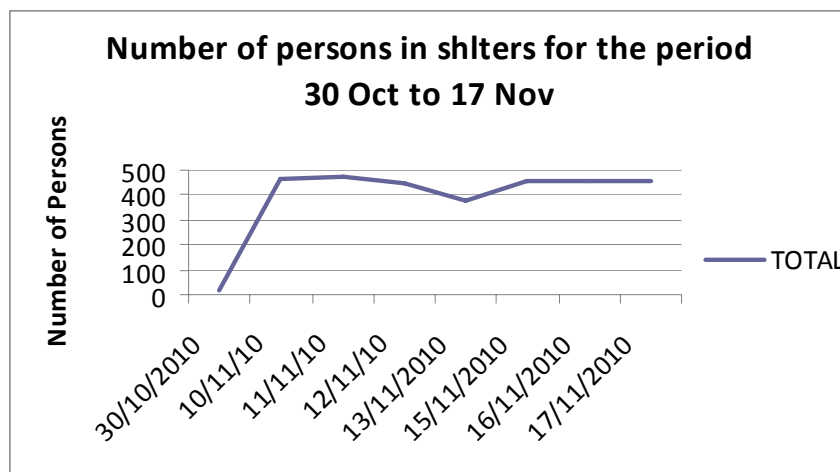

Source: ECLAC estimates based on NEMO data

## B. THE HEALTH STATUS

Reports from the Ministry of Health indicate that seven persons were reported to have lost their lives, five are reported as missing and 36 suffered a variety of physical injuries as a result of Hurricane Tomas. Figure 7 presents the distribution of injuries treated by the Ministry of health during the period. It is a credit to the dedication of the health care professionals in the Ministry of Health and to the health status of the population of Saint Lucia that no major illnesses or epidemics emerged following the passage of Hurricane Tomas.

Figure 7: Injuries suffered

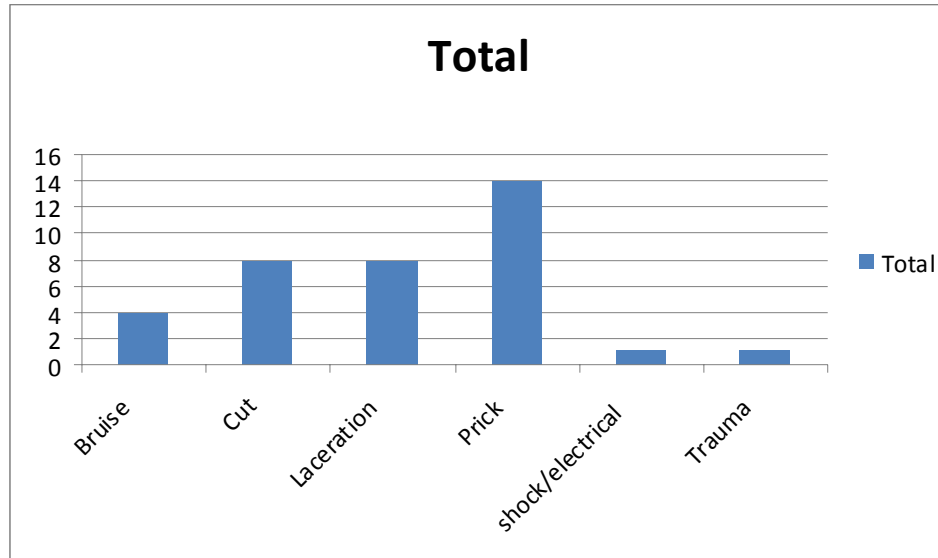

Source: ECLAC estimates based on Ministry of Health data

The Ministry of Health noted in its report that the current human resource capacity in the primary health care service is inadequate to meet health care needs post-Tomas. It concludes that while persons of higher income may be able to seek health care in the private sector, lower income families' needs may have to be postponed or go unmet because of the difficulty of access to health facilities created by Hurricane Tomas. In addition, the report noted that Saint Lucians were without pipe borne water for approximately two weeks and many were forced to seek water from rivers, streams and other sources. The supply of bottled water on the island was quickly depleted as persons with greater purchasing power were able to buy water in greater quantities, while those of lower economic status sought alternative water sources sooner than their better off counterparts.

The ministry also reported that it observed that there was an increase in the numbers of cases of the gastroenteritis and undifferentiated fever in weeks 41-42 of 2010 compared to the same period in 2009, as detailed in table 3. The gastroenteritis and undifferentiated fever, he ministry reported were placed in the epidemic area of endemic level.

The Ministry noted that the social and psychological dimensions and needs of the persons affected had not been fully estimated. It was suggested that the Ministry did not have the facilities nor capacities to meet all the many psychological needs of those who were displaced and particularly children who experienced the ravages of the storm.

**Table 3: No of reported cases by Syndromes, weeks 41-42 2009-2010**

Syndrome	Weeks 41 - 42	Weeks 41 - 42
	2009	2010
Gastroenteritis <5 Yrs	29	44
Gastroenteritis >5 Yrs	27	67
Undiff Fever <5 Yrs	44	68
Undiff Fever >5 Yrs	100	124
ARI <5	265	72
Fever and Respiratory Symptoms	1027	107
<b>Total</b>	<b>1492</b>	<b>482</b>

Source: ECLAC estimates based on Ministry of Health data

The ministry anticipated a light increase in gastroenteritis in the following weeks particularly when school reopened, and sought to counter such with an increased public education campaign.

### C. THE LEVEL OF IMPACT ON THE POPULATION

Figure 8 presents an illustration of the distribution of the affected population according to the extent of the impact of Hurricane Tomas.

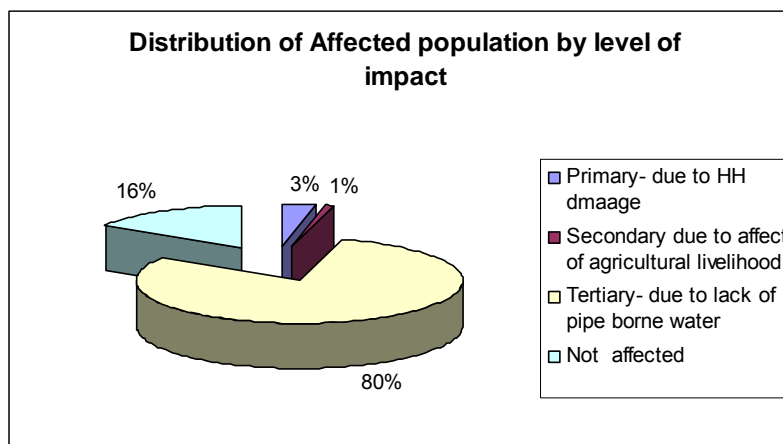
**Figure 8: Distribution of affected population by level of impact**

Source: ECLAC estimates based on official data

Four groups of the population were identified: the primary, the secondary, the tertiary and those not affected. The primary group comprising 3% of the total population or 5,952 persons, represent those who have been affected due to the damage and destruction caused to their homes by Hurricane Tomas. The secondary group, of 1% or 1330 farmers, represents those who have been affected because their livelihood, particularly production of banana, which has been severely affected by the devastation suffered to their crops and land used for cultivation. This proportion may be underestimated as all data for other agricultural producers have not yet come to hand. The tertiary group, of 80% or 137,896, represents the proportion of the population who were without potable water for a period of roughly two weeks

following the event. The last group of 16% represented those who would not have been directly affected by the event. It can be concluded from this analysis that although a small proportion of the population was severely affected by Hurricane Tomas, it had a widespread secondary effect of restricting persons' access to potable water over a significant period of time. It is a credit to the resilience of the Saint Lucian population and its health sector that no major outbreak of water borne diseases occurred. However, data from the Ministry of Health suggests that there was a 47% increase in under-5 gastroenteritis for 2010, over the 2009 figures, and much of this may be attributable to the effects of the water situation caused by Hurricane Tomas.

#### D. THE DIFFERING VULNERABILITY OF WOMEN AND MEN

The Poverty Assessment Report of 2005/2006 found that overall 28.8% of Saint Lucians could be categorized as poor. This represented a 13% increase over the proportion of the population that had been defined as poor in 1995, although there was a marked decrease in the proportion defined as indigent. Table 4 presents key findings of the study in this regard.

**Table 4: Saint Lucia: Indigence, Poverty and Inequality 1995 and 2005/2006**

Indicators (%)	1995	2005/2006
Poor Households	18.7	21.4
Poor Population	25.1	28.8
Indigent households	5.3	1.2
Indigent Population	7.1	1.6
<b>Gini Coefficient: inequality measure</b>		
At value all individuals have equal wealth	0.5	0.42

Source: Saint Lucia Country Poverty Assessment 2005-2006  
Volume 1 Main Report

In regard to vulnerability, the report noted that a vulnerability line was estimated at EC\$6,357.50 per annum, concluding that 40.3% of the population was estimated to be consuming at levels below this line, thus vulnerable. Among the indicators which the assessors had selected for inclusion in the social vulnerability of the population, was that of poor housing and female headship of households. The report found that significantly, 33.3% of households experienced poor quality housing or substandard housing conditions. Such a finding, suggests that if the event had been more severe, the consequences suffered by the population might have been harsher.

The report observed that when weak social capital is taken into account and is combined with significantly high proportions of female headship, substandard housing and location of homes in disaster prone areas, a clear picture of vulnerability can be drawn.

Female headship in Saint Lucia has a national average of 44% and a higher still proportion among the low/middle income households, 47%, as indicated in table 3. Such a high proportion of female headed households, would suggest that the attributes of female headship such as low levels of employment of women, women's location in the labour market in low wage segments; and larger than average household sizes would be quite pervasive in Saint Lucia. The report concludes that these attributes when combined with the other attributes of social vulnerability could lead to a situation in which certain households, particularly those that are female headed who may not be poor, could find themselves instantly pushed below the poverty line in the event of an economic shock or of a natural

disaster. The events of Hurricane Tomas are precisely the situation of which the report warns and may result in large segments of female-headed households being pushed below the poverty line.

**Table 5: Demographic and social characteristics of the population**

	<b>Total Population</b>	<b>% of Household heads</b>	<b>% of Household heads in low/middle income HHs</b>	<b>% of Unemployed by sex</b>	<b>Primary School as the Highest Level of education attained by Poor Heads of HH</b>
Females	87905	43.6%	46.5%	12.5%	66%
Males	84465	56.4%	53.4%	4.2%	80%

Source: ECLAC estimates based on official Government of Saint Lucia data

The implications for such an occurrence could have far reaching effects on the well-being of the women heads of households, their children, and the adolescents and elderly who fall within their care.

As part of the macro socio-economic and environmental assessment of the impact of Hurricane Tomas, a series of focus groups were undertaken to ascertain differential perceptions of the impact of Hurricane Tomas on men and women in a selected number of affected communities. A brief analysis suggests that women expressed a fear of greater dependency on fathers, partners, husbands, brothers or boyfriends in order to meet their basic needs as they expressed the view that it was going to be very difficult for them to be able to earn an income or meet their family's food needs by subsistence farming. Past experience with survivors of disasters suggest that such situations can put women at risk to the mounting pressures for participation in transactional sex with poor social and health consequences.

Men, on the other hand, feared that they would not be able to farm as they had seen their land washed away, or had no access to farm lands because of blocked roads and damaged forest trails.

Many women bewailed the loss of crops and the loss of land through land slippage, others lost their shops and the goods in them. One woman, from Fond St, Jacques, expressed her despair, "if you have children and you don't even have a green fig to give them, what can you do?" Another from Marc in seeking to explain the way in which the Hurricane had destroyed her ability to maintain her sense of dignity and independence and to assist others in time of need said, "now everyone needs a pound of rice".

Men expressed the hope that there would be some work to clean up the place so that they could still make a living. Others indicated that they spent their time "looking for food and other things for family". In Fond St. Jacques, which had been badly damaged, many farmers expressed the view that they did not wish to be moved. One farmer said it this way, "the majority of us will not leave because we from here, born here, not leaving".



### III. DESCRIPTION OF DAMAGE AND LOSSES BY SECTOR

#### A. INFRASTRUCTURE

The infrastructural elements that have been examined under this Damage and Loss Assessment include: the water supply sector, roads and bridges, rivers, electricity, telecommunications, and airports/seaports.

##### 1. WATER AND SEWERAGE

###### (a) Description of damage

The information from several executives of the WASCO served to provide a good overview of the state of the utility, its associated infrastructure and the damages that had been sustained as a result of the hurricane.<sup>14</sup>

In general, the billing of accounts by WASCO is done on a category basis, which gives insight into the customer base for this utility. Categories include: boats; commercial users; domestic users; government offices and agencies; and hotels. In total, there are 55,487 water supply accounts and 3,762 sewerage accounts. The breakdown by category is displayed in the following diagram, with boats attributing 0.1% and hotels 0.2%, respectively (these are both shown as 0% in figure 9).

Figure 9: Distribution of WASCO accounts

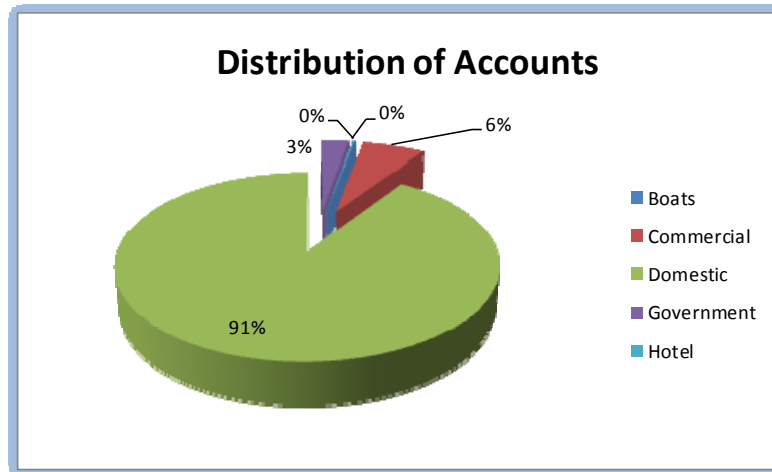

Source: WASCO's data

Some of the important findings and conclusions that emerged from the referenced meeting are summarized as follows:

- (a) In general, this utility has fairly old infrastructure and hence most of this infrastructure is already compromised in terms of efficiency and effectiveness.

<sup>14</sup> A meeting was held with Mr. John Josephs – Managing Director and Mr. Traverne Yorke – Water Services Manager, WASCO on 18 November 2010.

(b) Almost every single intake structure and associated equipment was damaged and silted up as a result of the hurricane rains.

(c) In the north, the John Compton (Roseau) Dam was damaged (photo 1a). This damage included:

- (i) The access road to the dam was washed away.
- (ii) The mountains surrounding the dam suffered severe slope failure, leading to extensive sedimentation of the dam and consequent reduction of its containment capacity.
- (iii) Sections of the dam spillway were damaged as a result of slope failure of adjacent earth embankments.



**Photo 1a: Damage to spillway**



**Photo 1b: Damage to access road**

(d) Water was not distributed from this facility for approximately two weeks after the event, which created significant hardship for a majority of the society given the fact that the dam serves approximately 80% of the population of Saint Lucia.

- (e) The gravity intake on the Millet catchment, which augments the Roseau Dam, was damaged. Pipes were damaged either from being washed out or from landslides.
- (f) The section of pipeline from Junction Tank to Vanard (11.2 km) had always apparently presented a problem, in that the pipes had never been welded together, but rather were held together with couplings. The pipeline encountered significant problems during the hurricane, as joints became dislodged as a result of earth movements, river erosion, etc. It should be noted that this section of pipeline represents one of the most serious threats and vulnerabilities to the supply of water to the north (80% of the population) and consequently, to the primary tourism economic base of the island.
- (g) Of the five gravity lines that feed the Hill 20 Treatment Plant in Babonneau, three were washed away.
- (h) 4.8 kilometres of 200mm dia. pipeline from Anse La Raye were lost.
- (i) At Canaries, an intake was lost, as well as raw water and treated water transmission lines.
- (j) At Soufriere, intakes were silted, however, these have now been restored to working order.
- (k) At Vieux Fort, a number of problems have surfaced that WASCO has not been able to deal with. Specifically, these include, *inter alia*:
- (i) A large section of the island's industrial plant is in this area, therefore, a reliable water supply is essential.
  - (ii) The 7-year old membrane filter unit does not work satisfactorily, so the present water supply system only uses chlorination as a treatment method to water collected in a tank. This is not considered to be a sustainable method of water treatment.
  - (iii) A proper "fix" for this system will require significant capital expenditure.
- (l) Immediately after the hurricane, NEMO was tasked with the trucking of water to essential services.

For the areas in the north, and for the first week after the event, no water was distributed. Within the first 48 hours of the second week, 1.2 mgpd<sup>15</sup> were distributed. By the end of that second week, WASCO was distributing 3.5 mgpd. At the start of the third week, the distribution had risen to 7.8 mgpd, eventually falling back to 7.1 mgpd by the end of that week. It should be noted that the usual supply volume from this source is approximately 9 mgpd.

For the rural systems network, such as Canaries, Micoud and Desruisseaux, systems were expected to be back up within one to two weeks after the event. The outstanding problem in these areas was in Vieux Fort, where the impact of the hurricane had exacerbated an existing problem, leading to a situation whereby the post-hurricane delivery volume of treated water was below that which previously existed.

---

<sup>15</sup> Million gallons per day (mgpd)

Table 6, developed from information provided by WASCO, gives a detailed summary of the extent of damages experienced and the areas where these occurred.

Table 6: Description of damage to WASCO equipment and plant

No.	Production facility/Intake	Location	Damages Incurred	
1	Marquis Intake	Marquis	Access to intake blocked by landslide material; intake blocked with sediment from river; power lines damaged	
2	Talvern Intake	Talvern	Intake blocked by river sediment	
3	Hill 20 La Sorciere Intake	#1	Chassin	Intake blocked by river sediment; transmission line broken
		#2		Intake blocked by river sediment; transmission line broken
4	Joseph intake	Babonneau	Intake totally destroyed	
5	Piton Intake	Babonneau	Intake totally destroyed	
6	Louisy Intake	Babonneau	Intake totally destroyed	
7	Forestiere Intake	Foriestiere	Pump damaged	
8	Des Barras	Babonneau	Intake blocked by river sediment; transmission line broken	
9	Des Rameaux	Babonneau	Intake blocked by river sediment; transmission line broken	
10	Roseau Dam	Millet	Pumps damaged; electrical lines down; access roads blocked; spillway damaged; pump controls and housing damaged; transmission line damaged; sedimentation of water within the dam; water polluted with organic matter	
11	Ciceron Millet Intake	Millet	Access to intake blocked by landslide material; intake blocked with sediment from river; 24" ductile iron transmission line damaged in several locations	
12	Vanard Intake	Varnard	Access to intake blocked by landslide material; intake blocked with sediment from river; 24" ductile iron transmission line damaged in several locations; power lines damaged	
13	Ravine poisson Intake	Ravine Poisson	Access to intake blocked by landslide material; intake blocked with sediment from river; 24" ductile iron transmission line damaged in several locations; power lines damaged	
14	Anse La Raye Intake	Venus Estate, Anse la Raye	Access to intake blocked by landslide material; intake blocked with sediment from river; power lines damaged	
15	Anse La Verdue Intake	Anse La Verdue	Access to intake blocked by landslide material; intake blocked with sediment from river; transmission line broken	
16	Canaries Intake	Canaries	Access to intake blocked by landslide material; intake totally covered with river sediment; power lines damaged; housing to the slow sand filter damaged	
17	Thomazo Intake	Dennerly	Access road to intake blocked by dislodged material; intake blocked by river sediment; transmission and distribution lines damaged in a number of locations	
18	Au Leon Intake	Au Leon	Access road to intake blocked by dislodged material; intake blocked by river sediment; transmission and distribution lines damaged in a number of locations	
19	Dennerly	Errard #2 (new)	Dennerly	Access road to intake blocked by dislodged material; intake blocked by river sediment; transmission line damaged in a number of locations
20		Errard #1 (old)	Dennerly	Access road to intake blocked by dislodged material; intake blocked by river sediment; transmission line damaged in a number of locations
21	Derniere Riviere	Derniere Riviere	Access road to intake blocked by dislodged material; intake blocked by river sediment; transmission line damaged in a number of locations	
22	Patience Intake	Lumbard	Access road to intake blocked by dislodged material; intake blocked by river sediment; transmission line damaged in a number of locations	
23	Micoud	Mahaut	Access road to intake blocked by dislodged material; intake blocked by river sediment; transmission line damaged in a number of locations	
24	Deruisseaux		Access road to intake blocked by material dislodged during storm; intake totally destroyed; transmission line damaged in a number of locations	
25	Belle Vue		Access road to intake blocked by dislodged material; intake blocked by river sediment; transmission line damaged in a number of locations	
26	grace woodlands		Access road to intake blocked by dislodged material; intake blocked by river sediment; transmission line damaged in a number of locations	
27	Beausejour		Access road to intake blocked by dislodged material; intake blocked by river sediment	
28	saltibus lower		Access road to intake blocked by dislodged material; intake blocked by river sediment; transmission line damaged in a number of locations	
29	saltibus upper		Access road to intake blocked by dislodged material; intake blocked by river sediment; transmission line damaged in a number of locations	
30	Choiseul Toucousson	Choiseul	Access road to intake blocked by dislodged material; intake blocked by river sediment; transmission line damaged in a number of locations	
31	Delcer Intake	Delcer	Access road to intake blocked by dislodged material; intake blocked by river sediment; transmission line damaged in a number of locations	
32	Ruby Intake River source, Spring source	Soufriere	Access road to intake blocked by dislodged material; intake blocked by river sediment; transmission line damaged in a number of locations	
33	Soufriere Diamond Intake 1 and 2	Soufriere	Damage to transmission line	
34	Fond St Jacques (lower)	Fond St Jacques, Soufriere	Access road to intake blocked by Fond St Jacques landslide (site unstable)	
35	Fond St Jacques (upper)	Fond St Jacques, Soufriere	Intake completely destroyed (site unstable)	
36	Migny (river)	Fond St Jacques, Soufriere	Intake completely destroyed (site unstable)	
37	Bouton	Castries/ Soufriere Highway	Access road to intake blocked by dislodged material; transmission line damaged in a number of locations	
<p>North</p> <p>South</p>				

Source: ECLAC estimates base on WASCO's data

**(b) Estimate of damage and losses**

An estimate of damage and losses was made for this utility, based on the internal damage evaluations developed by WASCO, and on the loss of business estimates provided by WASCO and also estimated separately based on the known customer base, the user rates and in conjunction with the down-time experienced.

The estimates gave the following:

- The total estimated damages were EC\$53,016,600
- The total estimated losses were EC\$66,452,853

**(c) Comments and recommendations for improvements**

Based on the interviews conducted and observations made, the following are offered as suggestions that are intended to reduce the vulnerability of this utility to natural hazards:

- (a) The section of pipeline from Junction Tank to Vanard in the north represents a potential weak link in the sustainability of water supply to the largest customer base in Saint Lucia (80%). As a result, it is recommended that either some measure of redundancy be built into this system, through the installation of a second pipeline, or the problems that have plagued this section of line be resolved in a proper and comprehensive manner at the earliest possible opportunity.
- (b) The water treatment and distribution system in the south, specifically for Vieux Fort, needs to be revamped and updated as required.
- (c) A bathymetric survey of the Roseau Dam should be commissioned immediately, to quantify the levels of sedimentation that have occurred in the dam as a result of Hurricane Tomas.
- (d) Following the quantification of sedimentation volumes, a suction dredge should be employed to remove the sediment from the dam. This dredged material should then be stockpiled in a location that will not create further geotechnical instabilities.
- (e) Some measures of slope stability need to be employed on the slopes of the mountains that surround the dam.

**2. ELECTRICITY GENERATION (LUCELEC)****(a) Description of damage**

LUCELEC's infrastructure experienced the impact of Hurricane Tomas from around 5pm on 30 October 2010, when the system became unstable. As a result, management decided to shut down power across the island. The following morning by 7am, the process of carrying out initial assessments began, resulting in the restarting of the system from approximately 3pm on the Sunday 31 October.



**Photo 2: Damaged electrical infrastructure**

Start up in this case followed a previously developed and agreed upon “Priority Restoration Model”, which requires the restoration of power first to hospitals and emergency services, then to the Castries area (Castries sub-station), then to Reduit. Union was left off-line since, at that time, it was under approximately 1 metre of water. It was subsequently brought back on-line in a week. Similarly, the Soufriere substation was not brought back up immediately.

By 5 November 2010, 90% of the customer base had been brought back into service. Restoration efforts were aided by the diversion of a barge from Barbados to Soufriere, which was used to get the system there back into service. Within two-and-a-half weeks after the event, only Fond St. Jacques remained without power, however, it should be noted that the residents of this community were evacuated following the storm. In addition, some transmission work was still ongoing at that time in Columbette. It was estimated that work would have been finished by 20 November 2010.<sup>16</sup>

Also of note is the fact that LUCELEC gave assistance to WASCO in restoring power to the control systems at the Roseau Dam. This resulted in normal levels of electricity being restored to the dam and control mechanisms within a very short period of time. Damage to the electrical plant at the dam that had to be attended to by LUCELEC included:

- (a) Inundation (due to water) at the substation
- (b) Erosion of river banks, leading to damage to poles and other related infrastructure
- (c) Landslides, leading to damage to electricity generating equipment.

Map 4 shows the distribution network used by LUCELEC, with the location of the main generating power station at Cul-de-Sac and the various substations. It is of interest to note that approximately 75% of the utility’s customer base is served by the north ring.

---

<sup>16</sup> The overview descriptions of damages and losses experienced by LUCELEC were facilitated through an interview with Mr. Trevor Louisy, Managing Director and Mr. Earl Estrado, Financial Controller on 19 November 2010.

Map 4: LUCELECA line distribution network

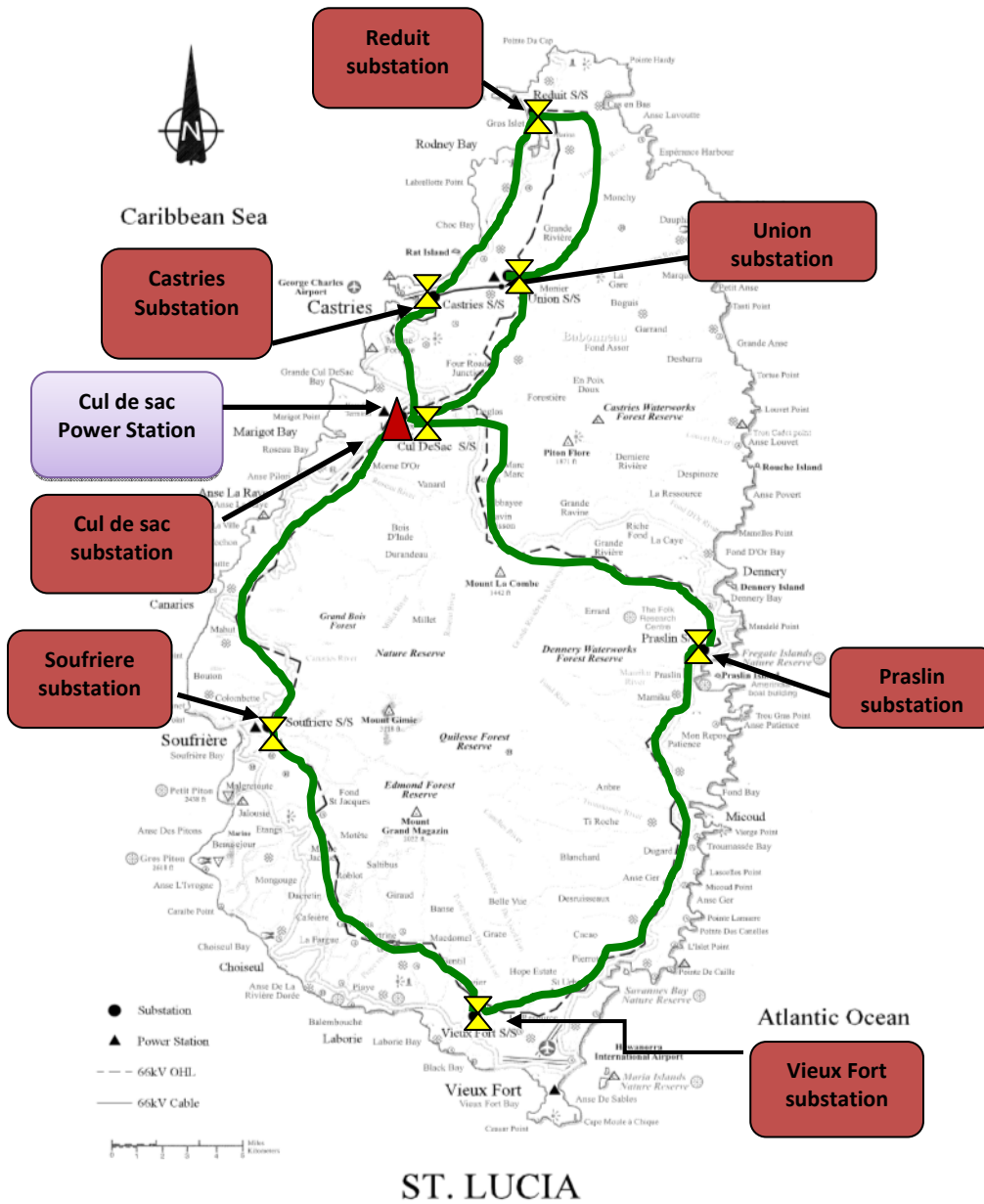

### (b) Estimate of damage and losses

An estimate of damages and losses was made for this utility, based on the internal damage evaluations that were provided by LUCELEC. Loss of business estimates were developed based on the shut down and restarting schedules described in the meeting with the management team, and applying this data to the known customer base.

The estimates for this utility were:

- The total estimated damages were EC\$3,500,000
- The total estimated losses were EC\$4,839,726



**(c) Comments and recommendations for improvements**

In general, it was clear that LUCELEC had put measures in place to ensure that it remained well insulated from the effects of events such as this. Damage and losses were low for this utility as compared with previous events and in comparison to WASCO.

Recommendations made by the Managing Director in relation to queries relating to the reduction of vulnerability from future events included, *inter alia*:

- (a) Relocation of the Union Substation to a location beside its existing position, on slightly higher land. Experience from Tropical Storm Debby in 1994 showed that this station was vulnerable to flooding.
- (b) Elevation of the critical infrastructure in the relocated Union Substation by approximately 1 metre above floor level.

It is estimated that this relocation could cost of the order of EC\$2.8 million.

It is also recommended that, if not presently so, NEMO should include representation by LUCELEC in its list of first responders after a natural hazard event.

### **3. TELECOMMUNICATIONS**

**(a) Digicel**

In general, damages experienced by Digicel were minimal. Five light towers were damaged in three locations. The towers included three fixed unit cell towers and two cell-on-wheels and damage to all units was occasioned by wind. In addition to the tower damage, there were damages to some of the retail stores in Castries.

With respect to losses incurred, there were operational costs involved in getting the network up and running after the hurricane. To a large extent, those costs related to transportation of personnel around the island. Of all the locations on an island-wide basis, Soufriere was down for the longest period, with services being out for four days.

As a measure of goodwill, Digicel gave out US\$400,000 worth of credit generally to its customer base, and another (approximately) US\$30,000 in phones and credit to essential services such as: NEMO, the Police, LUCELEC, WASCO, Ministry of Works, the Red Cross, etc. In addition and as part of an overall relief policy, Digicel gave food, water, clothing, generators and free handsets to its customer base.<sup>17</sup>

It should be noted that the Digicel management team expected some ongoing long-term losses resulting from the negative effect on the economy as a consequence of the hurricane. These longer-term losses have not been accounted for in this assessment.

**(b) Lime**

No representatives from Lime were available for meetings during the team visit and representatives from the Ministry of Finance were subsequently unable to obtain appointments with Lime management. As a

---

<sup>17</sup> A meeting was held with Mr. Keigan Cox, Director – Business Development Eastern Caribbean, and with Ms Geraldine Pitt, General Manager – OECS South at Digicel headquarters in Rodney Bay on 19 November 2010.

result of this, proxy values were used in the assessment of damages and losses for this provider, based on a review of the Digicel numbers and assuming a market share distribution between the two companies.

**(c) Radio Saint Lucia (RSL)**

An interview was held with an official of RSL. Damage to this radio station, which is fully owned by the Government of Saint Lucia included:

- Antenna damaged in Vieux Fort
- Antenna damaged in Castries
- Flooding in their main building and damage to building and roof through seepage of water through the roof.
- Damage to a transmitter

With respect to losses experienced, these related primarily to loss of income from sales of advertising slots in November and projected into December.

**(d) Estimate of damage and losses**

An estimate of damages and losses was made for the telecommunications subsector, based on the information provided by Digicel and RSL, and on the use of proxy figures to estimate the relevant damages and losses for Lime.

The estimates were:

- The total estimated damages were EC\$883,900
- The total estimated losses were EC\$9,205,715

**(e) Comments and/or recommendations for improvements**

Based on observations from recent disasters in the region, it is becoming increasingly clear that the use of cellphones can assist significantly in post-event rescue and recovery scenarios, in helping to locate individuals who may have been cut off from their communities, and in assisting ongoing communications with family, friends and the outside world during an event. This underscores the relevance of this subsector in restoration efforts.

One point that was raised by the Digicel management team was that the Government of Saint Lucia did not offer any concessions to the industry for equipment replacement. It was proposed that the granting of duty-free concessions after a disaster event be considered by the Government of Saint Lucia, to assist in the rehabilitation process.

#### **4. SEA AND AIRPORTS**

**(a) Description of damage**

Following the passage of Hurricane Tomas, both airports were closed. Within three days the George F L Charles Airport was reopened for limited access and emergency. In the south, Hewanorra opened by 3 November. Immediately after their reopening and while the main roads were still blocked, LIAT, CariCom Airways and Virgin Atlantic operated a shuttle service between the south and the north. In addition, two helicopters were used to ferry people around and for reconnaissance missions.

In discussions with personnel from Saint Lucia Sea and Airports Authority (SLASPA), it was disclosed that there was no measurable damage at any of the sea or air ports of the island. The runway at Hewanorra did, however, have to be cleared of mud after the event.

Losses for these facilities included:

- Air shuttle passenger fees between the north and the south
- Loss of passenger taxes at both airports as a result of reduced numbers of visitors arriving, and less passengers departing
- Clean up of mud from the runway at Hewanorra
- Loss of aircraft landing fees at both airports

Tables 7 and 8 show average and actual (following the storm) load factors for both Hewanorra and George F L Charles airports. A review of the data presented shows that Hewanorra was significantly affected immediately following the event (30 October to 10 November), as far fewer passengers either arrived or left during that time. The difference was not as noticeable in the north at George F L Charles.

**Table 7: Load Factors for Hewanorra Airport – Arrivals and Departures**

	Land		Depart	
	Review Period	Average	Review Period	Average
<b>Air Canada</b>	43.8	79.25	67.52	84.35
<b>American Airlines</b>	78.19	72.5	28.06	72.86
<b>British Airways</b>	18.83	41.13	51.49	42.5
<b>Delta</b>	47.15	79.16	43.92	82.36
<b>Virgin Atlantic</b>	5.23	74.89	66.08	76.4
<b>West Jet</b>	33.19	74.29	53.4	79.92
<b>Jet Blue</b>	39.83	79.26	48.67	79.1
<b>Condor</b>	52.5	54.48	35	58.51
<b>US Airways</b>	0	71.85	0	75.28
<b>Total</b>	<b>27.87</b>	<b>69.07</b>	<b>53.46</b>	<b>70.77</b>

Source: ECLAC estimates based on SLASPA data

**Table 8: Factors for George F L Charles Airport – Arrivals and Departures**

	Land		Depart	
	Review Period	Average	Review Period	Average
<b>Air Caraibes</b>	18.69	41.98	45.48	45.95
<b>American Eagle</b>	25.32	58.9	65.73	67.51
<b>LIAT</b>	24.44	33.47	44.27	37.75
<b>Winair</b>	31.17	18.37	25.1	18.4
<b>Total</b>	<b>24.29</b>	<b>36.17</b>	<b>47.76</b>	<b>40.71</b>

Source: ECLAC estimates based on SLASPA data

**(b) Estimate of damage and losses**

An assessment of damages and losses for this subsector revealed that there were no damages accounted for. Losses within this subsector equaled EC\$999,417.

**(c) Comments and recommendations for improvements**

A review of lost landing fees at the two airports revealed that the majority of the landing fees lost were attributable to Hewanorra, simply because the application of landing fees by SLASPA are based on aircraft weight. One recommendation that might be considered, and which is aimed at reducing the vulnerability of the airports under SLASPA management would be for a review of the airport/runway drainage to be carried out, with the objective of reducing runoff of water and mud to the runway during a high rainfall event.

**5. TRANSPORTATION - ROADS AND BRIDGES**

**(a) Description of damage**

The road infrastructure in Saint Lucia suffered badly from the effects of Hurricane Tomas. Almost all of the damages experienced were as a result of landslide action (mass slope movement), river bed erosion or river sedimentation. Map 5 shows in a summary format the areas of the island that were most seriously affected.

**Map 5: Sections of roadway affected by the storm**



Immediately after the event, and subsequent to the announcement of a declaration of disaster on 31 October 2010 by the Prime Minister, the National Damage and Needs Assessment Committee of the National Emergency Management Advisory Council (NEMAC) commissioned the assistance of APESL. APESL then organized a team of volunteer engineers to carry out damage assessments of road infrastructure, housing and settlements, geotechnical assessment on: roads and settlements, institutions and public buildings, and river training requirements. Information generated by these teams of engineers was combined with information generated by staff from the Ministry of Works during their site visits.

The field visits confirmed that for the category of roads and settlements there had been major landslides in:

- The east and south of Castries and particularly in the residential communities of Morne, Derriere, Fort, Bagatelle, Forestiere and Babonneau.
- The centre of the island, and particularly along the Barre de L'Isle and Millet roadways and along the access to the Roseau Dam.
- The Soufriere area, and particularly in the Columbette and Fond St Jacques areas.



**Columbette landslide**



**Fond St Jacques**



**Steep Slopes on Barre de L'Isle Roadway**

For road infrastructure, the engineering assessments covered portions of the main roads from Barre de L'Isle through Cul-de-Sac to Soufriere and included bridges along the John Compton Highway. Bridges along this highway include the Choc and Bois D'Orange Bridges.



**Barre de L'Isle Road Failure**



**Choc Bridge**



In addition to the inventories done by the volunteer engineers, the Ministry of Works staff also carried out extensive field investigations. In developing the estimates of damages and losses for this subsector, both sets of information were drawn on, which facilitated the production of a comprehensive listing of damaged road infrastructure.

Summary table 9 shows all roads considered in the damage and loss assessment.

**Table 9: Damaged road sections**

Roads	Description of Damages
<b>Agency: Ministry of Works</b>	
<i>Damages</i>	
Fond St. Jacques - 2 Miles of rebuilt roads and embankments	Roads damaged by landslides
Ravine Claire - Surfaces and embankments	Erosion of roadway
Ravine Claire - Drainage channels	"
Victoria - Surfaces and embankments	Roads damaged by landslides
Anse Galet - Drainage channels	"
Ravine Cacao - Surfaces and embankments	Erosion of roadway
Ravine Cacao - Drainage channels	"
East Coast Road - Surfaces and embankments	Retain slope; road edge retaining structures; repair road
East Coast Road - Road embankment failure	Reconstruct road embankment or provide alternative route
East Coast Road - Culverts	Reconstruct culvert inlets/outlets; reconstruct retaining rubble walls
Desruisseax - Bellevue (Landslip)	Cut road slope back to stable angle
Desruisseax - Bellevue (Roadway failure)	Reconstruction of culvert and road embankment
Bellevue to Grace Road	Cut road slope back to stable angle
Banse / La Grace	Cut road slope back to stable angle; Repair collapsed roadway
Banse / Darban	Cut road slope back to stable angle; re-stabilise roadway
Saltibus	Cut slope back to stable angle; retaining walls; realign roadway
	Cut slope back to stable angle; gabion basket retaining walls; replace causeway with culvert structure
Darban	"
Choiseul - Lamaze & Myers Bridge area	Cut road slope back to stable angle; clear debris from drains
	Cut road slope back to stable angle; clear debris from drains;
Choiseul - Vieux Fort/Soufriere Highway	restabilise roadway
	Cut road slope back to stable angle; clear debris from drains;
Choiseul - Morne Jacques & Environs	restabilise roadway
Ravine Lavee - Surfaces and Embankments	"
Ladera - Surfaces and embankments	"
Sulphur Sorings - Surfaces and embankments	"
Old Morne Road - Surfaces and embankments	"
Bagatelle - Road and Slope Reconstruction	Slope retainment; retaining walls; reinstate roads
Barre d'Isle - Surfaces and embankments	"
Ti Rocher (Castries) - Surfaces and embankments	Reconstruction of road edge; retaining wall
Ti Rocher (Castries - Bocage)	Reconstruction of road edge; retaining walls
Ti Rocher (Castries - Dier Fort link)	Construct retaining wall; evacuate homes
Vannard - Surfaces and embankments	"
Guesneau - Road realignment and reconstruction	"
Guesneau - Related structures in right of way	"
Guesneau - Road Reconstruction and Slope Rehabilitation	Land slippage leading to road loss
Forestiere	Landslide onto roadway - slope retainment
Bocage	Replace culvert/headwall; retaining wall
Ravine Chabot	Repair culvert/headwall; water control; evacuate homes
Trois Piton	Drainage control; slope retainment; spillway construction
Anse la Raye (Venus) - Surfaces and embankments	"
Canaries (Quarte Chemin) - Surfaces and embankments	"
Columbette - Quarte - Surfaces and embankments	"
Ti Colon - Surfaces and embankments	"
Anse la Verdue - Surfaces and embankments	"
Mon Repos	"

Source: Official Government of Saint Lucia data

Similarly, an inventory was made of all damaged bridges, based on the inventories of the volunteer engineers and from the Ministry of Works records. Table 10 lists these bridges.

**Table 10: Affected bridges**

<b>Bridges</b>
<p><b>Agency: Ministry of Works</b></p> <p><i>Damages</i></p> <ul style="list-style-type: none"> <li>Fond St. Jacques</li> <li>Cresslands - Bridge and River Training</li> <li>Grande Riviere de Mabouya Bridge</li> <li>Anse Galet - Culverts/New Bridge</li> <li>Mamiku Gardens - Replacement of Culverts</li> <li>Bois D'Orange - Repair/Replacement</li> <li>Choc - Replacement</li> <li>East Coast Road - Reconstruction of culverts; Construction of bridge with proper wingwalls</li> <li>Trou Masse - Reinstatement + Protection of Abutment Fill</li> </ul>

Source: Official Government of Saint Lucia data

In addition to the damage that was experienced to the roads and bridges infrastructure, the Ministry of Works was also responsible for repairs to water treatment facilities and to the Roseau Dam access road. The listing of facilities attended to is given in table 11.

**Table 11: Water supply support works**

<b>Water Supply Support Works</b>
<p><b>Agency: Ministry of Works for WASCO</b></p> <p><i>Damages</i></p> <ul style="list-style-type: none"> <li>Canaries Water Treatment Facility</li> <li>Ravine Poisson Water Treatment Facility</li> <li>Vannard Water Treatment Facility</li> <li>Roseau Dam Access Road</li> </ul>

Source: Official Government of Saint Lucia data

**(b) Estimate of damage and losses**

An estimate of damages and losses was made for the transportation subsector, based on the information provided from the DANA/Volunteer Engineers Reports, on the Ministry of Works field visits and damage estimates, and on estimates made from knowledge of the construction sector in Saint Lucia and through application of appropriate unit rates for assumed work required to achieve cleanup of debris. In particular, the assessment of losses for this subsector were based on assumptions made for equipment that would be required to effect cleanup of debris of a magnitude observed during the field visits. This included, de-silting of roads, clearing away vegetative debris, among others. Losses also included estimates of labour and materials to carry out the cleanup exercises. Finally, a small component of the losses included the use of ferries, catamarans and pirogues to carry people from the north to the south and *vice versa*.



The estimates obtained were:

- The total estimated damages were EC\$100,638,750
- The total estimated losses were EC\$46,020,000

**(c) Comments and recommendations for improvements**

The single largest component of damages and losses was attributable to the transportation subsector, which accounted for 37.5% of the overall infrastructure sector. This subsector, in conjunction with its associated human environment, was particularly vulnerable due to the proximity of infrastructure and settlements to geotechnical and hydraulic hazards. In particular, the majority of the roads that were damaged were subjected to either erosion, resulting from landslide of downslope areas adjacent to the roadway, or were covered totally by landslide from upslope areas. These slope failures also took out culverts and waterways. Detailed recommendations for stabilizing roads that were affected by slopes have been provided in another section of this report. These relate to slope stabilisation methods.

Damage to the bridges was primarily due to a number of factors: First, many, if not all of the bridges were culvert-type structures and not open span bridges. Their waterway areas were, therefore, not as efficient at passing debris as would be the case for open span bridges. Second, and directly as a result of the first factor, many of waterway areas of these bridges became clogged with debris once the rivers became swollen. Finally, while it is not known what criteria were used in the design of the bridge structures, it is apparent that Hurricane Tomas was a very extreme event, from the perspective of rainfall. Therefore, this storm event would have significantly exceeded the capacity of the bridges. Recommendations for these structures are as follows:

- Bridge structures for major rivers should be designed to pass at a minimum the 1:50-year flood event.
- The existing bridges should be replaced with open span structures, so that their waterway areas are greatly maximized.
- Proper design of wing walls should be incorporated into the design.

## **6. FOREST ROADS**

**(a) Description of damage**

Approximately 13 km of forest roads were damaged as a result of Hurricane Tomas. The majority of these damages was as a result of landslides, downed trees, surface erosion and washed out bridges. Table 12 summarizes the damage.

**Table 12: Damage to forest roads**

Locations	Type of damage	Intensity of damage	Remarks
Edmund forest (6 km)	Landslides	high	Restoration feasibility low. Main road through Fond St Jacques is severely damaged
Barre de lisle (1 km)	Landslides and obstacles (trees)	low	Rehabilitation feasibility high
Forestiere (1 km)	Landslides	High	Restoration feasibility very low due to two major landslides
Logging Bay/Louvette (2km)	Obstacle trees and surface erosion	low	Sustained very little damage. Restoration feasibility high
La Porte (3 KM)	Landslides Loss of bridges	high	Damaged bridges due to two major landslides renders feasibility low to moderate

Source: Official Government of Saint Lucia data

Damage also occurred to forest trails. In all, approximately 54 km of trails were damaged, largely as a result of landslides, fallen trees as obstacles, and erosion of the trail surface. Many of these trails had small bridges associated with them. Some of these trails were deemed restorable, while a few were not considered to be restorable.

**(b) Estimate of damage and losses**

An assessment of damages and losses for this subsector was made using the known unit rates for sub-base, base and surface cover materials. Roads were assumed to be approximately 8 metres wide, while trails were assessed to be 5 metres wide. The analysis revealed that there were no losses accounted for. **Damages** within this subsector were estimated at **EC\$17,838,400**.

**(c) Comments and recommendations for improvements**

No specific comments and/or recommendations are suggested for this subsector.

## 7. RIVER TRAINING

**(a) Description of damage**

A large number of rivers were identified as candidates for river training and de-silting. In many cases, the flow in these rivers so greatly exceeded their capacities that the river banks overflowed and extensive siltation of adjacent areas occurred. The rivers that were included in the analysis are summarized in table following.

**Table 13: Rivers that require river training**

River	Remarks
Cul-de-Sac River	Bexon area
Soufriere River	Fond St. Jacques – embankment stabilization and river training
Marc River	
Roseau River	
Choc River	
Canaries River	
Castries River	
Dennery River	
Anse La Raye	
Fond D'Or River	
Mamiku River	
Fond River	

Source: Official Government of Saint Lucia data

The photograph below shows an example of the siltation that occurred in Bexon.



**Cul-de-Sac River – Bexon Area**

**(b) Estimate of damages and losses**

An assessment of damages and losses for this subsector was made using information provided by the Ministry of Works (to assess damages) and from an assumption of volumes of material that would need to be excavated and removed, the equipment that would be required to move this material and the unit rates for the equipment (to estimate losses). **Damages** within this subsector were estimated at **EC\$35,000,000**, while **losses** were estimated at **EC\$53,155,000**.

**(c) Comments and recommendations for improvements**

In order to properly assess the floodplain areas for the affected rivers, it is first necessary to carry out hydraulic and hydrological analyses for the 1 in 25, 50 and 100 year return period events. Once these investigations were completed, then hazard mapping can be carried out and, where necessary, relocation of affected housing and settlements should be carried out in an informed manner.

## 8. SUMMARY COSTS

A summary of all costs developed under the infrastructure heading is presented in table 14, and the breakdown is shown in figure 10.

**Table 14: Summary of damage and losses caused by Hurricane Tomas**

Summary of damage and losses caused by Hurricane Thomas in St. Lucia Eastern Caribbean Dollars Damage and losses				Sector	
Sector and Subsector	Total	Damages	Losses	Public	Private
<b>Infrastructure</b>	<b>391,550,362</b>	<b>210,877,650</b>	<b>180,672,712</b>		
Electricity	8,339,726	3,500,000	4,839,726		
Water supply	119,469,453	53,016,600	66,452,853		
Roads	120,977,500	74,957,500	46,020,000		
Bridges	20,681,250	20,681,250	0		
Water Supply Support Works	5,000,000	5,000,000	0		
River Training	88,155,000	35,000,000	53,155,000		
Telecommunications	10,089,615	883,900	9,205,715		
Forest Roads	17,838,400	17,838,400	0		
Airports and Seaports	999,417	0	999,417		

Source: ECLAC estimates based on official Government of Saint Lucia data

**Figure 10: Distribution of the impact on the infrastructure sector**

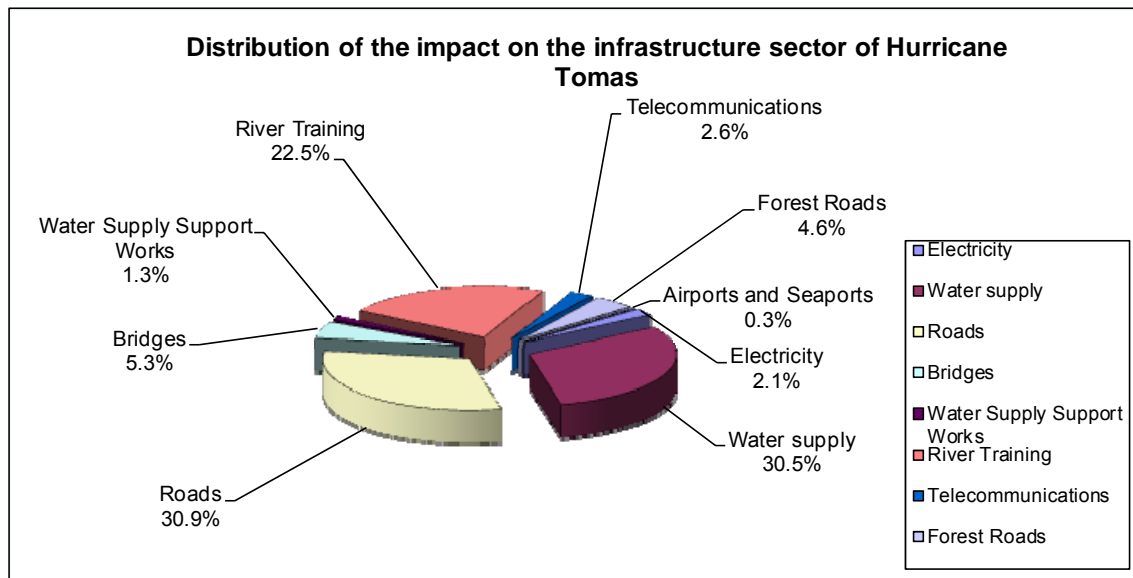

Source: ECLAC estimates based on official Government of Saint Lucia data

## B. AGRICULTURE

### 1. OVERVIEW OF THE NATIONAL ECONOMY

The economic performance of Saint Lucia in the recent past (2006-2009) may be characterized as moderate and losing momentum, with real Gross Domestic Product (GDP) decreasing from 4.8% in 2006, to 0.7% in 2008 and negative (5.2%) in 2009. The economy was projected to grow by 1.4% in 2010 (figure 11).

Figure 11: Real growth rate in GDP (2006-2010)

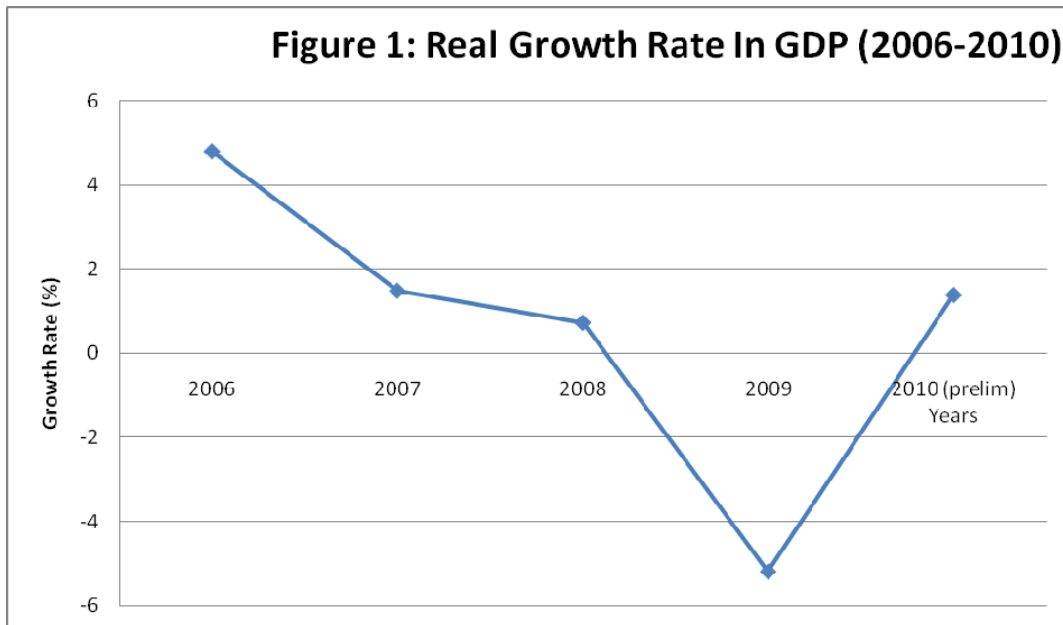

Source: Eastern Caribbean Central Bank

The economic performance of Saint Lucia during the period 2006 and 2010 was to a large extent influenced by the global financial crisis where the world economy experienced huge declines in growth and concomitant reductions in employment. The effect of the world crisis led to a reduction in tourist arrivals and a general plunge in output in the manufacturing, agriculture and construction sectors.

The general contraction of the economic performance over the period was also influenced by weak domestic and external demand, which led to a fall in foreign direct investment and, by extension, an increase in unemployment. A fall in world oil prices from the high prices of 2009, led to a relatively stable rate of inflation in 2009.

Revenues declined over the period under review, while the government was forced to increase expenditure on salaries and social programmes aimed at protecting vulnerable groups and stimulating economic activity.

## 2. THE AGRICULTURAL SECTOR

### (a) Performance of the agricultural sector

The agricultural sector is critical to the economy of Saint Lucia and although its contribution to GDP over the last five years has fluctuated, with an upward tendency, the sector continues to play an important role in the country's socio-economic development. The sector plays a multi-functional role in earning foreign exchange, generating employment and contributing towards economic growth and food and nutrition security.

In 2005, for instance, the sector accounted for 3.90% of total GDP, compared to 4.76% in 2008 and 4.61% in 2009.

The contribution of the various subsectors to total agricultural GDP is presented in figure 12, which clearly demonstrates the importance of the banana industry to the agricultural sector.

Figure 12: Contribution of the various subsectors to agricultural GDP

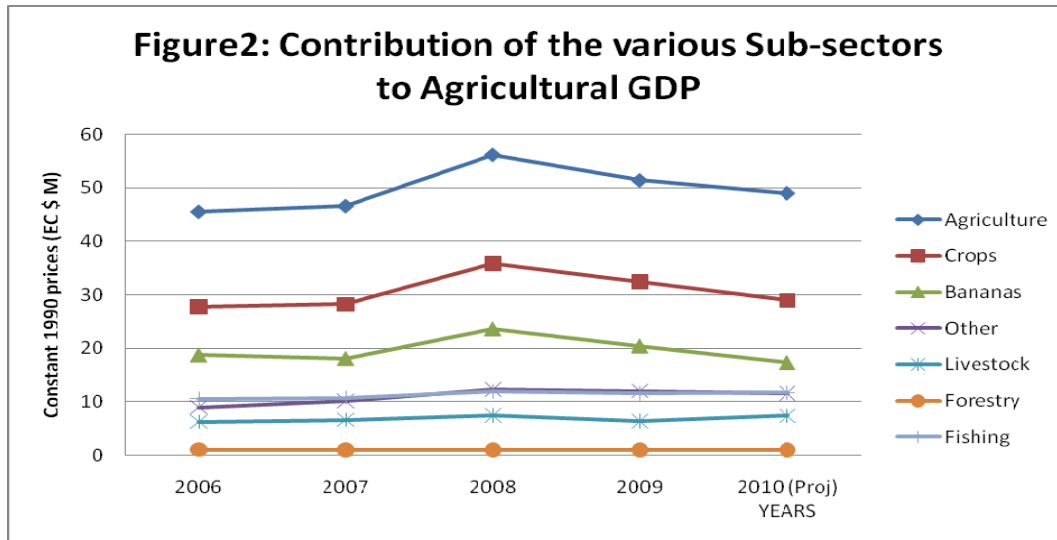

Source: ECLAC estimates based on official Government of Saint Lucia data

Table 15 presents the growth rates of the agricultural sector as well as for the various subsectors for the period 2005-2009, and projections for 2010.

Table 15: Rate of growth of GDP by agricultural activity at basic prices in constant prices

YEAR/ SUBSECTOR	2005	2006	2007	2008	2009	2010
Agriculture	-24.74	9.77	2.34	20.51	-8.49	-4.65
Crops	-34.43	10.84	1.86	26.91	-9.41	-10.81
Bananas	-37.19	11.40	-3.41	30.02	-13.24	-15
Other Crops	-27.88	9.69	12.93	21.33	-2.03	-3.67
Livestock	2.22	-9.68	5.60	11.97	-13.91	15.77
Forestry	-3.57	-2.78	-3.81	-0.99	-1.00	0.00
Fishing	-6.81	24.06	2.28	10.97	-3.00	0.98

Source: ECLAC estimates based on official Government of Saint Lucia data

The table shows that in 2009, the agricultural sector recorded a poor performance when compared with 2008. The sector contracted by 8.5% as a result of a fall in banana output and contractions in the other crops, livestock, forestry and fisheries subsectors.

Banana exports to the United Kingdom declined by 11.6% to 33,925 tonnes in 2009. This was mainly due to difficulties in controlling the rapid spread of the leaf spot disease. Exports to the Caribbean subregion, however, doubled in 2009, and the volume of bananas sold to supermarkets increased by 21.5%.

Despite the 2% decline in output of the other crops category, there was an increase in the volume of non-traditional crops purchased by supermarkets, hotels and exported. Total domestic sales to supermarkets and hotels increased considerably, with supermarket purchases accounting for 38.6% of total purchases. A major factor attributing to this increased purchase by the supermarkets was the

introduction of a Farmer Certification Programme, which led to the enhancement of agricultural production of some key locally traded commodities, the strengthening of marketing linkages between farmers and purchasers, as well as the provision of improved technical assistance to farmers.

The livestock subsector experienced a decline of 13.9 % in 2009, as a result of declines in the major industries, while the fisheries subsector declined by 3.0%.

In terms of foreign exchange earnings, the agricultural sector accounts for approximately 37.6% (EC \$70.4 million) of total domestic exports of EC \$186.9 million in 2009 (table 16). Banana exports was 83.9% (EC \$59.0 million) of total agricultural exports in 2009.

**Table 16: Domestic, agricultural and banana exports (EC\$'000), 2005-2009**

YEAR	Total Domestic Exports	Total Agricultural Exports (2)	Total Banana Exports (3)	Agricultural Exports as % of Total Domestic	Banana Exports as % of Total Agricultural
2005	95,943	36,604	32,675	38.3	89.3
2006	140,301	51,508	47,701	36.7	92.6
2007	142,300	40,576	35,626	28.5	87.8
2008	185,772	65,796	59,927	35.4	91.1
2009 1 <sup>st</sup> Quart	36,712	16,189	15,316	44.1	94.6
2 <sup>nd</sup> Quart	42,549	16,035	13,452	37.7	83.9
3 <sup>rd</sup> Quart	52,838	16,902	13,893	32.0	82.2
4 <sup>th</sup> Quart	54,781	21,231	16,350	38.8	77.0
<b>Total 2009</b>	<b>186,881</b>	<b>70,357</b>	<b>59,011</b>	<b>37.6</b>	<b>83.9</b>

Source: Foreign Trade Report

## 2. RESOURCE BASE

### (a) Land capability

Table 17 presents the land capability classification of Saint Lucia and its total land area and cultivation possibilities. The table demonstrates the skewed distribution of land capability classes in the country. The predominance of Class VII and the lack of suitable agricultural lands in the desirable Classes I- IV are quite evident.

The factors that render land areas unsuitable for agriculture are steep slopes, shallow soil, stoniness, low fertility and aridity.

Lands suitable for intensive agriculture, Classes I-IV, cover only about 8,400 acres or 5.6% of the total area of the country's land mass. Efforts must, therefore be made to maintain these high potential lands in agricultural production and restrict their use for urban and industrial activities, housing and hotel construction.

**Table 17: Land Capability Classes, Total Area and Cultivation Possibilities**

Land Class	Land Area (Acres)	% of Total Areas	Cultivation Possibilities
I	3,989.70	2.65	Cultivable
II	1,422.03	0.94	Cultivable
III	1,809.57	1.20	Cultivable
IV	1,178.08	0.78	Limited cultivation
V	5,757.58	3.82	Pasture
VI	25,477.51	16.90	Permanent Crops
VII	101,050.70	67.01	Timber, Natural Forest
VII	10,103.90	6.70	National Parks
<b>Total</b>	<b>150,789.07</b> <b>235.6 sq. miles</b>	<b>100.00</b>	

Source: OAS Saint Lucia National Resources and Agricultural Development Project, 1986.

## (b) Farm holdings

Table 18 depicts a general outlook of the agricultural sector in Saint Lucia in 2007 according to the census results.

**Table 18: General Agricultural Census Results on Farm Holdings, 2007**

Total Household Members in Holdings	<b>32,919</b>
Average Size of Holder's Household	<b>3.30</b>
Number of Holding (landless included)	<b>9,972</b>
Number of holdings with Land	<b>9,448</b>
Total Holding Area	<b>30,204.33</b>
Average Size of Holdings (acres)	<b>3.20</b>
Number of individual Female Holders	<b>2,906</b>
Number of Individual Male holders	<b>6,894</b>
Median Age of individual Female Holders	<b>51</b>
Median Age of individual Male Holders	<b>50</b>
Number of parcels	<b>11,503</b>
Average Number of parcels per holding	<b>1.23</b>

Source: Saint Lucia Agricultural Census, 2007

The census has identified 9,972 holdings (landless included), with an average size of 3.2 acres and a total household membership of 32,919 (3.3 persons per household). The most significant findings of the 2007 Census of Agriculture is the decline in the number and area of agricultural holdings. Such an occurrence is reflective of the new transfer of resources from agriculture and the impact of trade liberalization. The dismantling of preferential trading arrangements has resulted in the sharp decline in banana production and significant reduction in agricultural export earnings.

The table shows that the typical Saint Lucian farmer is a male, operating on a holding of 3.2 acres in size in only one parcel of land, and living in a three to four person household.

Table 19 presents data on the total number of agricultural holding recorded in the last five agricultural censuses. The table clearly demonstrates that the number of holdings recorded in 2007 are at the lowest since 1961.



**Table 19: Total Number of Holdings by Census Year**

Year	Number of Holdings
1961	13,008
1973/74	10,938
1986	11,551
1996	13,388
2007	9,972

Source: Saint Lucia Agricultural Census, 1961, 1973/74 1986, 1996, 2007.

As can be gleaned from table 20, the administrative districts of Soufriere, Canaries, Anse La Raye and Gros Islet reflect the highest decrease in the number of holdings between 1996 and 2007.

**Table 20: Number of Holdings by Administrative District**

Administrative District	1986		1996		2007		% Change: 1996/2007
	No. of holdings	%	No. of holdings	%	No. of holdings	%	
Castries	2,611	22.6	3,160	23.6	2,345	23.5	-25.8
Anse La Raye	406	3.5	708	5.3	434	4.4	-38.7
Canaries	189	1.6	140	1.1	81	0.8	-42.1
Soufriere	855	7.4	792	5.9	455	4.6	-42.6
Choiseul	994	8.6	913	6.8	849	8.5	-7.0
Laborie	819	7.1	887	6.6	769	7.7	-13.3
Vieux Fort	1,332	11.5	1,399	10.5	1,021	10.2	-27.0
Micoud	1,693	14.7	2,464	18.4	2,008	20.1	-18.4
Dennerly	1,389	12.1	1,397	10.5	987	9.9	-29.3
Gros Islet	1,263	10.9	1,508	11.3	1,023	10.3	-32.2
<b>Total</b>	<b>11,551</b>	<b>100.0</b>	<b>13,366</b>	<b>100.0</b>	<b>9,972</b>	<b>100.0</b>	<b>-25.4</b>

Source: Saint Lucia Agricultural Census, 1986, 1996, 2007.

However, in terms of land area reduction, the districts of Canaries, Soufriere, Anse La Raye and Vieux Fort suffered the most reductions (table 21).

**Table 21: Total Areas on Holdings by Administrative District (Acres)**

Administrative District	1986		1996		2007		% Change: 1996/2007
	Total area on holdings	%	Total area on holdings	%	Total area on holdings	%	
Castries	7,553.9	12.9	11,416.2	22.2	6,478.1	21.4	-43.3
Anse La Raye	4,454.0	7.7	3,674.5	7.2	1,701.6	5.6	-53.7
Canaries	1,630.4	3.1	1,590.1	3.1	415.6	1.4	-73.9
Soufriere	5,988.2	10.3	3,784.3	7.4	1,490.2	39.4	-60.6
Choiseul	1,941.3	3.4	1,553.1	3.0	1,503.0	5.0	-3.2
Laborie	3,588.0	6.2	3,089.3	6.0	1,820.5	6.0	-41.1
Vieux Fort	5,251.8	9.0	4,033.7	7.9	1,985.2	6.6	-50.8
Micoud	12,416.4	21.4	10,810.7	21.1	7,047.2	23.3	-34.8
Dennerly	8,037.9	14.7	5,688.4	11.1	4,579.3	15.2	-19.5
Gros Islet	7,154.5	12.3	5,682.8	11.0	3,183.6	10.5	-43.9
<b>Total</b>	<b>58,016.5</b>	<b>100.0</b>	<b>51,323.1</b>	<b>100.0</b>	<b>30,204.3</b>	<b>100.0</b>	<b>-41.1</b>

Source: Saint Lucia Agricultural Census, 1986, 1996, 2007.

As can be seen in tables 22 and 23, most of the reduction in the number of holdings took place in the larger farm size categories.

**Table 22: Number of Holdings by Holding Size**

Size Group (Acres)	1986		1996		2007		% Change: 1996/2007
	Total Number of holdings	%	Total Number of holdings	%	Total Number of holdings	%	
Landless	850	7.4	1,630	12.2	524	5.3	-67.9
Up to 4.9 acres	8,770	75.9	9,166	68.6	7,763	77.8	-11.5
5 to 9.9 acres	1,191	10.3	1,713	12.8	1,156	11.6	-32.5
10 to 24.9 acres	560	4.9	700	5.2	454	4.6	-35.1
25 to 49.9 acres	98	0.9	92	0.7	51	0.8	-44.6
50 to 99.9 acres	35	0.3	27	0.2	13	0.1	-51.9
100 acres and over	47	0.5	38	0.3	11	0.1	-71.1
<b>Total</b>	<b>11,551</b>	<b>100.0</b>	<b>13,366</b>	<b>100.0</b>	<b>9,972</b>	<b>100.0</b>	<b>-25.4</b>

Source: Saint Lucia Agricultural Census, 1986, 1996, 2007.

**Table 23: Distribution of Holding Areas (acres) by Holding Size**

Size Group (Acres)	1986		1996		2007		% Change: 1996/2007
	Total Number of holdings	%	Total Number of holdings	%	Total Number of holdings	%	
Up to 4.9 acres	12,350.0	21.3	13,521.1	26.4	9,780.3	32.4	-27.7
5 to 9.9 acres	7,802.4	13.4	10,898.7	21.2	7,276.9	24.1	-33.2
10 to 24.9 acres	7,763.1	13.4	9,375.3	18.3	6,059.9	20.0	-35.4
25 to 49.9 acres	3,218.6	5.6	3,072.2	6.0	1,751.1	5.8	-43.0
50 to 99.9 acres	2,338.0	4.0	1,625.9	3.2	820.0	2.7	-49.6
100 acres and over	24,544.4	42.3	12,829.9	24.9	4,516.1	15.0	-64.8
<b>Total</b>	<b>58,016.5</b>	<b>100.0</b>	<b>51,323.1</b>	<b>100.0</b>	<b>30,204.3</b>	<b>100.0</b>	<b>-41.1</b>

Source: Saint Lucia Agricultural Census, 1986, 1996, 2007.

The decreases in the number of holdings and the agricultural area between 1996 and 2007 have had as a consequence a change in the size structure of holdings. In fact while in 1996, 86.6% of small holdings (25 acres and less) with land held 65.9% of the land, in 2007, 94 % of small holdings occupied 76.5% of the land.

### (c) Land tenure

Table 24 shows that the structure of land tenure has changed significantly between 1986 and 2007. Family owned lands is now the predominant form of land tenure (41.9%).

**Table 24: Land Tenure Structure (1986, 1996, 2007) – Areas of Holdings**

Land Tenure (Areas of Holdings)	1986 (%)	1996 (%)	2007 (%)
Owned	60.2	52.1	39.7
Family Land	24.4	29.8	41.9
Rented/Leased Land (Private)	6.7	8.6	10.4
Rented/Leased Land (Government)	1.8	4.9	3.1
Squatting Private Lands	2.0	1.4	1.5
Squatting Government Lands	1.6	1.5	2.2
Others	3.3	1.8	1.1
Total	<b>100.0</b>	<b>100.0</b>	<b>100.0</b>

Source: Saint Lucia Agricultural Census, 1986, 1996, 2007

### 3. TOTAL DAMAGE TO THE AGRICULTURAL SECTOR

#### (a) Overview

Damage caused to the agricultural sector by Hurricane Tomas at the time of the disaster is categorized as 'Damage'. Damage that will have a negative impact on production and income throughout the recovery period was assessed as 'Loss'.

The impact of Hurricane Tomas was widespread throughout the country, inflicting substantial environmental damage to the agricultural sector. The damage was concentrated in Regions 4, 7, 3 and 5, where extensive damages were recorded as a result of high rainfall and, to a lesser extent, winds associated with the hurricane. However, the damage was most severe in Regions 4, 7 and 3, which accounted for, 26.1%, 19.2% and 18.6% of the total damage, excluding fisheries and forestry.

The ECLAC methodological framework for estimating the socio-economic and environmental effects of disasters was utilized in assessing the damage in the agricultural sector. Within this context, damage to the sector was categorized under two broad headings, damage and losses.

In assessing the damage to the sector, only damage to capital assets and stocks were considered. The damages were identified under four broad headings:

- (a) Damage to farmlands
- (b) Damage to the physical infrastructure and to machinery and equipment
- (c) Damage of crops that were ready to be harvested at the time of the event
- (d) Damage of stocks (livestock, inputs, harvested products, etc).

In assessing the damage, only production ready to be harvested at the time of the hurricane was taken into consideration. However, for affected annual crops that were still growing at the time of the event, the investments in the production processes (labour and inputs) were considered.

In the case of damages of stock, damages were estimated at farm prices and input at replacement value. Assessments for partial damages were estimated on a prorated basis.

Tables 25 through 27 provide a summary of the Total Damage, Damage and Loss, respectively, of Hurricane Tomas to the banana, 'other crops', livestock, fisheries and forestry subsectors, as well as to infrastructure. On-farm infrastructural damages to the livestock are included in the livestock subsector.

Damages to farm roads are not included in the estimates, as this is addressed under the Communication, Transport and Works sector

The total damage to the agricultural sector is estimated at EC \$151.75 million, of which damage is estimated at EC \$108.82 million and losses at EC \$42.93 million (table 25). Of the total damage, the forestry subsector accounted for 37.0%, while total damage to the banana sub-sector was 36.0%. Significant damages were also incurred by the agricultural infrastructure (17.4%) and 'other crops' sub-sector (8.0%). Details of Damage and Losses by region and sector are presented in table 26 and table 27, respectively.

**Table 25: Total estimated damage to the agricultural sector**

Region	Bananas	Other Crops	Livestock	Fisheries	Forestry	Infrastructure	Total Cost
1	90,288	293,650	15,675			4,510,700	4,910,313
2	2,989,626	53,650	113,825			307,600	3,464,701
3	13,693,551	1,211,120	117,595			2,514,400	17,536,666
4	17,533,487	799,100	15,655			6,185,000	24,533,242
5	10,166,807	69,820	262,850			219,200	10,718,677
6	70,873	9,021,310	67,640			695,400	9,855,223
7	5,908,992	520,900	171,150			11,493,350	18,094,392
8	4,227,030	146,330	291,610			305,200	4,970,170
<b>OTHERS</b>				1,616,564	56,046,530		57,663,094
<b>Sub-total</b>	<b>54,680,654</b>	<b>12,115,880</b>	<b>1,056,000</b>	<b>1,616,564</b>	<b>56,046,530</b>	<b>26,230,850</b>	<b>151,746,478</b>
<b>Percentage</b>	<b>36.0</b>	<b>8.0</b>	<b>0.7</b>	<b>1.0</b>	<b>37.0</b>	<b>17.3</b>	<b>100.0</b>

Source: ECLAC estimates based on official Government of Saint Lucia data

**Table 26: Estimate of damage to the agricultural sector**

Region	Bananas	Other Crops	Livestock	Fisheries	Forestry	Infrastructure	Total Cost
1	62,154	202,750	13,150			769,000	1,047,054
2	2,058,050	38,250	86,175			287,900	2,470,375
3	9,426,601	756,950	91,195			1,229,200	11,503,946
4	12,070,002	515,550	12,955			1,387,900	13,986,407
5	6,998,801	48,150	198,130			175,100	7,420,181
6	48,789	5,622,750	55,290			663,900	6,390,729
7	4,067,733	308,600	138,810			3,201,600	7,716,743
8	2,909,875	96,320	243,060			270,600	3,519,855
<b>OTHER</b>				1,384,000	53,377,650		54,761,650
<b>TOTAL</b>	<b>37,642,005</b>	<b>7,589,320</b>	<b>838,765</b>	<b>1,384,000</b>	<b>53,377,650</b>	<b>7,985,200</b>	<b>108,816,940</b>
<b>Percentage</b>	<b>34.6</b>	<b>6.9</b>	<b>0.8</b>	<b>1.3</b>	<b>49.1</b>	<b>7.3</b>	<b>100.0</b>

Source: ECLAC estimates based on official Government of Saint Lucia data

**Table 27: Estimated loss to the agricultural sector**

Region	Bananas	Other Crops	Livestock	Fisheries	Forestry	Infrastructure	Total Cost
1	28,134	90,900	2,525			3,741,700	<b>3,863,259</b>
2	931,576	15,400	27,650			19,700	<b>994,326</b>
3	4,266,950	454,170	26,400			1,285,200	<b>6,032,720</b>
4	5,463,485	283,550	2,700			4,797,100	<b>10,546,835</b>
5	3,168,006	21,670	64,720			44,100	<b>3,298,496</b>
6	22,084	3,398,560	12,350			31,500	<b>3,464,494</b>
7	1,841,259	212,300	32,340			8,291,750	<b>10,377,619</b>
8	1,317,155	50,010	48,550			34,600	<b>1,450,315</b>
<b>OTHER</b>				232,564	2,668,880		<b>2,901,444</b>
<b>TOTAL</b>	<b>17,038,649</b>	<b>4,526,560</b>	<b>217,235</b>	<b>232,564</b>	<b>2,668,880</b>	<b>18,245,650</b>	<b>42,929,538</b>
<b>Percentage</b>	<b>39.7</b>	<b>10.5</b>	<b>0.5</b>	<b>0.5</b>	<b>6.2</b>	<b>42.5</b>	<b>100.0</b>

Source: ECLAC estimates based on official Government of Saint Lucia data

## (b) Banana industry

The banana industry has played an important role in the economy of Saint Lucia contributing significantly to GDP, foreign exchange earnings and employment. Analysis of available disaggregated data shows that the contribution of the industry to total GDP for the period 2004 to 2009, varies from a high of 2.27% in 2004 to a low of 1.41% in 2005. In 2009, the contribution of the industry to GDP was 1.82%. The data also shows that in 2009 the contribution of the banana industry to total agricultural GDP was 67.77%.

Table 16 demonstrates that the banana industry is a major contributor to export earnings in Saint Lucia. Table 28 shows the production of banana in St. Lucia for the period 2007 -2010.

**Table 28: Banana production 2007-2010**

YEAR	PRODUCTION (TONNES)
<b>2007</b>	30,091
<b>2008</b>	38,465
<b>2009</b>	33,892
<b>2010 (October)</b>	21,701

Source: ECLAC estimates based on official Government of Saint Lucia data

The banana industry is also a significant contributor to employment in Saint Lucia. It is estimated that there are 1,330 active banana farmers operating on about 7,361 acres of land and employing approximately 4,000 workers.

The banana industry was heavily impacted by Hurricane Tomas, with some farmers occupying approximately 6,480 acres affected. Total impact of the disaster on the industry is estimated at EC \$54.68 million. The damage is estimated at EC \$37.64 million, while the losses are put at EC \$17.04 million.

The impact of the disaster was more pronounced in Region 4, 3 and 5, which reported estimated total impact of EC \$17.53 million, EC \$13.69 million, and EC \$10.17 million, respectively. Approximately 2,078 acres in Region 5, 1,623 acres in Region 3, and 1,205 acres in Region 3 were impacted.

The overall impact of the hurricane on the banana industry was estimated at 88.0%. See table 29 for details.

**Table 29: Total Damage to the Banana Industry**

Region	Number of Farmers Affected	Acreages under Production	Acreages Affected	% Acreages Affected	Crop Direct Damage Estimate	Indirect Crop Losses	Total Crop Damage Estimate
1	2	15.4	10.7	71.3	62,154	28,134	90,288
2	62	384	355	92.4	2,058,050	931,576	2,989,626
3	408	1,879	1,623	86.4	9,426,601	4,266,950	13,693,551
4	357	2,268	2,078	91.6	12,070,002	5,463,485	17,533,487
5	275	1,357	1,205	88.8	6,998,801	3,168,006	10,166,807
6	4	11.5	8.4	73.0	48,789	22,084	79,873
7	134	900	699	77.7	4,067,733	1,841,259	5,908,992
8	66	546	501	91.8	2,909,875	1,317,155	4,227,030
<b>Total Damage</b>	<b>1330</b>	<b>7,360.9</b>	<b>6,480.1</b>	<b>88.0</b>	<b>37,642,005</b>	<b>17,038,649</b>	<b>54,680,654</b>

Source: ECLAC estimates based on official Government of Saint Lucia data

The impact of the hurricane on the industry obviously will have serious implications for future banana production as well as for farmers and export income. These implications are presented in table 30. The country is expected to have a shortfall in banana export earnings of EC \$9.27 million in value up to the middle of August 2011.

**Table 30: Implications of Hurricane Tomas on Banana Production, Income and Export Earnings**

Year	Pre-Tomas Expected Production (Tonnes)	Post-Tomas Projected Production (Tonnes)	Production Losses (Tonnes)	Projected income Losses (EC\$)	Projected Export Earnings Losses (EC\$)
2010	29,000	21,941	7,059	6,423,690	9,268,467
Jan – mid-August 2011	20,700	9,040	11,660	10,610,600	15,309,580
<b>Total</b>	<b>49,700</b>	<b>30,981</b>	<b>18,719</b>	<b>17,037,290</b>	<b>24,578,047</b>

Source: ECLAC estimates based on official Government of Saint Lucia data

### (c) Other crops

The category 'Other crops', which included legumes, root crops, fruits and vegetables and fruit trees were also heavily impacted, with total impact on the subsector estimated at EC \$12.12 million. The damage was estimated at EC \$7.59 million and the losses put at EC \$4.53 million (table 31)

Region 6 accounted for 74.4% of the total damage. Production in areas such as Fond St Jacques was totally devastated.

**Table 31: Total damage to the other crops subsector (EC\$)**

Region	Direct Damage	Indirect damage (Losses)	Total Damage
1	202,750	90,900	293,650
2	38,250	15,400	53,650
3	756,950	454,170	1,211,120
4	515,550	283,550	799,100
5	48,150	21,670	69,820
6	5,622,750	3,398,560	9,021,310
7	308,600	212,300	520,900
8	96,320	50,010	146,330
<b>Total</b>	<b>7,589,320</b>	<b>4,526,560</b>	<b>12,115,880</b>

Source: ECLAC estimates based on official Government of Saint Lucia data

**(d) Livestock industry**

The livestock subsector suffered moderate damage as a result of the hurricane. Regions 8, 5 and 7 were the regions most seriously impacted.

The overall estimate of damage to the livestock industry is put at EC \$1.06 million, with EC \$838,765 representing damage and EC \$217,235 losses. The loss of animals, mainly through drowning, was the area most impacted, with damage estimated to this area put at EC \$734,030 or 69.5% of total livestock damage. Damage to livestock infrastructure was moderate, including damage to houses (mainly roof of farm buildings) and fencing.

Highest damages to the livestock industry were recorded for poultry and cattle, with the value of total damages estimated at EC \$0.424 million and EC \$ 0.31 million, respectively. See tables 18,19 and 20 for details.

Table 32: Estimated total damage to the livestock subsector

Region	Swine			Total Swine	Poultry			Total Poultry	Small Ruminants			Sub-Total Sm.Rum.	Cattle			Total Cattle	Others	Grand Total
	Animal	Feed	Infrast.		Animal	Feed	InFrast.		Animal	Feed	Infrast		Animal	Feed	Infrast.			
1	3,010	3,520	7,440	13,970	495	150	1,060	1,705	-	-	-	--	-	-	-	-	-	15,675
2	20,980	465	8,725	30,170	69,390	1,160	7,080	77,630	740	-	5,285	6,025	-	--	-	-	-	113,825
3	34,745	4,310	19,985	59,040	25,155	-	3,170	28,325	740	4,825	3,165	8,730	21,500	-	-	21,500	-	117,595
4	10,530	-	2,980	13,510	945	-	-	945	-	-	-	-	-	-	-	-	1,200	15,655
5	105,200	315	49,540	155,055	-	9,460	2,420	11,880	17,600	-	41,005	58,605	6,990	-	-	6,990	30,320	262,850
6	46,655	-	4,540	51,195	2,845	-	-	2,845	4,400	-	615	5,015	-	8,585	-	8,585	-	67,640
7	13,185	-	-	13,185	5,400	-	-	5,400	3,980	16,185	-	20,165	129,320	-	-	129,320	3,080	171,150
8	59,575	1,855	26,800	88,230	4,250	-	-	4,250	5,400	-	-	5,400	141,000	-	2,860	143,860	49,870	291,610
<b>TOTAL</b>	<b>293,880</b>	<b>10,465</b>	<b>120,010</b>	<b>424,355</b>	<b>108,480</b>	<b>10,770</b>	<b>13,730</b>	<b>132,980</b>	<b>32,860</b>	<b>21,010</b>	<b>50,070</b>	<b>103,940</b>	<b>298,810</b>	<b>8,585</b>	<b>2,860</b>	<b>310,255</b>	<b>84,470</b>	<b>1,056,000</b>

Source: ECLAC estimates based on official Government of Saint Lucia data

Table 33: Estimate of damage to the livestock subsector

Region	Swine			Total Swine	Poultry			Total Poultry	Small Ruminants			Sub-Total Sm.Rum.	Cattle			Total Cattle	Others	Grand Total
	Animal	Feed	Infrast.		Animal	Feed	InFrast		Animal	Feed	Infrast		Animal	Feed	Infrast			
1	2,280	3,500	6,000	11,780	350	140	880	1,370	-	-	-	--	-	-	--	-	-	13,150
2	15,800	345	6,580	22,725	51,390	1,080	5,900	58,370	600	-	4,480	5,080	-	-	-	-	-	86,175
3	26,825	4,150	15,580	46,555	18,900	-	2,640	21,540	600	4,500	3,000	8,100	15,000	-	-	15,000	-	91,195
4	9,640	-	2,490	12,130	825	-	-	825	-	-	-	-	-	-	-	-	-	12,955
5	73,100	300	40,500	113,900	-	8,800	2,210	11,010	14,800	-	36,000	50,800	6,300	-	-	6,300	16,120	198,130
6	36,700	-	4,540	41,240	2,400	-	-	2,400	3,700	-	550	4,250	-	7,400	-	7,400	-	55,290
7	10,140	-	-	10,140	4,500	-	-	4,500	3,490	15,000	-	18,490	105,600	-	-	105,600	80	138,810
8	49,560	1,750	15,900	67,210	3,250	-	-	3,250	4,700	-	-	4,700	125,400	-	2,500	127,900	40,000	243,765
<b>Total</b>	<b>224,045</b>	<b>10,045</b>	<b>91,590</b>	<b>325,680</b>	<b>81,615</b>	<b>10,020</b>	<b>11,630</b>	<b>103,265</b>	<b>27,890</b>	<b>19,500</b>	<b>44,030</b>	<b>91,420</b>	<b>252,300</b>	<b>7,400</b>	<b>2,500</b>	<b>262,200</b>	<b>56,200</b>	<b>838,765</b>

Source: ECLAC estimates based on official Government of Saint Lucia data



Table 34: Estimated loss incurred by the livestock subsector

Region	Swine			Total Swine	Poultry			Total Poultry	Small Ruminants			Sub-Total Sm.Rum.	Cattle			Total Cattle	Others	Grand Total
	Animal	Feed	Infrast.		Animal	Feed	InFrast.		Animal	Feed	Infrast		Animal	Feed	Infrast.			
1	730	20	1,440	2,190	145	10	180	335	-	-	-	--	-	-	--	=	-	2,525
2	5,180	120	2,145	7,445	18,000	80	1,180	19,260	140	-	805	945	-	-	-	-	-	27,650
3	7,920	160	4,405	12,485	6,255	-	530	6,785	140	325	165	630	6,500	-	-	6,500	-	26,400
4	890	-	490	1,380	120	-	-	120	-	-	-	-	-	-	-	-	1,200	2,700
5	32,100	15	9,040	41,155	-	660	210	870	2,800	-	5,005	7,805	690	-	-	690	14,200	64,720
6	9,955	-	-	9,955	445	-	-	445	700	-	65	765	-	1,185	-	1,185	-	12,350
7	3,045	-	-	3,045	900	-	-	900	490	1,185	-	1,675	23,720	-	-	23,720	3,000	32,340
8	10,015	105	10,900	21,020	1,000	-	-	1,000	700	-	-	700	15,600	-	360	15,960	9,870	48,550
<b>Total</b>	<b>69,835</b>	<b>420</b>	<b>28,420</b>	<b>98,675</b>	<b>26,865</b>	<b>750</b>	<b>2,100</b>	<b>29,715</b>	<b>4,970</b>	<b>1,510</b>	<b>6,040</b>	<b>12,520</b>	<b>46,510</b>	<b>1,185</b>	<b>360</b>	<b>48,055</b>	<b>28,270</b>	<b>217,235</b>

Source: ECLAC estimates based on official Government of Saint Lucia data

**(e) Fisheries**

The damage to the fisheries subsector maybe characterized as moderate, with total damage estimated at EC \$1.616 million. Of this total damage, damage is estimated at EC \$1.384 million, while loss is put at EC \$232,564.

Total damage to the aquaculture industry is estimated at EC \$1.17 million, while that for marine fishing is put at EC \$0.447 million.

Table 35 presents the details of total damage to the aquaculture industry, while damage to marine fishing is presented in table 36. With respect to the aquaculture industry, the farmer's infrastructure was significantly impacted. The impact to the union facility resulted in the loss of brood stock, as well as the seamoss industry.

Major area of damage incurred by the marine fishing industry was the loss and /or destruction of fish pots (2,255 pots). There were minor damages to boats and engines. The marine areas most impacted were Savannas Bay and Laborie (table 35).

**Table 35: Total damage to aquaculture**

LOCATION	NATURE OF DAMAGE	DAMAGE	LOSS	TOTAL DAMAGE
<b>Union facility</b>	Loss of brood stock	423,000	35,000	458,000
<b>Beausejour facility</b>	Flooding of ponds, hatchery and office building; loss of stock from ponds.	38,250	8,000	46,250
<b>Shrimp/Fish farmers(47 farmers; 110 ponds of total area 126,770 sq. ft</b>	Loss of fish/shrimp due to flooding and/or overflow of ponds. Approximately 50% of areas significantly affected. Approximately 45 ponds were with stock at the time of the disaster (95% shrimp and 5% fish). Other ponds were to receive post larvae from Union, which were lost	418,730	92,120	510,850
<b>Seamoss farmers</b>	Total loss of all lines and seamoss in water: Praslin: 120 lines Aupicon: 155 lines Canelle: 20 lines Laborie: 30 lines	82,900	12,400	95,300
<b>BUILDING</b>	Damage to Castries office.	59,250	0	59,250
<b>TOTAL</b>		1,022,130	147,520	1,169,650

Source: ECLAC estimates based on official Government of Saint Lucia data

Table 36: Total damage to fisheries - marine

Landing Site	Boat Damage		Engine Damage		Fish Pot Loss/ Destroy		Net Loss/Damage		Other	Damage	Loss	Total Damage
	No.	Cost	No.	Cost	No.	Cost	No.	Cost				
Anse La Raye					4	800				804	147	951
Banannes			1	680	10	1,200				1,891	348	2,239
Canaries			1	800						801	134	935
Castries							1	1,000		1,001	195	1,195
Choiseul					304	41,955				42,259	8,874	51,133
Dennery	3	1,600	3	2,350						3,956	727	4,683
Gros-Islet			3	2,400						2,403	505	2,908
Laborie					593	99,950			8,850	109,393	26,255	135,648
Marigot										0	0	0
Marisule										0	0	0
Micoud										0	0	0
Praslin					38	5,200				5,238	1,100	6,338
Oriver Doree										0	0	0
Roseau	2	3,500					2	23,000		26,504	5,649	36,153
Savannes Bay					1,107	142,210				143,317	35,830	183,147
Soufriere	1	9,000					1	15,000		24,002	5,280	29,286
Vieux-Fort	2	2,932	4	11,500	199	3,850			2,100	0	0	0
<b>TOTAL</b>	<b>8</b>	<b>17,032</b>	<b>12</b>	<b>17,730</b>	<b>2,255</b>	<b>295,165</b>	<b>4</b>	<b>39,000</b>	<b>10,950</b>	<b>361,569</b>	<b>85,044</b>	<b>446,613</b>

Source: ECLAC estimates based on official Government of Saint Lucia data

## (f) Forestry

The impact of Hurricane Tomas on the forest resource base of Saint Lucia may be described as severe, with the main areas of impact occurring in the Soufriere range. Observed damage to the forestry subsector maybe classified into five main categories as follows:

- (a) Damage to the forestry;
- (b) Damage to forest roads and access roads;
- (c) Damage along river banks and soil structure;
- (d) Damage to trails and related infrastructure;
- (e) Damage to wild life and habitat.

This section of the report does not take into consideration the impact of the disaster on forest roads and access roads, and river banks and soil structure which are both accounted for under the infrastructure component of the report. The nature of the damage to trails and related infrastructure are described in this section also, but accounted for under the tourism component of the report.

A summary of the impact of Tomas on the forestry subsector is presented in table 37, while further details are presented in tables 38 through 40

**Table 37: Total damage to the forestry subsector**

Category	Damage	Loss	Total Damage
<b>Plantation Forest</b>	22,269,000	1,113,450	<b>23,382,450</b>
<b>Natural Forest</b>	22,157,500	1,099,660	<b>23,257,160</b>
<b>Christmas Trees</b>	75,900	12,010	<b>87,910</b>
<b>Private Forest Stands</b>	8,875,250	443,760	<b>9,319,010</b>
<b>TOTAL</b>	<b>53,377,650</b>	<b>2,668,880</b>	<b>56,046,530</b>

Source: ECLAC estimates based on official Government of Saint Lucia data

**TABLE 38: TOTAL DAMAGE TO NATURAL FOREST BY RANGE**

Range	Hectares	No. of trees	Intensity of damage	Damage	Loss	Total Damage
Millet	25	13,330	Moderate	1,693,750	84,060	<b>1,777,810</b>
Northern	15	8,130	low	1,016,250	50,435	<b>1,066,685</b>
Quillesse	58	31,320	Moderate	3,915,000	194,300	<b>4,109,300</b>
Soufriere	200	108,000	High	13,500,000	669,995	<b>14,169,995</b>
Denney	30	16,260	Moderate	2,032,500	100,870	<b>2,133,370</b>
<b>TOTAL</b>	<b>328</b>	<b>177,040</b>		<b>22,157,500</b>	<b>1,099,660</b>	<b>23,257,160</b>

Source: ECLAC estimates based on official Government of Saint Lucia data

**Table 39: Total damage to plantation forest by range**

Range	Hectares	No. of Trees	Intensity of Damage	Damage	Loss	Total Damage
Millet	0	0	Nil	0	0	0
Northern	15	8130	Moderate	2,439,000	121,950	2,560,950
Quillesse	12	6480	Moderate	1,944,000	97,200	2,041,200
Soufriere	100	54200	High	16,260,000	813,000	17,073,000
Dennery	10	5420	low	1,626,000	81,300	1,707,300
<b>SUB-TOTAL</b>	<b>137</b>	<b>74,230</b>		<b>22,269,000</b>	<b>1,113,450</b>	<b>23,382,450</b>

Source: ECLAC estimates based on official Government of Saint Lucia data

**Table 40: Christmas tree plantation damage per range**

Range	No. of Trees	Intensity of Damage	Damage	Loss	Total Damage
Millet	0	0	0	0	0
Northern	254	Moderate	25,400	4,020	29,420
Quillesse	5	low	500	80	580
Soufriere	0	0	0	0	0
Dennery	500	high	50,000	7,910	57,910
<b>TOTAL</b>	<b>759</b>		<b>75,900</b>	<b>12,010</b>	<b>87,910</b>

Source: ECLAC estimates based on official Government of Saint Lucia data

**Table 41: Forest and trees on private lands outside reserves**

Range	Hectares	No. of Trees	Intensity of Damage	Damage	Loss	Total Damage
Millet	24	13,550	Moderate	1,693,750	84,690	1,778,440
Northern	33	17,886	Low	1,016,250	50,810	1,067,060
Quillesse	15	8,130	Moderate	1,016,250	50,810	1,067,060
Soufriere	54	29,268	High	3,658,500	182,915	3,841,415
Dennery	22	11,924	Moderate	1,490,500	74,535	1,565,035
<b>TOTAL</b>	<b>148</b>	<b>80,758</b>		<b>8,875,2400</b>	<b>443,760</b>	<b>9,319,010</b>

Source: ECLAC estimates based on official Government of Saint Lucia data

The total damage to the forestry resource base is estimated at EC \$56.047 million, with damage estimated at EC \$ 53.378 million and loss put at EC \$2.669 million. Sixty-two per cent of the total damage occurred in the Soufriere Range.

The majority of the damages in the forest were due to widespread landslides, snapped and wind thrown trees and crown damage and defoliation.

Total damage to natural forest (table 38) is estimated at EC \$23.257 million, with damage estimated at EC \$22,157 and loss EC \$2.100 million. Damage to plantation forest (table39) is estimated at EC \$23.382 million, with damage estimated at EC \$22.269 million and loss put at EC \$1.113 million.

Total damage to Christmas tree plantation was low and is estimated at EC \$87,910 (table 40 ) However, damage to forest and trees on private lands outside the reserves is estimated at EC \$9.319 million, with damage estimated at EC \$8.875 million and loss put at EC \$0.444 million (table 41).

The disturbances that occurred to the forest reserves from the passage of Hurricane Tomas was expected to create persistent increase in light gaps in the forest canopy, resulting in:

- Increased colonization and density of forest stands by pioneer species such as Bwa Cannon (*Cecropia Peltata*), mahoe cochon (*Sterculia caribaea*), Bwa laglu (*Sapium caribaeum*) and other species of low merchantable timber value, thereby, reducing the value of forest stands;
- Reduced ability for gradual transformation back to primary or climax species and the consequent reduction in biodiversity;
- Reduction in diameter classes for diversity of forest species and reduced reproduction opportunity for many species of forest trees that require a long time period for maturity and reproduction;
- Reduction in the diversity of fruiting trees and the capacity of the forest to sustain some wildlife species;
- Compromised integrity of forests' watersheds to conserve soil and water due to lack of mature trees with established roots systems and the lack of below ground roots stratification to anchor soils, increase water percolation into the soils and to sustain aquifers during the dry periods; and
- Increased forest susceptibility to the vagaries of wildfires.

Forest roads and access routes in the forest subsector suffered major damage (cost estimates included in infrastructure report), with the location of the major roads damage indicated in table 42.

**Table 42: Damage to forest and access roads**

Locations	Type of damage	Intensity of damage	Remarks
Edmund forest (6 km)	landslides	high	Restoration feasibility low. Main road through Fond St Jacques is severely damage
Barre de lisle (1 km)	Landslides and obstacle trees	low	Rehabilitation feasibility high
Forestiere (1 km)	landslides	High	Restoration feasibility very low due to two major landslides
Logging Bay/Louvette (2km)	Obstacle trees and surface erosion	low	Sustained very little damage. Restoration feasibility high
La Porte (3 KM)	Landslides Lost of bridges	high	Damage bridges due to two major landslides renders feasibility low to moderate

Source: ECLAC based on official Government of Saint Lucia data

The assessment also focused on landslides occurring along rivers, riverbanks, ware intakes and other watershed related areas. Major landslides were reported in all ranges, with most occurring in the Soufriere and Quillesse ranges.

The damage to trails and other ecotourism activities were substantial (table 43).

Table 43: Trails and other ecotourism facilities

Eco-tourism facility	Intensity of damage	Type of damages	Trail surface	Signage	Bridges	Water systems for visitor's center	Buildings	Remarks
Millet Trail (3.22 km)	Moderate	Landslides	35%	10	1	-	low	Feasibility for restoration within 6 month
Enbas Saut (3.22 km)	High	Landslides obstacle trees	80%	All signs	5	-	low	Waterfall damage affect main attraction Feasibility for restoration, indefinite
Edmond forest (3.22 Km)	High	Landslides	80%	All signs	2	high	low	Feasibility for restoration, indefinite
DesCartiers (3.22 km)	Moderate	Landslides and obstacle trees	30%	All signs	5	high	low	Feasibility for restoration, within 1 year
Union (1.6 km)	Low	Obstacle trees	10%	All signs	2	low	low	Feasibility for restoration, 1 month
Forestiere (3.22 km)	High	Landslides and obstacle trees	65%	All signs	7	high	low	Feasibility for restoration, indefinite
Barre de lisle (1.6 km)	Moderate	Landslides Surface erosion	65%	All signs	-	-	low	Feasibility for restoration, within 6 months
Hiking trail Central Forest (5.8 km)	High	Landslides , obstacle trees and surface erosion	60%	all	8	high	low	Feasibility for restoration, indefinite
Hiking trail forestiere-barre de lisle (6.7 km)	High	landslides	60%	-	-	-	-	Feasibility for restoration, indefinite
Hiking trail barre de lisle-Laport (16 km)	High	Landslides and obstacle trees	70%	All	-	-	-	Feasibility for restoration, indefinite
Hiking trail Micro reflector (6.5 km)	High	landslides	70%	all	-	high		Feasibility for restoration, indefinite

Source: ECLAC estimates based on official Government of Saint Lucia data

The impact on the wildlife in the areas that were assessed is characterized as low to moderate.

### (g) Infrastructure

Agricultural infrastructure suffered major damage. The overall estimate of the damage to the infrastructure, excluding farm roads (accounted for in general infrastructure) and livestock (including in the livestock estimates), is put at EC \$25.89 million, of which damage is estimated at EC \$7.64 million and loss at EC \$ 18.25 million.

Most of the damage to the infrastructure was in the areas of irrigation and drainage structure (EC \$23.44 million or 90.5%) and farm lands loss (EC \$1.88 million or 7.3%). Total damage to the crop infrastructure is estimated at EC \$0.57 million. See tables 30a and 30b for details.

Most of the damage occurred in Region 7 (EC \$11.11 million (42.9%).

The damage to the irrigation and drainage structure may be characterized by clogged intake resulting from heavy deposit silts, logs and debris, erosion of river banks, which in some instances compromised the rubble walls of intake chambers and also the gabian retaining structure, and the destruction of main irrigation lines (central and on-farm) and drip lines and the burying of these lines under silt.

**Table 44: Total damage to infrastructure**

Region	Damage		Sub total Damage	Loss		Subtotal Loss	Total Damage
	Irrigation	Others		Irrigation	Others		
1	649,500	77,500	727,000	3,720,600	21,100	3,741,700	4,468,700
2	15,500	35,800	51,300	12,000	7,700	19,700	71,000
3	736,200	99,500	835,700	1,259,400	25,800	1,285,200	2,120,900
4	973,500	13,300	986,800	4,795,000	2,100	4,797,100	5,783,900
5	56,000	63,100	119,100	26,200	17,900	44,100	163,200
6	26,000	52,000	78,000	18,900	12,600	31,500	109,500
7	2,725,500	95,500	2,821,000	8,267,250	24,500	8,291,750	11,112,750
8	128,600	17,500	146,100	31,400	3,200	34,600	180,700
<b>TOTAL</b>	<b>5,310,800</b>	<b>454,200</b>	<b>5,765,000</b>	<b>18,130,750</b>	<b>114,900</b>	<b>18,245,650</b>	<b>24,010,650</b>

Source: ECLAC estimates based on official Government of Saint Lucia data

**Table 45: Total damage to farmlands**

Region	Total Damage to Lands
1	42,000
2	236,600
3	393,500
4	401,100
5	56,000
6	585,900
7	380,600
8	124,500
<b>TOTAL</b>	<b>1,878,200</b>

Source: ECLAC estimates based on official Government of Saint Lucia data

#### (h) Impact of Hurricane Tomas to the agricultural sector

The total impact on the agricultural sector including forestry and fisheries, presented in table 48, is estimated at EC \$151.74 million. The damage is estimated at EC \$ 108.81 million and the losses at EC \$42.92 million.

Tables 46 and 47 presented the estimated damage and loss, respectively, to the agricultural sector by subsectors and region. The most impacted subsectors were forestry (36.9% of total damage), the banana industry (36.0%), infrastructure (17.3%) and the 'other crops' (8.0%).



**Table 46: Damage to the agricultural sector by subsector and region**

Region	Bananas	Other Crops	Livestock	Fisheries	Forestry	Infrastructure	Total Cost
1	62,154	202,750	13,150			769,000	1,047,054
2	2,058,050	38,250	86,175			287,900	2,470,375
3	9,426,601	756,950	91,195			1,229,200	11,503,946
4	12,070,002	515,550	12,955			1,387,900	13,986,407
5	6,998,801	48,150	198,130			175,100	7,420,181
6	48,789	5,622,750	55,290			663,900	6,390,729
7	4,067,733	308,600	138,810			3,201,600	7,716,743
8	2,909,875	96,320	243,060			270,600	3,519,855
OTHER				1,384,000	53,377,650		54,761,650
<b>Total</b>	<b>37,642,005</b>	<b>7,589,320</b>	<b>838,765</b>	<b>1,384,000</b>	<b>53,377,650</b>	<b>7,985,200</b>	<b>108,816,940</b>

Source: ECLAC estimates based on Government of Saint Lucia official data

**Table 47: Losses to the agricultural sector by subsector and region**

Region	Bananas	Other Crops	Livestock	Fisheries	Forestry	Infrastructure	Total Cost
1	28,134	90,900	2,525			3,741,700	3,863,259
2	931,576	15,400	27,650			19,700	994,326
3	4,266,950	454,170	26,400			1,285,200	6,032,720
4	5,463,485	283,550	2,700			4,797,100	10,546,835
5	3,168,006	21,670	64,720			44,100	3,298,496
6	22,084	3,398,560	12,350			31,500	3,464,494
7	1,841,259	212,300	32,340			8,291,750	10,377,619
8	1,317,155	50,010	48,550			34,600	1,450,315
OTHER				232,564	2,668,880		2,901,444
<b>Total</b>	<b>17,038,649</b>	<b>4,526,560</b>	<b>217,235</b>	<b>232,564</b>	<b>2,668,880</b>	<b>18,245,650</b>	<b>42,929,538</b>

Source: ECLAC estimates based on official Government of Saint Lucia data

On a regional basis, the main impacted regions were (excluding the impact on forestry and fisheries) Region 4 (16.2% of total impact), Region 7 (11.9%), Region 3 (11.6%), Region 5 (7.1%) and Region 6 (6.5%).

**Table 48: Summary table in the agricultural sector**

Total Effect	151,746
Total Damage	108,815
Bananas	37,642
Other Crops	7,589
Livestock	838
Fisheries	1,384
Forestry	53,377
Infrastructure	7,985
Total Losses	42,931
Bananas	17,039
Other Crops	4,527
Livestock	217
Fisheries	233
Forestry	2,669
Infrastructure	18,246

Source: ECLAC estimates based on official Government of Saint Lucia data

### C. TOURISM

Tourism is by any measure the single most economically significant sector in Saint Lucia. A 2009 Tourism Satellite Account prepared for Saint Lucia revealed that 64% of Saint Lucia's economic output is either directly or indirectly attributable to tourism. The core (direct only) tourism sector contributes approximately 30% to Saint Lucia's GDP, making it the top ranked sector in the economy. Preliminary figures for 2009 indicate that tourism activity injected just over EC\$1 billion into the Saint Lucia economy.

During the first 10 months of 2010 the tourism sector showed a strong recovery with stay-over arrivals increasing by 15.8% over the corresponding period of 2009. In fact the recovery was so robust that total stay-over arrivals for the year were forecasted to surpass the previous arrivals record of 317,939 in 2005. The growth in tourism predicated a slow recovery of the Saint Lucia economy event, though the other sectors showed low or negative growth rates.

According to the Saint Lucia Economic Review January – June 2010, growth was strongest in the North American market, fuelled by the introduction of low-cost airlines, expansion in the number of available seats from existing carriers and effective promotion in the United States. Strong growth was also recorded by arrivals from Europe, excluding the United Kingdom. The number of arrivals from the latter market declined. This negative result might be due to the uncertain economic recovery in the United Kingdom and by the introduction of the travel tax. The Caribbean market declined even stronger caused by weak economic performance in the region and high ticket fares, the latter exacerbated by taxation and other surcharges that can account for up to 40% of the ticket price.

**Table 49: Saint Lucia Monthly Stay-over Arrivals**

Month	2009	2010 (actual)	2010 (forecast)
Jan	23051	26083	
Feb	25262	27867	
March	25938	29580	
April	26326	26984	
May	25292	30349	
June	19706	22993	
July	26794	34186	
Aug	23304	29589	29310
Sept	14675	17393	17170
Oct	19031	20624	21124
Nov	21777		23519
Dec	27335		30070
Total	278491		
			318037
Subtotal Jan-Oct	229379	265648	

Source: Saint Lucia Tourist Board

Deep discounting, as practiced by other countries, may not have played a major role as tourism expenditures increased by 23% during the first six months of 2010 as compared with the similar period in 2009.

Like stay-over arrivals, yachting, the second major component of the Saint Lucia tourism product, showed robust growth with arrivals by yacht increasing from 19,271 during the first 6 months of 2009 to 24,915 for the corresponding period in 2010. In comparison the growth in cruise ship visitor arrivals was more modest with an increase to 605,388 arrivals during the first six months of 2010 as compared with 571,180 arrivals for the same period in 2009.

## **1. THE IMPACT OF HURRICANE TOMAS**

### **(a) Damages**

Most of the serious damages that occurred in the hotel sector were experienced in the Soufrière and in the Vieux Fort areas. Because of structural damages two hotels remain closed until the middle of December when these will partially be reopened. Total damages of the affected properties is estimated at EC \$ 67.9 million.

In the north, hotels suffered limited structural and landscaping damages during the passing of the hurricane, mostly minor roof damage and uprooted plants and trees. Many hotels, however, experienced flooding of public areas and ground floor guest rooms. Fearful of bad publicity in the marketplace, no hotel provided estimates of damages or clean-up costs, but according to the Saint Lucia Hotel and Tourism Association (SLHTA) total damages were unlikely to surpass US\$ 50,000 or EC\$ 135,000.

Neither the cruise ship terminal at Pointe Seraphine nor the marinas at Rodney Bay and Marigot Bay suffered structural damage. The planking of the jetty at the Pitons was damaged but costs are minor and are incorporated in the damages of the hotel sector.

**(b) Losses****(i) Stay-over tourism**

Given an average occupancy rate of 67%, the country did not suffer a room supply shortage in the aftermath of Hurricane Tomas. However, secondary impacts from damages particularly in the water sector, caused island-wide water supply shortages, which caused the closure of some hotels, water rationing and the purchase of water from Saint Vincent and the Grenadines as well as the transport charges for water that was made available by cruise ships.

In addition, due to the cancellation of flights and low load factors of those flights that arrived, SLASPA and the Saint Lucia Tourist Board estimate that 5199 tourists, who otherwise would have visited the island during the period of 30 October to 12 November, did not arrive.

After 12 November, the combination of the closure of a few hotels due to structural damages, and other hotels because of a lack of water resulted in an estimated loss of 19,549 room days in 2010 and of 13,080 room days in 2011. The total loss of tourism expenditures resulting from the non-arrival of 5199 tourists and the loss 19,549 and 13,080 room days for 2010 and 2011, respectively, is estimated at EC\$ 45.0 million.

The allocation of these losses in tourism expenditure over the various tourism subsectors is based on the allocation of the various spending categories of the 2009 tourism expenditure survey, as detailed in table 50.

**Table 50: Allocation of the loss of tourism expenditures over tourism sub-sectors (2010)**

Spending category	Share in total spending	Allocated Losses (EC\$ 000's)
Accommodation	0.72	32232
Food and Beverage	0.06	2493
Transportation	0.04	1608
Shopping	0.07	3172
Entertainment	0.03	1273
Tours	0.06	2742
Other	0.03	1463

Source: ECLAC estimates based on Saint Lucia Tourist Board data

Apart from the losses in tourism expenditure, there were increased costs for cleaning up and debris removal, the purchase of water and the cost of the shuttle between the Hewanorra and the George F.L. Charles airports.

None of the members of the SLHTA submitted cost estimates for cleaning costs or for debris removal, hence, such estimates are not included in the assessment. However, on many occasions, in common with other Caribbean countries, establishments used staff for clean up.

Following the passage of the hurricane and the resultant lack of supply of water the SLHTA arranged for a supply of water from three different cruise ships for a total supply of 190,000 gallons. Hotels also made arrangements for the importation of water from Saint Vincent and the Grenadines. A total of 10 shipments of 35,000 gallons each were recorded. Details are presented in table 51.

**Table 51: Emergency water supplies and costs**

Source	Quantity in gallons	Additional cost per gallon over WASCO water cost	Total cost (EC \$)
Barged from SVG	350000	43	150500
from Cruise ships	190000	13	24700
Subtotal	540000		175200

Source: ECLAC estimates based on submissions from SLASPA and the SLHTA

Following the hurricane, road connections between the north of Saint Lucia and the long haul airport of Hewanorra, were impeded. To facilitate the movement of extraregional passengers, a shuttle was established between the George F L Charles and Hewanorra airports. Eighty five per cent of the cost was allocated to tourism with the remainder being allocated to Saint Lucia residents. See table 52.

**Table 52: Airport shuttles between George F L Charles and Hewanorra (and vice versa)**

	Pax	Cost/flight US	Cost
LIAT	477	50	23850
	134	50	6700
CARICOM Airways	49	100	4900
	46	100	4600
Subtotal US\$			40050
Subtotal EC \$			108135

Source: ECLAC estimates based on data supplied by SLASPA

### (ii) Cruise ships

Seven cruise ship visits were cancelled with a total complement of 11,917 passengers. Following the Florida Caribbean Cruise Association (FCCA) 2009 survey results, 80% of these are assumed to disembark in Saint Lucia. In addition, 5083 crew were on board, of whom 40% went on shore. Average expenditures amounted to US\$ 68.53 and US\$ 37.66 for cruise ship visitors and crew, respectively. Therefore, total losses, including the levy of EC\$ 6.50, amounts to EC \$ 2.0 million. The foregoing estimate excludes port dues and navigation charges.

### (iii) Yachting

While there were no damages in the main marinas of Rodney Bay and Marigot Bay and no major losses are expected in those two marinas, the Soufriere Marine Management Area (SMMA) is expected to experience a loss in yacht arrivals. Preliminary estimates reveal that bookings for the winter season are down by 20% - 40%. For November 2010 visits stood at about three yachts per day as compared with November 2009 when it stood at about eight yachts per day. It is estimated that in 2010 the SMMA will lose 300 yacht nights and 700 yacht nights in 2011. Many of these will be yachts from Martinique that are 'en route' to the Grenadines and which will now bypass Saint Lucia altogether. It is assumed that the proportion of such yachts amounts to 50%. The losses incurred by the SMMA and Soufriere (the other 50%), which will stay in other parts of Saint Lucia, are not losses to Saint Lucia because presumably

these losses will be offset by expenditures in the other parts of the country. Therefore, yachting losses will amount to EC\$ 48,000 for 2010 and EC\$ 111,000 in 2011.

#### **4. ENVIRONMENT**

The passage of Hurricane Tomas had severe environmental consequences on the marine and terrestrial environment of Saint Lucia. While wind and storm surge damages were minor, the impacts caused by landslides and flooding were major and its effects will continue to be felt as long as the numerous landslides have not stabilized.

A rapid assessment by the Forestry Department suggests that the dry forest areas on the east coast of Saint Lucia and the offshore islands had low impacts because landslips were relatively uncommon. Areas with low to moderate impacts included the Government Forest Reserve and the Piton Management Area. Within these areas, localized impacts could be severe, mostly due to landslips. The initial assessment of wildlife and habitats concluded that impacts on local wildlife was low to moderate although habitat loss in severely affected areas or for selected species could have resulted in localized areas of stress. In addition, the ability to manage sites and priority species have been impacted by Tomas by limiting access to the habitats. This is most notable in the Government Forest Reserve and the Piton Management Area sites.

The mass movement of soils and flooding has resulted in extensive siltation of the marine and coastal environments, particularly in the Soufriere area. This is evidenced by the large plumes of brown silted waters and floating debris in many bays and along the coast. Materials deposited in the sea include large volumes of solid and liquid waste, fine to heavy particulate materials and organic debris. Silt resulting from the landslides in the Soufriere areas were expected to be transported through ocean currents to the coral reef reserves of the SMMA and the CAMMA. The SMMA has reported significant layers, up to two inches thick, of sediments on the coral reefs. Because of the unsettled nature of the landslips, it is anticipated that this siltation will continue until the soil masses have stabilized.

#### **1. ATTRACTIONS AND FORESTS**

Following the hurricane there were reported damages to several Ministry of Tourism attractions, especially sites in and around the Soufriere area, managed under the umbrella of the Saint Lucia Heritage Tourism Association (Heritas) and the Soufriere Regional Development Foundation (SRDF) and the trails maintained by the Department of Forestry. See table 54.

Damages to attractions were especially for the Forestry Department as 54.2 km. of forest trails were damaged or destroyed. Of these, the Union trail was expected to be restored by December, the Millet and Barre de Lisle trails were expected to be in operation within six months and DesCartier within a year. The feasibility of restoring the remaining 44.6 km. of trails was considered to be low and new trails would have to be developed. In addition, 12 km. of forestry access roads had also suffered damage. Damages to roads and trails are accounted for under infrastructure.

Other damages in the forestry sector concern the damage to trees, which are accounted for under agriculture. The majority of such damages were caused by the mass movement of soils and, sporadically in Quillesse and the Northern range, by wind.

The Sulphur Springs suffered damages to the extent of EC\$ 122,000 and the Saint Lucia National Trust had only minor damages (see table 53). No information was obtained from the other attractions.

**Table 53: Damages to Attractions and forests  
(EC \$ million)**

	<b>Length (km)</b>	<b>Area (ha.)</b>	<b>Damages</b>
Forest trails	54.2		8.2
Natural forest		320	22.2
Plantation forest		137	22.3
Private lands		148	8.9
Sulphur Springs			0.1
<b>Total</b>	<b>54.2</b>	<b>605</b>	<b>61.6</b>

Source: ECLAC based on mission estimates

By the middle of November the attractions managed by the SRDF, such as the Sulphur Springs and the Tet Paul nature trail at the Pitons World Heritage Site, had reopened. However, the closure of hotels in the Soufriere area and the drop in yachting arrivals at the SMMA will have repercussions on the gross income of the SRDF in 2010 and 2011.

Losses in the form of lost income from visitor arrivals, caused by the shortfall in the number of (projected) tourist arrivals have been accounted for in the tourism section. However, there will be other losses of income, because attractions, such as the Forestry trails, are not as yet accessible. It is assumed that visitors will substitute such anticipated expenses for other expenditure categories at no net loss to the Saint Lucia economy.

Forestry derives a fee of 10% of the cost of forest tours. The annual income to the Forestry Department is about EC \$ 150,000 per year, implying an annual income of forest attractions of about EC\$ 1.5 million. Until new forest trails are established this income must be considered as lost.

Turbidity and the high levels of sedimentation on the coral reefs may affect the health of the reefs that have already been weakened by previous hurricanes, white band disease, and anthropogenic pollution. It is anticipated that this will negatively affect fisheries and dive tourism in the near and medium term. Data, however, was not available, to analyze these impacts.

**Table 54: Losses to attractions  
(EC \$ 000's)**

	<b>2010</b>	<b>2011</b>
Forestry trails and tours	250	1,250
Sulphur Springs	185	
Heritas sites	nd	nd
Lost fisheries and dive tourism earnings	nd	nd
<b>Total</b>	<b>435</b>	<b>1,250</b>

Source: ECLAC base on mission estimates

## **2. DEBRIS**

The landslides and flooding caused large amounts of debris that had to be cleared. Charges for debris removal are included in the respective sectors, but the table below provides an overview of the identified estimated losses that stem from the removal of debris, see table 55.

**Table 55: Losses due to the removal of debris.  
(EC \$ millions)**

<b>Loss of forest trees</b>	<b>53.4</b>
<b>Debris removal</b>	<b>39.7</b>
<b>De silting of John Compton Dam</b>	<b>51.9</b>
<b>De silting rivers and slope stabilization</b>	<b>43.2</b>

Source: ECLAC based on mission estimates

The total of EC \$ 40.2 million relates to the immediate clean-up efforts, which are still ongoing, in the aftermath of the hurricane. However, because of the unconsolidated landslides that will deposit additional debris on the roads, additional mobilization of resources, particularly for Public Works and the Castries and Soufriere City Councils, will remain necessary and allowances for the allocation of additional budgetary funds will need to be made.

### 3. SUMMARY

Table 56 shows the summary data of the damages and losses incurred by the tourism sector as a consequence of the passage of Hurricane Tomas.

**Table 56: Summary of damages and losses in tourism**

<b>EC \$ 000's</b>	<b>2010</b>	<b>2011</b>
Total Impact	115,263	4,106
Damages	67,933	
Stay-over tourism	67,933	
Yachting sector	0	
Cruise ships	0	
Losses	47,330	4,217
Hotels	45,250	4,106
Yachting	48	111
Cruise ships	2,033	0

Source: ECLAC based on Government of Saint Lucia data.

### 4. CONCLUSIONS

The tourism infrastructure withstood the hurricane, but it was the damages to the superstructure, i.e. the road network and, above all, the supply of water, that caused a drop in demand, hotel closures and an atmosphere of uncertainty in the market place. This uncertainty has resulted in a drop in forward bookings from the United Kingdom and continental Europe, but less so from the United States.

The sector has become particularly vulnerable to shortages in the water supply. Ironically, during the drought during the earlier part of the year the sector was also suffering from water shortages.

There were weaknesses in the tourism crisis management plan which, perhaps, paid less attention to business continuity and the market place.



#### D. THE IMPACT ON THE MANUFACTURING AND DISTRIBUTION SECTORS

The manufacturing and distribution sectors are important contributors to value added in the Saint Lucian economy. An important component of distribution is related to tourism-based activities and this is underscored in the large contribution of tourism (including multiplier effects) to total GDP. Nevertheless, manufacturing and distribution, in their own right, remain important contributors to income and employment. During the last five years, manufacturing and distribution contributed 10.7% to GDP on average. The average contribution of manufacturing was 7.1%, while distribution contributed 14.4%.

A profile of the manufacturing and distribution sectors reveal that there are mainly comprised of a number of small and micro-businesses, interspersed with few large businesses. The private sector baseline study of 2009, considers an establishment employing five or more persons as formal. The survey found that there were 2,408 enterprises in the distribution sector in 2009, 1,400 of which were registered and 1,008 unregistered. Across all sectors, distribution is the leading sector by number of enterprises. Meanwhile, there were 645 manufacturing enterprises, 367 of which were registered and the balance unregistered.

The office of Private Sector Relations conducted a survey of businesses to ascertain the damage and losses that they suffered as a result of the hurricane. The survey returned 48 valid responses, made up of 23 manufacturing and 25 commercial businesses and with 5 responses missing. Moreover, the survey was fairly representative of the business sector, with participants ranging from the food and beverage sector, to larger and smaller manufacturers to variety stores, among others.

Based on the survey, damage to the manufacturing sector was conservatively estimated at EC\$11.9 million, made up of damage to stocks EC\$6.5 million, damage to machinery and equipment EC\$5.4 million and lost production and clean up costs EC\$5 million and EC\$1.3 million, respectively, (see table 57). A number of manufacturing establishments in the worst affected areas including, Vieux-fort and Bexon, suffered significant flood damage resulting in damage to plant and equipment, loss of supplies and disruption of sales. In addition, the water shortage stemming from damage to the Roseau Dam, contributed to varying loss of production days in some establishments.

**Table 57: The Impact of Hurricane Tomas on the Manufacturing Sector (EC\$ millions)**

Component	Total damage and losses	Damage	Losses
Damage to Machinery & Equipment	5.4	5.4	
Damage to Stocks	6.5	6.5	
lost production	5		5
Cleanup costs	1.3		1.3
<b>Total</b>	<b>18.2</b>	<b>11.9</b>	<b>6.3</b>

ECLAC: Based on data from the Office of Private Sector Relations Survey

The total impact on the distribution sector was estimated at EC\$22.9 million, as detailed in table 58, comprising damage of EC\$12.3 million and losses EC\$10.6 million. The most important sub-component was loss of sales of EC\$10.6 million, arising from flood damage to businesses, water supply difficulties and reduced consumer demand. Damage to machinery and equipment was estimated at EC\$6.7 million, while damage to stocks amounted to EC\$3.2 million. This occasioned shortages of some food items in the worst affected communities. Meanwhile, cleanup costs were estimated at EC\$2.4 million.

**Table 58: The Impact of Hurricane Tomas on the Distribution Sector (EC\$ millions)**

<b>Components</b>	<b>Total damage and losses</b>	<b>Damage</b>	<b>Losses</b>
Damage to Machinery & Equipment	6.7	6.7	
Damage to Stocks	3.2	3.2	
loss of sales	10.6		10.6
Cleanup costs	2.4	2.4	
<b>Total</b>	<b>22.9</b>	<b>12.3</b>	<b>10.6</b>

ECLAC: Based on data from the Office of Private Sector Relations Survey

Apart from the monetary costs of the impact on the manufacturing and distribution sectors, however, the livelihoods of affected persons would be severely impacted, as a number of operators lost their means of production, including motors, generators, refrigerators and processing equipment that would disrupt their production and sales until replaced.

## **E. SOCIAL SECTOR**

### **1. HOUSING**

The level of damage to the housing stock from Hurricane Tomas, of 3.5%, was just over three times the damage to the housing stock caused by Hurricane Dean in 2007, which damaged a little less than 1% of the stock. Table 59 details the number of affected households and the proportion of affected households by District. In all, some 1,860 households were damaged and destroyed, with destroyed houses accounting for 248 or 13% of those affected. The largest number of damaged and destroyed houses occurred in suburban/rural Castries, with 253 houses affected, followed by Soufriere which had the next largest absolute number of houses affected, 308, and Micoud ranked third, with 284 houses affected. The District of Soufriere may have felt the effect on their housing stock more severely, than other districts as their loss accounted for 12% of their houses.

All reports of damage or destruction were not yet in at the time of compilation of the report so this may be an underestimation.

**Table 59: Damaged and destroyed houses by District**

Districts	Total number of households	Total Number of Houses Destroyed and Damaged	Proportion of Houses destroyed and damaged	Number of Houses Destroyed
Total Saint Lucia	53,866	1860	3.5%	<b>248</b>
Castries Metro	617	0	0.0%	0
Castries suburban/rural	21445	534	2.5%	79
Anse La Raye	2,076	86	4.1%	4
Canaries	631	24	3.8%	2
Soufriere	2,557	308	12.0%	21
Choisuel	2,024	92	4.5%	22
Laborie	2,443	116	4.7%	26
Vieu-Fort	5,343	173	3.2%	31
Micoud	5,350	284	5.3%	40
Dennery	4,327	118	2.7%	12
Gros-Ilet	7,054	125	1.8%	11

Source: ECLAC estimates based on Saint Lucia Population Data 2010 and official Government of Saint Lucia data

It is important to note that houses which were damaged or destroyed, as a result of Hurricane Tomas, were not necessarily among the poorest households in the Districts. Map 2 which displays the damage caused by Hurricane Tomas to the housing sector as an overlay of the distribution of poverty in Saint Lucia, illustrates that most of the houses would have been found among the low to middle income communities and not among the poorest.

This, of course, has implications for value of damage to the affected home owners. In addition data from the 2010 Census, as presented in table 60, suggests that in all three most affected communities more than 70% of the dwellers, and in the case of Marc, 85%, owned their homes. However, there were very few homeowners who had insurance coverage. Insurance coverage was as low as 12% in the case of Fond St. Jacque, 10% in Bexon and 7% in Marc. Small proportions of dwellers rented properties but the loss of rental income will impact significantly on the already hard hit home owners.

**Table 60: Selected Characteristics of Dwellers by Communities<sup>18</sup>**

Communities	% that have house insurance	Home owned Fully	Land owned Fully/Freehold	Rented
Fond St Jacque	12.1%	73.70%	43.80%	13.3%
Bexon	10.0%	80.40%	80.40%	9.8%
Marc	7.0%	85.8%	42.90%	6.4%

Source: Specially prepared data from the 2010 Census, Government of Saint Lucia Statistics Office

<sup>18</sup> This data is very preliminary and have not been weighted to reflect Census refusals and no contacts and to compensate for census coverage errors which could be in the region of 10%.

In addition to private home owners, the government housing sector also received a hard blow. The government had undertaken the development of a housing project for the relocation of low to middle income households. The site, known as Barons Drive Relocation Project, Cresslands, suffered significant damage to infrastructure such as road, drains, and the erosion of two building lots. There was full collapse of one completed housing unit and minor damage was suffered to at least six completed housing units. Damage was also suffered to two units which were under construction. In its initial report, the Ministry of Housing concluded that Hurricane Tomas had left the site almost completely covered in mud, soil, boulders, trees and other debris. Table 61 sets out the percentage of damage suffered to government infrastructure and housing at the site.

The damage to the site amounted to EC\$ 2.1 million or 60% of the original cost of construction for the infrastructure and EC\$0.787 or 40% of the cost of the housing units.

**Table 61: Barons drive relocation project, Cresslands Value of damage to the project**

<b>Component</b>	<b>Original cost</b>	<b>Percentage damaged</b>	<b>Value of damage</b>
Infrastructure	3,503,443.00	60%	<b>2,102,066</b>
Housing units	1,969,640.00	40%	<b>787,856</b>
<b>Total</b>	<b>5,473,083.00</b>		<b>2,889,922</b>

Source: ECLAC estimates based on Government of Saint Lucia official data

Map 6: Damage Households by Poverty

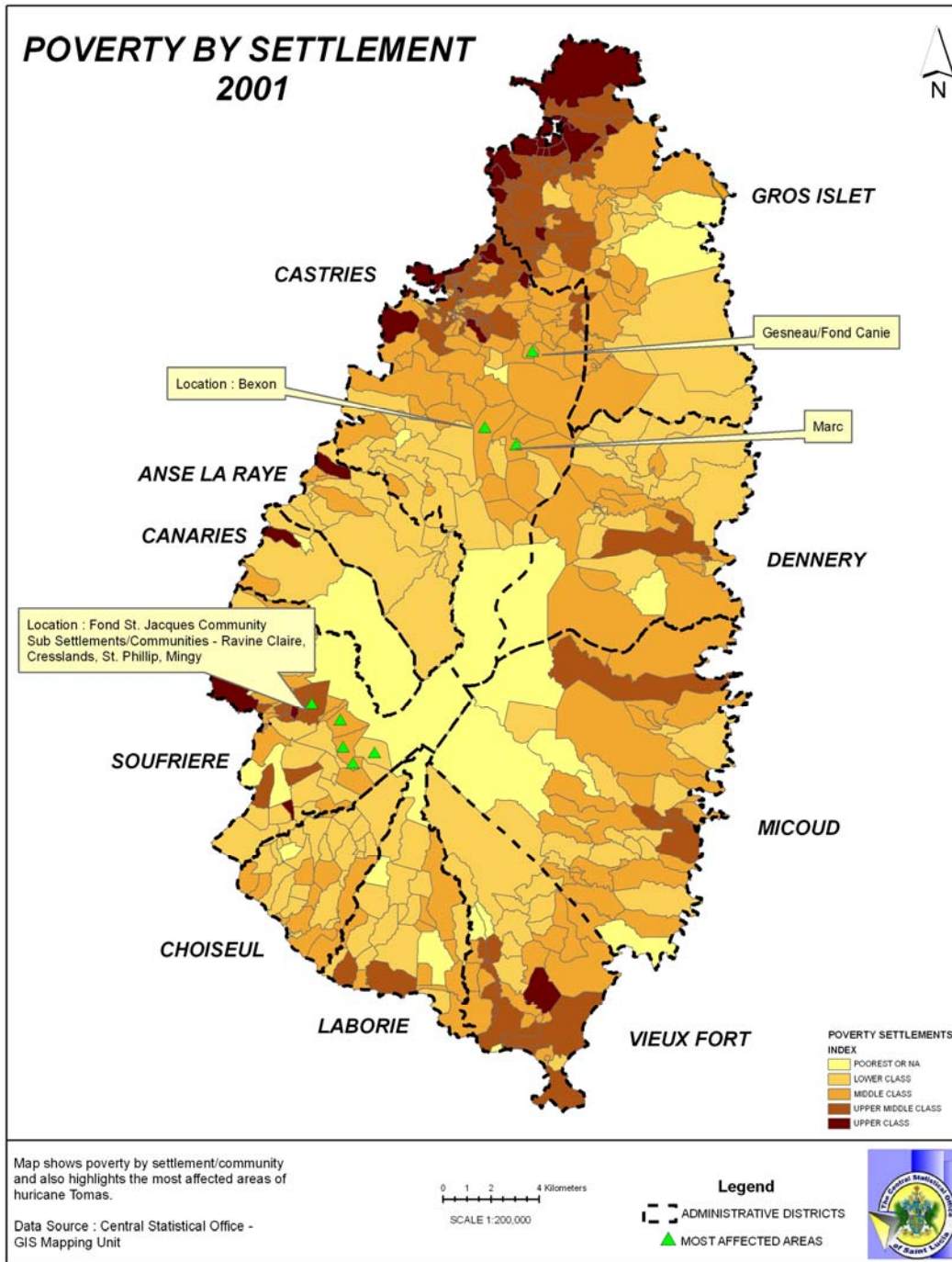

The total effect on the housing subsector is EC\$192 million as presented in table 62. The damage, EC\$ 182 million, accounts for 95% of the total effect while the losses, EC\$9.5 million, accounts for the remaining 5%. The import component is significant in the housing sector as it accounts for some 70% to 75% of total cost of construction. The largest component of the losses arises from the cost of the removal of debris which amounts to EC\$9.2 million.

**Table 62: Saint Lucia: Summary table of damage and losses for housing subsector**

<b>Total Effect</b>	<b>192,039,066</b>
<b>Damage</b>	<b>182,538,380</b>
i. Value of Houses Damaged	109,311,456
ii. Value of Houses Destroyed	47,526,720
iii. Value of Furnishings affected	25,700,204
Import component <sup>19</sup>	136,903,785
<b>Losses</b>	<b>9,500,686</b>
i. Value of lost income from rental properties	240,686
ii. Cost for removal of debris	9,260,000

Source: ECLAC estimates based on official Government of Saint Lucia data

## 2. HEALTH

The health sector suffered a serious blow to its delivery of services in the south western part of the island with damage to the physical plant causing the decommissioning of the Hospital in Dennery and damage to the road infrastructure surrounding the Soufriere Hospital, which made access to the facility near impossible. In the northwest, the Polyclinic at Gros Islet was compromised and, so, could not be used. In its preliminary report, the ministry concluded that damage to road networks, medical facilities and the water supply, severely affected health service delivery in the period following Hurricane Tomas.

Primary curative and preventive care in the public sector is provided by a network of 33 health centers, 2 district hospitals and a polyclinic. Table 63 presents details on damage to facilities in eight of the nine health regions of the country. Map 7 sets out the health regions.

<sup>19</sup> National report on Housing and Resettlement in Saint Lucia, prepared by Engineering Construction and Management Consulting (ECMC) Ltd. April 2007. The report indicated that from the data collected it could be suggested that average imports could amount to approximately 70 to 75 percent of the total cost of construction.

**Table 63: Health facilities damaged and destroyed by Hurricane Tomas by health regions**

Region	Name of Region	Population Served	%of total population serviced	Description of damage to facilities	Cost of damage to facilities
1	Gros Islet	13,033	8	Roof of small theatre in Gros Islet Poly clinic was compromised. Clinic was operable;	2,950.00
2	Babonneau	7,110	5	No fundamental damage	...
3	Dennery	13,351	8	The Dennery facility has been rendered inoperable and is out of commission. It suffered damage to roof and flooding.	4,914,818.62
4	Micoud	15,758	10	Micoud Health Centre Internal flooding	3,460.00
5	Vieux Fort	27,092	17	The facility at Vieux Fort is in operational condition, however, it suffered flooding and has no running water due to lack of storage facility;	
				The Laborie health Centre has damage to its fence	30,000
6	Soufriere	19,034	12	Soufriere Hospital badly leaking – damage to roof	314,000.00
				Etang health Centre badly leaking roof	91,352.00
7	Anse La Raye	10,957	7	Jacmel health centre damage to roof	76,352.00
8	Castries	52,788	33	Victoria Hospital suffered a heavily leaking Paediatric Ward; X-ray department was heavily flooded; Mental Wellness Centre is blocked by fallen wall; Entrepot Health Centre damage to roof	192,000.00
				Ti Rocher Health Centre flooding due to damaged drains and blockage to guttering	17,325
<b>Total damage and destroyed</b>					<b>5,642,257.62</b>

Source: ECLAC estimates based on official Government of Saint Lucia data

The cost of damage to the affected Polyclinic in Gros Islet amounts to approximately EC\$2,950. The Dennery Hospital, which accounts for some EC\$ 4.9 million, the Soufriere Hospital, EC\$ 0.314 and the Victoria Hospital, EC\$ 0.192, would comprise the largest portion of all the reported damage to health facilities.

Costs of relocation of the Dennery Hospital amount to EC\$0.863 million and are detailed in table 64. The Ministry of Health hopes to reduce the costs that would have to be incurred by such an undertaking through the salvaging of materials and equipment from the Dennery Hospital.

**Table 64: Costs of relocation of the Dennery Hospital**

<b>Cost of Relocation of Dennery Hospital</b>	
Rental of new facilities - for approximately 18 months	54,000
Refurbishment of said location to make it suitable for hospital	479,500
Removal of salvageable materials from old hospital	10,000
Purchase of replacement materials ( not salvageable)	300,000
Installation costs	20,000
<b>Total</b>	<b>863,500</b>

Source: ECLAC estimates based on GOSL official data

The total effect on the health sector, amounted to EC\$ 8.3 million as presented in table 65. This represents some 4% of the total effect to the social sector.

Damage accounted for EC\$6.4 million or 77% of the total effect, while losses, which amounted to EC\$ 1.9 million or 23% of the value of the total effect, were primarily incurred through the relocation of the Dennery Hospital. This relocation accounted for 46% of the losses while the removal of debris from the health facilities, which accounted for EC\$0.810, accounted for the other largest share of 43%. Increased public health services and medical supplies and lost income accounted for the remaining 8% of the value.

**Table 65: Saint Lucia: Summary table damage and losses for health sector**

<b>Total Effect</b>	8,288,894
<b>Damage</b>	6,417,507
i. Value of Damaged Health facilities	724,489
ii. Value of Destroyed Health facilities	4,914,818
iii. Value of Equipment damaged and destroyed	<b>778,200</b>
<b>Import component</b>	4,813,130
<b>Losses</b>	1,871,387
i. Value of lost income from increased Public health Services	139,298
ii. Cost of increased medical supplies	5,557
iii. Lost income due to services which could not be provided	53,032
iii. Cost for removal of debris	810,000
IV. Value of relocation of Hospital	863,500

Source: ECLAC estimates based on official Government of Saint Lucia data

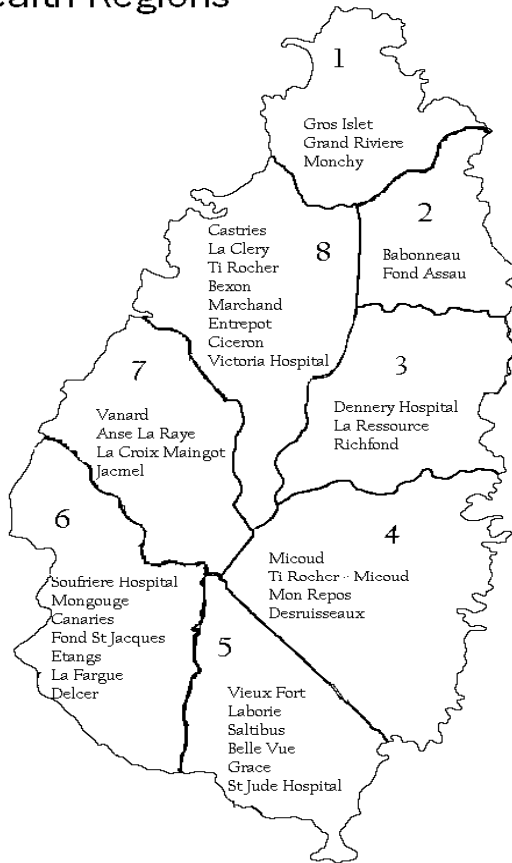

**Map 7: Health regions****Health Regions****Health regions:**

No. 7: La Guerre to be added

No. 8: Marchand to be deleted

**3. EDUCATION**

The Ministry of Education reported that no school was spared the fury of Hurricane Tomas. Table 66 presents the number of schools by level of education and those that suffered the effects of Hurricane Tomas. Nearly two thirds of all schools on the island, or 63 out of 100 schools, suffered significant damage to necessitate clean up and repairs, beyond that which could be handled by the usual clean up crews. Of the secondary schools, 17 or 71% were affected and among the primary, 45 or 60% were affected by the extreme event.

Schools remained closed for more than three weeks and unfortunately had to be closed again just as they were to be reopened for two days on (18-19 November) due to heavy rainfall which caused more disruption and damage.

**Table 66: Number of schools damaged by level of institutions**

<b>Level of institution</b>	<b>Number of existing schools</b>	<b>Number of schools suffering damage</b>
Primary	75	45
Secondary	24	17
Tertiary	1	1
Totals	100	63

Source: ECLAC estimates based on official Government of Saint Lucia data

Table 67 presents the description and value of the damage to selected schools at the secondary level. School stock on the island can be as old as 25 years in some instances and many suffered severe damage. Such destruction occurred to roofs, ceilings, and electrical fittings. Those schools that were located in areas which experienced severe flooding, such as Bexon Primary, suffered from the ravages of the flood waters with the resultant heavy siltation. Landslides and fallen trees also affected schools. Land slippage has left some schools precariously perched on hillsides or near river banks, requiring retaining walls.

The result of such widespread flooding was that school furniture, desks and shelving, teaching materials, computers and school supplies were destroyed. The Ministry of Education reported that schools in every educational district sustained some degree if not complete loss of furniture, equipment and appliances. Table 68 presents the details of furniture which were lost as a result of Hurricane Tomas.

**Table 67: Secondary schools damaged with description of damage and cost**

<b>Secondary schools</b>	<b>Description of damage</b>	<b>Cost</b>
Castries Comprehensive	Waterlogged classrooms from driving rain and leaking roofs; General cleaning and repairs to concrete roof	165,000.00
Clendon Mason Memorial	Damaged roof sections: Remove and replace damaged metal rafters and galvanize sheets	106,000.00
Choiseul Secondary	Damaged ceilings in blocks A&B, windows and leaks in staffroom	42,000.00
Corinth Secondary	Section of roof compromised; Undertake repairs to roof	25,000.00
St. Mary's College	Damage to roof; Repair Roof	20,000.00
Soufriere Comprehensive	Extensive concrete roof leaks ; Damage windows, doors, toilets, and general plumbing	83,000.00
Entrepot Secondary	Water damage in classrooms and staffroom due to damaged sections of roof; Roof to be repaired and ceiling to be replaced in damaged sections	60,000.00
St. Joseph's Convent	Land slippage; Clear slide, construct retaining wall	200,000.00
Bocage Secondary	Galvanize roofing to Block E completely removed; Roof covering to be replaced	60,000.00
George Charles Secondary	Heavy deposit of mud and debris on access road due to flooding; clearing of road to provide access to school property	50,000.00
Playe Secondary	General damage to building, fence; Undertake repairs and general cleaning	62,000.00
Vieux Fort Comprehensive (Campus A)	Damage to roof over walkway; Undertake repairs to roof	60,000.00
Vieux Fort Comprehensive Campus B	Demolished wooden cottage, fencing, doors /windows and roof; Undertake repairs to roof, ceilings, fencing, doors and windows	195,000.00
Babonneau Secondary	Water seepage to class rooms; General cleaning; land slippage-clearing of debris and construction of Gabion retaining walls	260,000.00
Vieux Fort Technical Secondary	Damaged roof sections; Undertake repairs to roof	8,600.00
Cicéron Secondary	Land slippage to rear of building; Clear debris and reinforce wall barrier; flooded classroom	100,000.00
Marigot Secondary	Land Slippage to rear of building; General clearing of debris and construction of wall barrier; reinstatement of railings	170,000.00
<b>Total Schools damaged</b>		<b>1,666,600.00</b>

Source: ECLAC estimates based on official Government of Saint Lucia data

**Table 68: Total number of damaged/destroyed furniture items for the Schools System**

<b>Student Desks</b>	<b>Student Chairs</b>	<b>Teachers Desks</b>	<b>Teachers Chairs</b>	<b>Black Boards</b>	<b>Book Shelves/ Cupboards</b>	<b>Filing Cabinets</b>	<b>Lunch Tables</b>	<b>Principals Chairs</b>	<b>Sofa Chair</b>	<b>Folding Tables</b>
1,435	1,330	105	143	38	196	17	45	5	2	5

Source: ECLAC estimates based on official Government of Saint Lucia data

The closure of schools has also had a negative effect on the Schools' Feeding Programme, on which many children depended to supplement their basic food needs. The Poverty Assessment Report of 2005/06 reported that there were significant children among the poor who did not get enough to eat and others who were always hungry.

Figure 13 illustrates the distribution of damage experienced at the different levels of the education system. Damage to the primary level within the education sector accounted for some 51% of all damage assessed, at the secondary level accounting for 40% and the tertiary level accounting for 9%.

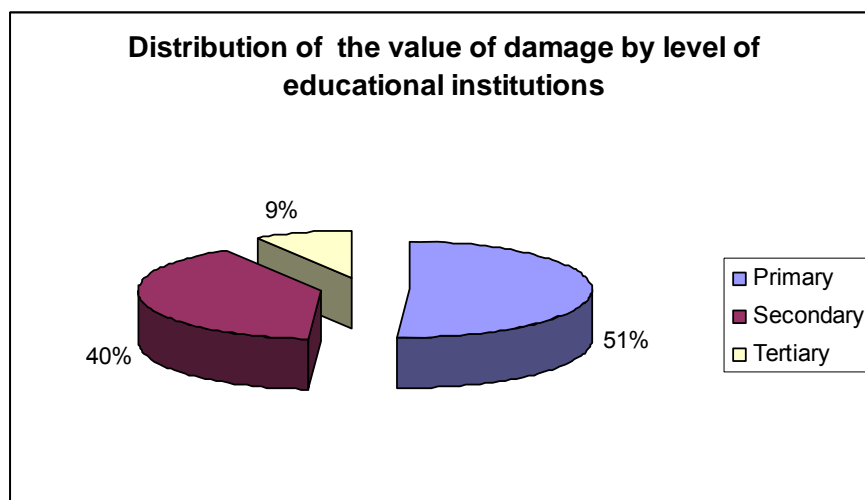
**Figure 13: Distribution of damage by level of educational institutions**

Source: ECLAC estimates based on official Government of Saint Lucia data

The total effect on the education sector which is detailed in table 69, amounted to EC\$ 8.8 million. The damage accounted for EC\$ 7.1 million or 81% of the overall effect with the remaining EC\$ 1.7 million in losses, accounting for the remaining 19%.

The largest share of the damage, EC\$4.2 million, or 59%, was as a result of damage to educational facilities with damage to school furnishings accounting for EC\$ 2.38 million or 33.4%, with damage to the one tertiary level institution on the island, the John Compton Community/College and sporting facilities accounting for 4.9 % and 2.8%, respectively.

It should be noted that data on sporting facilities in communities were not available at the time of the evaluation. This date would increase the value of the overall effect as there might have been damage to grounds and, therefore, cleaning costs would need to be identified.

**Table 69: Saint Lucia: Summary table damage and losses for the education sector**

<b>Total Effect</b>	<b>8,864,254.00</b>
<b>Damage</b>	<b>7,139,654.00</b>
i. Value of Educational facilities Damaged	4,212,600
ii. Value of furnishings affected	2,385,054
iii. Value of Sporting facilities damaged	191,000
iv. Value of damage to tertiary level institution	351,000
Import component	5,354,740.50
<b>Losses</b>	<b>1,724,600.00</b>
i. Cost for removal of debris	1,724,600.00

Source: ECLAC estimates based on official Government of Saint Lucia data

## **IV. THE MACROECONOMIC IMPACT OF HURRICANE TOMAS ON SAINT LUCIA**

### **A. SUMMARY OF IMPACT**

The combination of the nature of the event and type of environmental vulnerability in Saint Lucia has made Hurricane Tomas an important capital stock event. The capital infrastructure of the island, including roads and bridges, has been severely damaged. The total cost of the damage and losses to the different sectors amounted to EC\$907.7 million or US\$336.2 million. The scale of the event can be gleaned from comparing the total impact with key economic indicators. The total impact represents 43.4% of GDP, nine times agricultural GDP, three times tourism GDP, 62% of exports of goods and services, 19% of gross domestic investment and 47% of public external debt.

Hurricane Tomas was primarily a damage event and, as such, this, combined with the fact that it took place late in the year, will help to contain the fall-out in GDP. Damage to capital assets and stock comprised 67% of the total impact, with losses that affect value added accounting for the balance.

The profile of the impact indicate that the infrastructure sector was the most heavily affected, representing 43% of the total impact, however, the productive sectors and social sectors also suffered significant impact. Within the infrastructure sector, the water supply and water disposal systems were severely disrupted with heavy siltation of the main Roseau Dam. As a result, the cost to the water supply, disposal and works subsector is estimated at EC\$124.47 million, representing 32% of the fall-out in the infrastructure sector and 14% of the total impact. The diversion and silation of main rivers will also incur substantial costs in river training and desilting. Major damage and destruction to the transport network (roads and bridges), including forest roads, conservatively estimated at EC\$141.7 million (15.6% of the total impact), is an important cause for concern as it would entail substantial costs to rebuild them to an upgraded standard to withstand an event of a reasonable magnitude. Fortunately, the impact on the telecommunications sector was contained to EC\$10 million. Similarly damage and losses in the electricity subsector were relatively modest at EC\$8.3 million, limiting the disruption to business and the lives of persons from this sector.

The productive sectors suffered important disruption that would affect the growth in real output in 2010, but with limited carry-over into 2011. The total impact on the sector amounted to EC\$306.8 million (34% of the total). The mainstay tourism sector suffered the brunt of the effects on the productive sectors, amounting to EC\$114 million, fully 37% of the impact on the sector.

Table 70: Summary Damage and Losses from Hurricane Tomas on Saint Lucia

	Total Impact US\$ millions	Total Impact EC\$ millions	Damage	Losses	% of Total Impact
Exchange rate to US dollar	2.7				
<b>Total</b>	<b>336.16</b>	<b>907.62</b>	<b>607.92</b>	<b>299.7</b>	
<b>Productive sectors</b>	<b>113.64</b>	<b>306.84</b>	<b>200.94</b>	<b>105.9</b>	<b>33.8</b>
Agriculture	56.21	151.78	108.84	42.94	16.7
Bananas	20.25	54.68	37.64	17.04	6.0
Other Crops	4.49	12.12	7.59	4.53	1.3
Livestock	0.39	1.06	0.84	0.22	0.1
Fishing	0.60	1.61	1.38	0.23	0.2
Forestry	20.77	56.07	53.4	2.67	6.2
Infrastructure	9.72	26.24	7.99	18.25	2.9
Tourism	42.21	113.96	67.9	46.06	12.6
Manufacturing	6.74	18.2	11.9	6.3	2.0
Distribution	8.48	22.9	12.3	10.6	2.5
					0.0
<b>Social Sectors</b>	<b>77.48</b>	<b>209.19</b>	<b>196.1</b>	<b>13.09</b>	<b>23.0</b>
Housing	71.13	192.04	182.54	9.5	21.2
Education and culture	3.28	8.86	7.14	1.72	1.0
Health	3.07	8.29	6.42	1.87	0.9
					0.0
<b>Infrastructure</b>	<b>145.03</b>	<b>391.59</b>	<b>210.88</b>	<b>180.71</b>	<b>43.1</b>
Road transport	44.81	120.98	74.96	46.02	13.3
Bridges	7.66	20.68	20.68	0	2.3
Water supply and water disposal	44.25	119.47	53.02	66.45	13.2
Water supply support works	1.85	5	5	0	0.6
River training	32.67	88.2	35	53.2	9.7
Electricity	3.09	8.34	3.5	4.84	0.9
Telecommunications	3.74	10.09	0.88	9.21	1.1
Forest roads	6.61	17.84	17.84	0	2.0
Airports and Seaports	0.37	0.99	0	0.99	0.1

Source: ECLAC estimates, based on country data and information

The main tourist hub in Soufriere and Vieux Fort were badly affected by the hurricane, suffering heavy flooding. Fortunately, however, only a few hotels suffered major structural damage. Meanwhile, in the north of the island structural and landscaping damage to hotels was contained, allowing for only temporary disruption of operations in the case of some properties. Losses in the tourism sector stemmed directly from damage to hotels that led to cancellation of some bookings and indirectly from the disruption of water supply that affected operations.

The agricultural sector, which remains an important generator of employment, although its contribution to GDP has waned over time, suffered damage to the tune of EC\$151.8 million. The banana crop was severely disrupted with whole fields being destroyed by the flooding and, to a lesser extent, wind damage. Moreover, the plants that have remained standing are expected to produce significantly reduced yields during the next crop. In addition, the fields would require major resuscitation investments in clearing, silt removal, fertilization and drainage to restore harvests to pre-Tomas levels.

Although less than the other key sectors; the social sectors suffered important damage and losses, amounting to EC\$209.2 million, 23% of the total impact. Housing bore the brunt of the fall-out in the social sector with estimated total effect of EC\$192 million, 92% of the impact in the sector. A large number of houses in Castries, Soufriere and Micoud, in particular, were badly damaged or destroyed. A number of these houses were owned by medium income earners and were, therefore, fairly more costly than those owned by low income households.

The impact on the education sector amounted to EC\$8.9 million. Some 63 schools suffered significant damage mainly from flooding, while some others had damage to their roofs and ceilings. However, the limited structural damage served to limit the total costs of the effects on the education sector. The health sector was impacted to the tune of EC\$8.3 million. A number of hospitals were damaged, particularly the Dennery Hospital, which accounted for half of the cost of the impact in the sector and had to be relocated.

## **B. MACROECONOMIC IMPACT OF HURRICANE TOMAS ON SAINT LUCIA**

### **1. MACROECONOMIC PERFORMANCE DURING THE FIRST HALF OF 2010**

Following the sharp downturn in 2009, when Saint Lucia felt the brunt of the fall-out from the global recession, the economy was posting a fledgling recovery in first three quarters of 2010, before the severe damage<sup>20</sup> suffered as a result of Hurricane Tomas. Mainstay tourism had recovered and was set to post good growth, especially the high-spending stay-over segment. Nevertheless, the return of growth was set against the backdrop of economic vulnerability underpinned by a deteriorating fiscal stance, marked by accelerated growth in fiscal deficit and public debt and the injection of an element of fragility into the banking system from rising non-performing loans consequent on weakened activity and employment and the fall-out from the CL Financial debacle.

In this environment, economic management needed to smooth the path for the return of private sector confidence and investment to drive growth, set in train a process of fiscal and debt consolidation that did not jeopardize growth and employment and facilitate improved competitiveness in agriculture, enclave manufacturing and tourism to position them for strengthened performance when the world economy rebounds fully.

#### **(a) Output and inflation**

The Saint Lucian economy recovered in the first half of 2010, following the downturn of 2009. Real output increased during the first half of 2010, compared with a contraction in the first half of 2009. The pick up in activity was driven by a rebound in tourism, linked to an 11.9% increase in high-spending stay-over visitors, which had declined by 9.7% in the first half of 2009. Recovery was fostered in part by a robust marketing initiative by the government, complemented by incentives to attract low cost carriers-

---

<sup>20</sup> Nevertheless, the impact of Hurricane Tomas was mainly damage (impact on the capital stock and other assets), with the losses being less. As such, the fall-out in GDP is expected to be less than might have been the case given the scale of the impact, had loss in value added been greater.

Jet Blue out of the United States and West Jet from Canada. In the case of the United State, this helped to lift arrivals by 31% to 68,776 visitors.

Cruise passenger arrivals posted a modest increase of 2.8% to 414,847 persons year on year to the first half of 2010, less than expected given the 9% increase in the number of cruise ship calls. Yachting arrivals expanded sharply (up 29.3%) in the first half of 2010, reversing an even larger decline in 2009 and bolstered by active promotion of Saint Lucia as a yachting destination complemented by the expansion and upgrading of the marina at Rodney Bay.

Reflecting the recovery in the numbers, visitor expenditure was estimated to have increased by 23% to EC\$305.8 million in the first half of 2010. Spending by visitors from major markets-the United State, Canada and United Kingdom was up, while spending by Caribbean visitors registered a sharp decline, probably reflecting the sharper contraction in the Caribbean as a result of the global recession. Importantly, the average daily spending by stay-over visitors recovered to grow by 1.7%, with the average for the three main markets increasing, which should have augured well for growth in 2010.

Agriculture, however, was buffeted by drought conditions, the high costs of inputs and disease infestations. Banana production fell by over 15% to 13,699 tonnes in the first half of 2010. Similarly, receipts from banana exports declined by 8.9% to EC\$25.7 million, but the fall in revenues was limited by increased exports of the higher valued special packs.

#### **(b) Government finances**

The continued need for the government to stimulate economic activity in an environment of weak private sector response has maintained the strain on the fiscal position. The stimulus programme in 2009 had resulted in a reversal of the small surplus of the previous year to a fiscal deficit to EC\$65.21 million (3.1% of GDP).

The deficit impulse was maintained in the first quarter of FY2010/11, when an overall deficit of EC\$7.4 million (1.4% of GDP) was recorded. The current account surplus narrowed to EC\$4.5 million, owing to increased spending and reduced revenue inflows and this was reinforced by a fall in capital grant receipts which led to a deficit on the capital account. Therefore, the primary surplus contracted sharply to EC\$13.7 million.

Incidentally, tax receipts increased, buttressed by higher returns from income and profit taxes, reflecting collection of arrears and from international trade and transactions on account of the higher value of imports. Meanwhile, current expenditure expanded by 21% to EC\$180.5 million with impetus coming from personal emoluments, goods and services and transfers. The spike in outlays on personal emoluments reflected the payment of retroactive salaries in April. Interest payments rose by 14.7% to EC\$21.1 million, in line with growth in the debt. Spending was also propelled by a hike in outlays on goods and services, including utilities and rental of offices.

Meanwhile, capital spending that contributes to productive capacity slipped by 5.7% to EC\$ 28.7 million, associated in part with the completion of important infrastructure projects such as the East Coast Road and Alan Bousquet Highway.

#### **(c) Monetary and exchange rate conditions**

Developments in the monetary sector were influenced by the below trend activity stemming from the global recession and the fledgling nature of the recovery in 2010. Broad money grew by a marginal 1.8% during the first half of 2010, relative to 5.3% for the previous year to date. What money supply growth



occurred was propelled by an increase in time and savings deposits. Similarly, credit growth was weak (up 1.5%), as banks became more discriminating in offering loans in light of high non-performance ratios and weak business sentiment in a continued climate of uncertainty limited the number of bankable projects that could be financed. The continued decline in credit to the productive sectors – down 9%, 6% and 1% for agriculture, manufacturing and tourism, nevertheless remains a cause for concern. However in a welcome development, credit to mining, fisheries and construction increased during the period. Consistent with the sluggish demand for credit, the weighted average lending rate fell by 19 basis points to 9.54%, while the weighted average deposit rate rose by 17 basis points to 3.31%, leading to a shrinking of the interest rate spread.

**(d) Balance of payments performance**

The current account of the balance of payments was expected to have improved during the first half of 2010. This was premised on an improvement in the merchandise balance and the recovery in tourism earnings. Domestic exports rebounded to grow by 38.9% to US\$40.8 million and re-exports doubled in value. Total exports were buoyed by higher exports of alcoholic and non-alcoholic beverages, as banana exports contracted by over 8%, reflecting the impact of earlier drought conditions and productivity problems. In addition, merchandise imports contracted by \$689.1 million due to lower imports of intermediate and capital goods.

Prior to Hurricane Tomas, economic activity was projected to remain firm during the second half of 2010, buoyed by dynamism in tourism and construction, although some dampening impulses were expected from weakness in agriculture and other sectors.

## 2. THE POST-DISASTER MACROECONOMIC PERFORMANCE

**(a) Overview**

The economic fall-out from Hurricane Tomas in 2010 was mitigated by the fact that relative to the total impact economic losses were contained<sup>21</sup> and the late arrival of the hurricane, with only two months left in the year, limited the duration of impact. The total money value of losses amounted to EC\$299.7 million, representing 14% of GDP. As a result, the loss of value added that would impact GDP would be less than it would have been the case, given the scale of damage and disruption from the hurricane. Although some of the dampening effects on agriculture are expected to carry over into 2011, this will be offset by rehabilitation and reconstruction work and, therefore, poses no downside risks to forecasted GDP growth in 2011.

**(b) Impact on GDP**

The fall-out in GDP, owing to the hurricane would depend on a number of factors, including the impact on and loss in value added in different sectors, the weight of the sectors in GDP, and the level of compensating spending, especially on rehabilitation and reconstruction to offset the impact of the hurricane.

Given, this fallout in value added, it is estimated that real GDP will decline by around 0.7% in 2010. In this event, the disaster is projected to lead to growth of about 1.0%, instead of the previous forecast of 1.7% in 2010. Nevertheless, this projection could be mitigated if the strength of post-disaster recovery in tourism prevails, especially as the dampening effects on agriculture will carry over into 2011.

---

<sup>21</sup> Nevertheless, the damage to the infrastructure and other capital assets has been severe, with the estimates of impact being conservative, and would entail significant costs in rehabilitation and reconstruction work.

With the major disruption in the water supply, owing mainly to the siltation of the main Roseau Dam and the impact on the electricity generation plant, growth in value added in electricity and water was projected to slow to 2.3% after Tomas down from 5.4% before the hurricane.

**Figure 14: The Impact of Hurricane Tomas on Real GDP Growth**

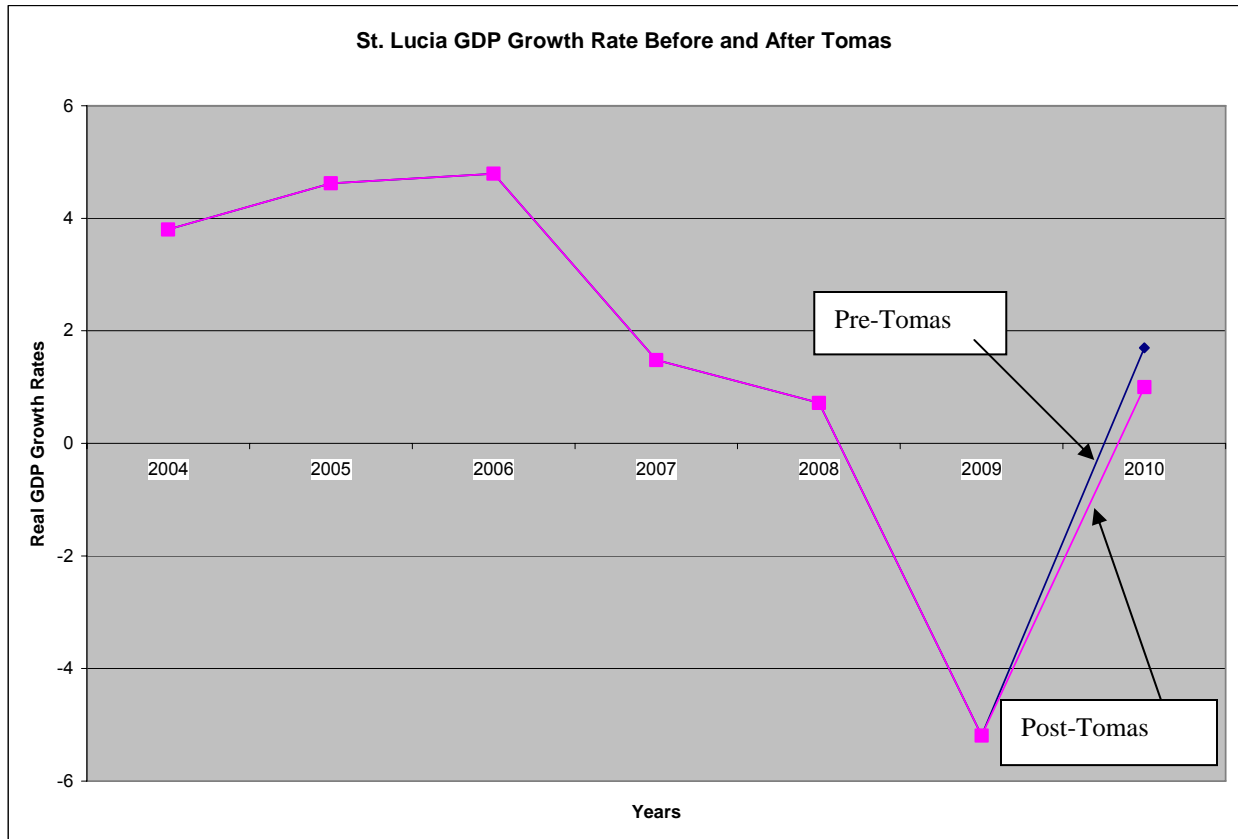

Source: ECLAC estimates based on impacts at the sector level

Hurricane Tomas led to significant loss in value added in the infrastructure sector, including water and electricity, roads and bridge transport, including agricultural roads. Furthermore, the productive sectors were disrupted, but the overall impact could have been worse if the wind intensity was greater. Nevertheless, banana and other crops were severely affected, leading to sharp falls in production that will carry over until August of 2011. A few upscale tourism properties suffered substantial damage, leading to important loss of business and necessitating significant outlays on reconstruction. However, most tourism properties suffered moderate flooding that did not lead to a major disruption of operations.

The contraction in agriculture will deepen after the hurricane (-9.6% before and -17.7% after Tomas). The banana crop was heavily impacted with an expected loss of EC\$17 million, due to flooding and wind damage. As a result, value added in the sector is now estimated to fall by 32.3%, compared with the earlier forecasted decline of 16.7%, prior to Tomas.

Meanwhile, growth in the mainstay tourism sector is projected to expand by 8.0%, down from 12.9% before Tomas, based on losses of EC\$46.1 million in the sector. The slackening of growth will result from loss of business and visitor expenditure in a number of tourist properties, due to flood damage and inadequate water supply in the aftermath of the hurricane. In addition, gross returns were squeezed by higher outlays on water due to damage to the main dam and disruption of transportation. Post-Tomas

The transport sector also suffered important fallout from flooding and landslides and is expected to contract by 0.4%, reversing the forecasted small growth of 0.8% prior to Tomas. A number of major roads and bridges were damaged or destroyed, including the Bois d'Orange Bridge and the Soufriere River Bridge. Nevertheless, the bulk of the impact is to the capital stock that would entail major spending for repairs and reconstruction next year and would not have a major impact on GDP in 2010.

The distribution sector (wholesale and retail trade) also suffered important damage and losses, although data on the full scale of the fallout has not been received. Based on monetary losses, loss in value added in the sector is estimated to lead to a contraction of about 2% in 2010. Meanwhile, the decline in the manufacturing sector is expected to increase marginally to 2.5%, related to damage to stocks, loss of production and increased transport and water procurement costs.

Growth in real estate and housing is estimated to be flat, reversing the 1% growth that was projected of 2010. Losses in the housing sector were contained, with damage accounting for the bulk of the impact. Many properties suffered flooding that led to the loss of contents, but were spared structural damage. Growth in government services were estimated to decline marginally, as the losses in education and health were relatively small.

Meanwhile, the decline in construction is projected to be substantially contained (-16% pre-Tomas and -1.1% post-Tomas) as the fall-out in activity is cushioned by post-hurricane public spending on rehabilitation works and private outlays on repairs by businesses and households. Public construction will focus on the restoration of key infrastructure, including major roads, bridges, river dredging, training and landslide mitigation. Private construction would centre on home repairs, repairs to the affected tourism plant and other businesses.

**(c) Prices, wages and employment**

The rate of inflation had increased year-on-year in the first half of 2010 by 1.1%, with impetus coming from food and beverages, education, clothing and footwear. The major output loss in the agricultural sector as a result of the hurricane will lead to domestic food shortages that will drive up prices in the short term. Impulses for higher inflation could also come from increased imports of more highly priced commodities, including fuel and building materials, in the wake of the hurricane. Indeed, the decline in the dollar and stronger demand, especially from China, has already led to an increase in commodity prices, which is expected to remain high into the early part of 2011.

**(d) Fiscal operations of central government and debt**

In the current environment, fiscal policy is the driving force in Saint Lucia. The need for fiscal stimulus to contain the fall-out in activity and employment in the wake of the global recession had put some strain on government finances. From FY2008/2009 to FY2009/2010, the primary balance was eroded (2.3% of GDP and -0.5% of GDP) and the overall deficit expanded from 1.0% of GDP and 4.0% of GDP).

The fall-out from Hurricane Tomas will complicate fiscal management for the authorities. The authorities had embarked on a programme of fiscal consolidation, which will have to be put on hold temporarily, as the government seeks to rebuild damaged and destroyed infrastructure that is necessary to productive activity, especially tourism and agriculture and also for social well-being. The authorities intend to make a strong case to the international community of the need to secure grant receipts to rebuild infrastructure and rehabilitate productive activity that is necessary for future economic growth. Nevertheless, even if a generous increase in grants materializes, it is still anticipated that significant debt will have to be contracted to rehabilitate the island's infrastructure, including water supply. It is strongly

urged that private and multilateral creditors provide these loan funds at the most favourable interest costs and maturity terms as possible. In addition, the rehabilitation of the agriculture and tourism sectors might require some government assistance, given that the sectors were already buffeted by weak global demand, owing to the recession in major markets.

**Table 71: The Fiscal Impact of Hurricane Tomas**

<b>Central Government Fiscal Operations (\$M)</b>				<b>Projections</b>
	<b>2007/08</b>	<b>2008/09</b>	<b>2009/10</b>	<b>2010/11</b>
<b>Total Revenues and Grants</b>	<b>742.78</b>	<b>816.46</b>	<b>809.13</b>	<b>854.00</b>
Capital Grants	4.14	20.47	52.75	69.01
Capital Revenue	0.00	6.72	0.04	8.82
<b>CURRENT REVENUE</b>	<b>738.64</b>	<b>789.27</b>	<b>756.34</b>	<b>776.17</b>
<b>Tax Revenue</b>	<b>684.57</b>	<b>736.21</b>	<b>702.79</b>	<b>737.79</b>
<b>Taxes on Income</b>	<b>195.78</b>	<b>230.91</b>	<b>219.11</b>	<b>221.94</b>
Individuals	71.33	75.97	77.43	81.16
Withholdings	5.22	12.26	11.58	14.56
Corporations	91.95	113.70	94.18	90.30
Arrears	34.91	37.52	42.22	43.41
Tax Refunds	-7.63	-8.55	-6.30	-7.50
<b>Tax on Property</b>	<b>5.16</b>	<b>2.73</b>	<b>3.92</b>	<b>3.24</b>
Property Tax	5.16	2.73	3.92	3.24
<b>Tax On Goods And Services</b>	<b>125.41</b>	<b>122.84</b>	<b>108.32</b>	<b>129.26</b>
<b>VAT</b>				
Consumption tax (domestic)	9.85	6.38	6.35	5.17
Excise tax (Domestic)	2.59	6.61	9.73	13.05
Hotel Occupancy tax	33.45	35.02	24.50	35.88
Insurance Premium Tax	7.17	7.41	6.83	6.95
Licences	22.20	19.39	20.56	26.00
Fuel Surcharge	3.57	3.63	4.06	3.87
Stamp Duties (inland revenue)	31.49	25.70	20.12	16.63
Cellular Tax	11.95	12.81	12.56	16.85
Passenger Facility Fee	3.14	5.89	3.61	4.85

Table 71: continued

<b>Taxes on International Trade and Transactions</b>	<b>358.22</b>	<b>379.74</b>	<b>371.45</b>	<b>383.36</b>
Import Duty	107.01	103.65	93.25	100.92
Consumption tax (imports)	112.24	136.28	140.17	117.69
<i>Ctax on other imports</i>	<i>112.24</i>	<i>112.47</i>	<i>102.57</i>	<i>117.69</i>
<i>Ctax on petroleum products</i>	<i>0.00</i>	<i>23.81</i>	<i>37.60</i>	<i>0.00</i>
Thruput Charges	3.11	6.52	7.88	5.60
Travel Tax	3.30	4.41	3.60	3.57
Service Charge (imports)	64.77	67.93	58.99	63.04
Environmental Levy	18.03	15.97	14.35	16.66
Surcharge on Int'l Calls				
Airport Tax	5.90	11.81	10.05	10.78
Excise tax (Imports)	42.98	32.23	41.65	64.58
<i>petroleum</i>	<i>0.00</i>	<i>0.00</i>	<i>20.91</i>	<i>44.16</i>
<i>excise tax other imports</i>	<i>42.98</i>	<i>32.23</i>	<i>20.74</i>	<i>20.42</i>
Security Charge (SLASPA)	0.88	0.93	1.51	0.52
<b>Non-Tax Revenue</b>	<b>54.08</b>	<b>53.06</b>	<b>53.55</b>	<b>38.38</b>
Earnings From Govt. Depts.	1.48	-13.22	-4.79	-7.77
E.C.C.B. Profits	3.32	6.96	4.53	5.29
Interest and rents	13.14	15.63	13.06	8.81
Fees, Fines and Sales	27.32	33.23	30.82	18.35
Other Non Tax Revenues	8.83	10.45	9.93	13.70
<b>Wages and Salaries</b>	<b>265.22</b>	<b>298.91</b>	<b>316.52</b>	<b>341.55</b>
Wages	35.49	38.24	39.52	40.50
Salaries	229.73	246.04	276.50	293.11
Retro-active	0.00	14.64	0.50	7.94
<b>NIS</b>	<b>5.60</b>	<b>5.79</b>	<b>7.25</b>	<b>8.79</b>
<b>Retiring Benefits</b>	<b>43.62</b>	<b>45.61</b>	<b>50.15</b>	<b>56.12</b>
<b>Interest Payments</b>	<b>84.12</b>	<b>87.74</b>	<b>89.71</b>	<b>94.49</b>
Domestic	30.66	44.06	46.24	53.80
Foreign	62.25	46.78	43.47	40.69
<b>Goods and Services</b>	<b>114.11</b>	<b>131.69</b>	<b>130.47</b>	<b>138.25</b>
Travel & Subsistence	9.52	10.75	10.36	10.38
Utilities	20.07	23.78	19.90	21.90
Supplies & Materials	16.03	20.17	21.08	21.83
Operating & Maintenance	15.83	18.32	18.52	19.32
Rental	23.36	27.32	28.17	31.80
Communications	8.14	9.51	9.74	9.42
Other	21.15	21.85	22.70	23.61
<b>Current Transfers</b>	<b>65.08</b>	<b>74.16</b>	<b>77.06</b>	<b>83.37</b>
Public sector	58.59	61.58	58.51	63.39
Private Sector	6.50	12.58	18.54	19.98
Subsidies	2.53	6.97	13.66	12.20
Other	3.96	5.62	4.88	7.78

Table 71: continued

<b>TOTAL CURRENT EXPEND. (exc principal &amp; SKF)</b>	<b>577.74</b>	<b>643.91</b>	<b>671.14</b>	<b>722.56</b>
	<b>32.9%</b>			
<b>CAPITAL EXPENDITURE</b>	<b>181.93</b>	<b>198.91</b>	<b>241.60</b>	<b>256.20</b>
Local Revenue				
Grants				
Loans				
Bonds				
<b>Cap Ex/GDP</b>	<b>7.0%</b>	<b>7.5%</b>	<b>9.4%</b>	<b>9.5%</b>
<b>TOTAL EXPENDITURE</b>	<b>759.67</b>	<b>842.81</b>	<b>912.74</b>	<b>978.76</b>
Principal Repayments	66.15	72.90	76.93	82.84
Sinking Fund Contributions	16.27	12.99	10.68	7.74
<b>Total principal Debt payments</b>	<b>82.42</b>	<b>85.89</b>	<b>87.60</b>	<b>90.58</b>
<b>Budget recurrent expenditure</b>	<b>667.40</b>	<b>753.40</b>	<b>788.20</b>	
<b>R&amp;P Conversion to Recurrent Expenditure</b>			<b>765.04</b>	<b>823.44</b>
<b>GRAND TOTAL EXPENDITURE</b>	<b>842.09</b>	<b>928.70</b>	<b>1,000.35</b>	<b>1,064.37</b>
<b>Current Balance MOE (excluding principal &amp; SKF)</b>	<b>160.90</b>	<b>145.36</b>	<b>85.20</b>	<b>53.61</b>
<b>(% GDP) (4%)</b>	<b>6.1%</b>	<b>5.5%</b>	<b>3.3%</b>	<b>2.0%</b>
<b>Recurrent Balance</b>	<b>78.48</b>	<b>59.47</b>	<b>-2.40</b>	<b>-36.97</b>
<b>(% GDP)</b>	<b>3.0%</b>	<b>2.2%</b>	<b>-0.1%</b>	<b>-1.4%</b>
<b>Primary Balance</b>	<b>67.23</b>	<b>61.39</b>	<b>-13.90</b>	<b>-30.27</b>
<b>(% GDP)</b>	<b>2.6%</b>	<b>2.3%</b>	<b>-0.5%</b>	<b>-1.1%</b>
<b>Overall Balance (before grants)</b>				
<b>Overall Balance (after grants)</b>	<b>-16.89</b>	<b>-26.35</b>	<b>-103.61</b>	<b>-124.76</b>
<b>(% GDP)</b>	<b>-0.6%</b>	<b>-1.0%</b>	<b>-4.0%</b>	<b>-4.6%</b>

Source: Government of Saint Lucia data and ECLAC estimate

The impact of the hurricane on government finances is expected to fall primarily on the expenditure side. The overall fiscal deficit is expected to increase from EC\$103.6 million (4.0% of GDP) in FY2009/10 to EC\$124.8 million (4.6% of GDP) in FY2010/11 based on indications of government spending for relief, rehabilitation and reconstruction work. At the same time, government dis-saving will increase as the primary deficit rises from EC\$13.9 million (0.5% of GDP) in FY2009/10 to EC\$30.3 million in FY2010/11. Total revenue and grants is actually expected to increase by over 5%, related to higher tax revenues, owing mainly to the increase in revenues prior to the hurricane with the pickup in activity after the downturn in 2009. Grant receipts rose sharply (30.8%), largely reflecting post-hurricane assistance. Although revenues would have been dampened after the hurricane, the short duration of the fall-out would have mitigated the overall fall-out for the fiscal year. However, the growth in revenue was offset by a larger 7.2% increase in expenditure<sup>22</sup>, related partly to both current outlays and capital spending on infrastructure rehabilitation in the aftermath of hurricane Tomas.

Current revenue was projected to increase by 2.6% to EC\$854 million, as the late arrival of the hurricane has limited the fall-out on revenue collections. Tax receipts were projected to rise by 5.0%, owing to the improved performance in the period prior to the hurricane when economic activity strengthened on the backs of improved performance of the tourism sector, which offset the dampening

<sup>22</sup> The demand to rehabilitate and rebuild damage infrastructure, particularly the water supply, roads and bridges and also to dredge and train rivers is quite high, given their importance to the day to day functioning of the economy and society.

effects of the hurricane. Taxes on income were projected to increase by 1.3%, while taxes on goods and services were projected to grow strongly by over 19%, stemming mainly from dynamic growth in hotel occupancy tax and excise tax. In spite of anticipated government concessions to importers for the purchase of building materials and equipment for rehabilitation work, taxes on international trade and transactions were expected to rise by over 3%, as the increase in receipts stemming from higher imports for reconstruction, negate any loss of revenues from concessions.

Total expenditure is expected to increase by around 7%, propelled by higher current and capital outlays. Capital expenditure is expected to increase by around 6% (EC\$14.6 million) in 2010/11. Growth in spending reflected both outlays on roads and other public infrastructure prior to the hurricane and the rehabilitation and reconstruction of damaged roads and bridges and the dredging of rivers after the hurricane.

Current spending is projected to increase by 7.7% associated with higher outlays on wages and salaries, goods and services and current transfers, including assistance and relief to affected citizens. It is anticipated that significant rehabilitation and reconstruction work will continue into 2011, especially to incorporate mitigation measures in the reconstruction of roads, bridges and geotechnical engineering to reduce the risk of landslide in prone areas.

Hurricane Tomas is expected to lead to higher public sector indebtedness in the short term. Fortunately, given its prudent debt management strategy in the past, the government should be able to raise some resources through a bond issue on the ECCB Regional Government Securities market. However, this probably would not obviate the need for external borrowing. Preliminary indications are that total public debt is expected to increase by some EC\$116 million in 2010, lifting its total debt to \$2,010.6 million to 75% of GDP at the end of 2010.

**(e) Monetary and exchange rate conditions**

Monetary conditions are expected to tighten in the wake of Hurricane Tomas. The slowdown in activity, especially in the high-spending Christmas season will lead to slower growth in deposit liabilities and credit growth. Growth in credit is projected to decelerate in line with the fall-out in activity and rise in uncertainty. Moreover, credit quality is expected to worsen with the non-performing loans ratio of some banks increasing with dampened activity and employment. Some businesses, including hotels, are also expected to draw down foreign assets to facilitate repairs and rehabilitation to affected properties.

**(f) Impact on the balance of payments**

The evolution of the balance of payments in the aftermath of Tomas will be influenced by the fallout in export receipts from tourism and agriculture, growth in imports for reconstruction and rehabilitation and the extent of increased grant receipts from donors. Overall, these developments are expected to lead to widening of the current account deficit in 2010 from 18.3% of GDP before Tomas to 25.9% of GDP after Tomas (see table 72).

Table 72: The Impact of Hurricane Tomas on the Balance of Payments

					Pre-	Post-
					Hurricane	Hurricane
					Tomas	Tomas
	2006	2007	2008	2009r/	2010p/	2010
<b>Balance of Payments</b>						
<b>I. CURRENT ACCOUNT</b>	<b>-87.4</b>	<b>-150.1</b>	<b>-302.7</b>	<b>-138.3</b>	<b>-140.2</b>	<b>-198.5</b>
<b>Percentage of GDP</b>	<b>-11.4</b>	<b>-19.6</b>	<b>-39.6</b>	<b>-18.1</b>	<b>-18.3</b>	<b>-25.9</b>
Goods: exports f.o.b.	96.3	88.8	96.7	191.3	174.7	152.5
Goods: imports f.o.b.	-348.0	-418.1	-520.9	-451.5	-467.8	-482.8
<b>Balance on Goods</b>	<b>-251.7</b>	<b>-329.3</b>	<b>-424.3</b>	<b>-260.2</b>	<b>-293.1</b>	<b>-330.3</b>
Services (Credit)	367.1	410.5	334.2	352.6	379.5	357.2
Transportation	15.3	21.6	21.7	18.7	19.1	16.9
Travel	325.7	356.0	284.6	296.2	325.7	308.6
Other services	26.2	32.9	27.9	37.7	34.7	31.7
Services (Debit)	-147.7	-171.7	-168.9	-190.0	-180.2	-186.7
Transportation	-64.1	-73.5	-80.6	-74.9	-74.7	-79.2
Travel	-36.8	-38.9	-39.3	-46.7	-42.7	-37.7
Other services	-46.8	-59.3	-49.0	-68.4	-62.9	-69.9
<b>Balance on Services</b>	<b>219.4</b>	<b>238.8</b>	<b>165.3</b>	<b>162.6</b>	<b>199.3</b>	<b>170.5</b>
Balance on Goods and Services	-32.3	-90.6	-259.0	-97.6	-93.8	-159.8
Income (Credit)	6.2	8.1	10.4	11.5	7.1	5.8
Compensation of employees	6.2	6.6	7.2	0.2	0.2	0.2
Investment income	0.0	1.5	3.2	11.3	6.9	5.6
Direct investment	0.0	0.0	0.0	11.3	0.1	0.1
Portfolio investment	0.1	0.1	1.5	0.0	2.0	1.9
Other investment	0.0	1.5	1.7	6.0	4.8	3.6
Income (Debit)	-75.2	-80.6	-66.1	-64.6	-68.4	-65.4
Compensation of employees	0.0	0.0	0.0	0.0	0.0	0.0
Investment income	-75.2	-80.6	-66.1	-64.6	-68.4	-65.4
Direct investment	-24.7	-30.7	-41.6	-35.3	-32.4	-31.4
Portfolio investment	0.0	0.0	-2.6	-4.0	-4.0	-4.0
Other investment	-50.5	-49.9	-21.9	-25.4	-32.0	-30.0
<b>Balance on income</b>	<b>-69.0</b>	<b>-72.5</b>	<b>-55.7</b>	<b>-53.1</b>	<b>-61.3</b>	<b>-59.6</b>
Current transfers (Credit)	29.9	29.7	31.4	32.1	32.8	38.8
Current transfers (Debit)	-16.0	-16.7	-19.4	-19.6	-17.9	-17.9
<b>Balance of transfers</b>	<b>13.9</b>	<b>13.0</b>	<b>12.0</b>	<b>12.4</b>	<b>14.9</b>	<b>20.9</b>
<b>II. BALANCE ON CAPITAL ACCOUNT a)</b>	<b>3.5</b>	<b>5.3</b>	<b>11.4</b>	<b>25.8</b>	<b>18.5</b>	



Table 72: continued

<b>III. BALANCE ON FINANCIAL ACCOUNT</b>						
<b>a)</b>	<b>106.3</b>	<b>122.7</b>	<b>309.5</b>	<b>158.7</b>	<b>129.0</b>	
Direct investment abroad	0.0	0.0	0.0	0.0	0.0	
Direct investment in the country	76.5	78.2	233.9	146.4	99.1	
Portfolio investment assets	0.9	0.2	-7.8	-0.2	0.0	
Equity securities	0.0	0.0	0.0	0.0	0.0	
Debt securities	0.0	0.0	0.0	0.0	0.0	
Portfolio investment liabilities	15.4	23.9	4.8	-8.6	-8.3	
Equity securities	0.0	0.0	0.0	0.0	0.0	
Debt securities	0.0	0.0	0.0	5.2	0.0	
Other investment assets	56.1	81.8	116.4	4.7	12.4	
Monetary authorities	0.0	0.0	0.0	0.0	0.0	
General government	0.0	0.0	0.0	0.0	0.0	
Banks	0.0	0.0	0.0	0.0	4.1	
Other sectors	56.1	81.8	116.4	9.1	8.3	
Other investment liabilities	-42.6	-61.5	-37.9	16.3	25.8	
Monetary authorities	0.0	0.0	0.0	0.0	0.0	
General government	0.0	0.0	0.0	7.5	9.7	
Banks	0.0	0.0	0.0	80.2	0.0	
Other sectors	-42.6	-61.5	-37.9	8.8	16.1	
<b>IV. NET ERRORS AND OMISSIONS</b>	<b>4.5</b>	<b>6.9</b>	<b>-4.3</b>	<b>-13.2</b>	<b>11.0</b>	
<b>V. GLOBAL BALANCE</b>	<b>26.8</b>	<b>-15.2</b>	<b>13.9</b>	<b>33.2</b>	<b>18.3</b>	

Source: The Government of Saint Lucia, ECCB and ECLAC estimates.

However, the larger current account deficit will be covered by capital inflows, which would respond for reconstruction and recovery. The merchandise deficit is projected to expand by over 12%, owing to a more than 12% contraction in export receipts and a 3% growth in imports. Banana exports receipts are projected to decline by some US\$3.4 million due to severe damage to the crop, with a large percentage of plants damaged or destroyed. Indeed, the bulk of production and export losses are expected in 2011, when the full harvest cycle is expected to be severely impacted, export losses of US\$5.7 million are projected for 2011. Exports of manufactured goods are expected to decline marginally due to lower exports of food and beverages.

Growth in imports are projected to increase by 3.2% (US\$15 million) in 2010, as the bulk of the significant infrastructure works will take place in 2011. Higher imports will reflect mainly the procurement of equipment, machinery and building materials for rehabilitation and reconstruction works.

The services account surplus is projected to contract by some 14%, dampened by a 5.3% (US\$17.1 million) decline in tourism receipts. The fallout in tourism stemmed mainly from damage to a few luxury properties and minor flooding in other properties that led to disruption of business. The disruption of the water supply and visitor perception of the scale of the impact led to the cancellation of some bookings. Nevertheless, for the overall scale of damage, the fallout was contained. Some impact is expected to carry over to 2011, but an aggressive marketing campaign by the authorities to inform visitors that the country is will soon be fully open for business is expected to limit the fallout next year.

The balance on the income account is expected to contract marginally, owing to reduced investment income paid abroad due to the fallout in activity and as firms limit profit repatriation to fund reconstruction activities.

The balance on current transfers has been modest in the last few years, averaging US\$12.5 million in the last three years. In the aftermath of the hurricane, current transfers are projected to increase by about US\$6 million, responding to higher remittance inflows, as families abroad provide assistance to relatives and friends. Transfers will also be buoyed by official receipts for relief and recovery in the aftermath of the hurricane. The larger current account deficit is expected to be covered by capital inflows, partly for repairs and reconstruction in tourism.

## V. PLANNING AND MITIGATION

### A. SETTLEMENTS

#### 1. BACKGROUND

The combined effect of damages, reported and observed, to some productive sectors, social sectors, infrastructure and the environment is quite obvious from the impact on settlements located in flood plains and within the shadows or hydrological influence of steep slopes vulnerable to mass soil movement. Impacts are associated not only with the location of settlements, but with inadequacies in how they are designed, particularly with respect to layout and storm water drainage infrastructure.

Runoff increases with higher densities, so effective storm water management strategies are required to reduce the risk to flooding. Such strategies must also be applied to areas that have been reclaimed from the sea (example, sections of Castries) or sites that have been land filled to elevate building sites (examples are rapidly developing areas within the Castries – Gros Islet/Rodney Bay corridor).

Many of the older coastal settlements of Saint Lucia emerged from villages and evolved firstly as compact communities characterized by small plot sizes, high plot cover (ratio of building cover to plot size), site cover (ratio of coverage by buildings and impervious surfaces to plot area), and building height of one and two storeys generally. Although several of these settlements are considered rural, many are distinctly urban in character, in density, building and site coverage, layout, and mix of residential, commercial, and civic uses.



**Left Photo: Coastal Section of Dennery; Right Photo: Poorly laid out in-land Settlement at Higher Elevations**

Older communities (and their more recent additions) and newer settlements exist in different types of terrain and are subjected to various kinds and levels of risks, the effects of which were obvious from damages suffered during Tomas. Settlements in the low lying areas at the mouths of rivers and those in river plains of inland areas are at greater risk to flooding and large deposits of sediment and debris, than those in mountainous steep areas of watersheds or drainage basins, where the major threat is from landslips and other forms of soil movement.

Settlements with illegal development activity, such as squatting and/or building without development permission, are known to be generally most prone to hazards. Where such activities occur,

the retrofitting required to improve roadways, drainage infrastructure and public amenities is quite costly and rarely achieves desired standards for risk reduction.

## **2. DAMAGE AND LOSSES**

Parts of several settlements were inundated with flood waters, examples being, Bexon, Dennery, Canaries, Soufriere, Anse La Raye, and Castries. Numerous landslips on slopes above and within settlements resulted in large quantities of sediment being washed down-slope, blocking rivers, ravines and other waterways and disrupting life in affected settlements.

Cost of damages and loss for houses, schools, hospitals and clinics are presented for the social sectors (housing, health and education), and for commercial and tourism facilities located in settlements in other sections of this report. Similarly, damages to the access and internal roads of settlements, water, electricity, telephones, communications and other utilities are provided under infrastructure, while damages and loss suffered by natural areas are counted in the environmental sector.

More general disruption to life within settlements includes losses not fully covered in sector reporting due to lack of sufficient data. A significant part of the costs listed in the infrastructure sector for the removal of flood related sediment, muck and debris is linked to settlements such as Bexon, Soufriere and Fond St. Jacques.

Also, loss associated with the use of public amenities, (parks, gathering places, aesthetic or historic value of streetscapes) and recreational facilities is difficult to measure but can adversely affect the welfare of a community, in the short or medium term. Nevertheless, impacts are noted to help inform strategies for reducing the vulnerability of settlements to future events:

- (a) Restricted vehicle and pedestrian circulation due to standing flood waters, sediment and/or debris on roads and driveways and washed out roadways
- (b) Temporary (days/weeks) loss of on-street parking and off-street parking for the same reasons
- (c) Damage and loss to parked and stored vehicles during the event: Thirty-two vehicles stored by an automotive repair shop for insurance companies and other clients were reported to be washed away by flood waters and buried in sediment in Bexon
- (d) Damage to recreational facilities and loss of use. Open fields used by schools and communities for cricket, football and activities for recreation, fitness and social events were flooded for an extended period. In some cases they were covered by sediment, gravel and debris deposited by flood waters (Fond St. Jacques, Soufriere). In other instances, they were used temporarily to stockpile sediment from public and private property (Soufriere and Fond St. Jacques).
- (e) Businesses, livelihoods and community events. The overall effect on businesses and livelihoods in communities is the combined effects of damage to roads, utilities, and other services. Loss of electricity, telephone, water and internet services affected not only commerce but small home-based businesses which depend on essential services in the use of computers for data transfers and banking, communications with clients, and internet searches. The damages also disrupted the rhythms of community life by adverse effects on social, religious and civic functions.

(f) Environment. The environment of urban and rural settlements combines natural and built features. Rivers (Soufriere, Cul de Sac) are major features of the natural environment for Soufriere and Bexon/Marc, while remaining un-built un-surfaced areas of their flood plains function to grow vegetative cover, provide for the infiltration of flood waters into soil, store and slowly release flood waters in depressions and help to regulate sub-surface drainage, all of which help to reduce flood impacts under normal rainfall conditions. Flood waters and vast quantities of sediment and debris compromised the functions of natural areas of the Bexon /Marc flood plain (at least temporarily) and impaired aesthetic and visual values of affected settlements. In Bexon, visual issues were also associated with damaged cars, old tyres, and various stored items dislocated from businesses and homes by flood waters.

## **B. LAND USE AND PLANNING**

### **1. BACKGROUND**

Mountainous terrain, steep slopes and narrow valleys of the country are conditions favoring rapid water runoff during periods of significant rainfall even for drainage basins with adequate vegetation cover. Such conditions also present severe challenges in finding sufficient land to accommodate the growth in settlements and new residential subdivisions resulting from increases in population, affluence and aspirations of the middle class, changing lifestyles and reduced size of the average household.

As natural vegetation cover gives way to houses, roads, businesses, and, to a lesser extent, farms, the ratio of runoff to precipitation increases and flooding becomes more frequent. Trends indicate that the country's tradition of building on slopes and close to rivers continues. The only statistics obtained on development applications were for the Gros Islet/Babonneau area of the country. The data presented in table 73 revealed that 72% of applications submitted were for residences and subdivisions. There is a relatively high approval rate of 80% for all applications. If this reflects what is happening in most of the country, impacts from building in areas prone to hazards could increase in the absence of more effective planning and development control of residential subdivision and construction.

Land ownership parcel maps overlaid on aerial images for Bexon and Fond St. Jacques/Migny revealed a mixture of small and large plots, many of which can accommodate significant development of residences and farms in moderate to fairly steep areas, should owners decide to use their lands for such purposes. Uncontrolled development in these sites would increase risks to residents and add to the general vulnerability of the country.

**Table 73: Gros Islet/Babonneau Development Applications, January – October 2010**

Type of Development	Applications submitted		Applications approved	
	#	%	#	%
Residential	206	43.2	182	88.4
Small Subdivisions (< 5 lots)	152	31.9	117	76.9
Large Subdivisions	10	2.1	6	60.0
Other	109	22.8	80	73.4
Total	477	100%	385	80.7

Source: Physical Planning Section

### **2. ENABLING LEGISLATION FOR PHYSICAL PLANNING**

Part 2, Section 10 of the Physical Planning and Development Act, (Revised Edition), 2005 provides for the preparation of physical plans “for Saint Lucia as a whole or for any specified part” of the country and

for their approval by the House of Assembly following a process of public review and approval by the responsible government minister.

Responsibility for preparing physical plans rests with the Physical Planning Section of the Ministry of Physical Planning, Development and the Environment, which provides technical and administrative support to the Development Control Authority (DCA). Physical plans are intended to organize social and economic development, while sustaining the environment and the services it offers. Such plans are expected to provide the framework and critical guidance for decision-making on development applications. A challenge for planning authorities in Saint Lucia, like other countries in the OECS, is to gain public support for the application of national land use plans as statutory instruments for land zoning. Hurdles have been less, but marginally so, to gain both public and political support for the approval of sub-national plans for regions, settlements or parts thereof.

In the absence of approved plans with effective legal authority, the DCA regulates development using planning approval procedures which, in the absence of zoning, are applied with discretion and a certain degree of flexibility. Planning approval decisions are informed by land capability designations (prescribed mainly for agriculture), existing hazard maps with deficiencies with respect to accuracy and scale, limited Government Information System (GIS) analysis of land use issues and potentials, rapid site observations and appraisals, and local knowledge.

### **3. DATA MANAGEMENT AND MAPPING TOOLS**

Consultations with stakeholder agencies and professionals reveal a number of critical issues that must be resolved in relation to data management, planning and development control:

- (a) Updating of existing hazard maps, which are not adequate for site specific analysis of hazard risk for planning and development control
- (b) Development of a National GIS, for management of spatial data in support of planning, risk and hazard analysis, and development control
- (c) Additional Resources to build capacity at the Physical Planning Office for the preparation of National Plans and for Monitoring and enforcement of land development and building to ensure compliance with land development and building approval
- (d) Training of staff to meet the administrative and technical requirements of the Physical Planning Section

### **4. PLANNING AND ENFORCEMENT CAPACITY**

Perhaps the single most critical issue facing the Physical Planning Section and the DCA is limited technical and administrative capacity for plan preparation and enforcement of building codes and standards. This severely affects their performance in mitigating environmental damage from development and the socio-economic impacts from natural disasters. The Physical Planning Section has indicated a need to increase its staff to (a) build capacity for effective research, analysis and plan preparation, (b) provide adequate cover for regular appraisals of development, monitoring and enforcement of land development and building activity in its eight administrative zones used by Building Inspection Officers, (c) allow development of a specialized unit for monitoring and enforcement, and (d) create an effective communications unit to promote public awareness, education and effect public support.

The Physical Planning Section also endeavors to upgrade its operating systems for filing of development applications, management of data, quick access and retrieval of information for decision-making, among other needs. It recognizes existing weaknesses or gaps in a number of areas: (a) enabling laws for planning and development control, (b) the draft building code, which is yet to be approved for the country, (c) regulations that have been drafted but not passed into law, and hence lack the legal authority to enforce standards for land development and building construction critical to hazard mitigation, and (d) application of development project assessment procedures, such as Environmental Impact Assessments (EIAS). It is currently working with a committee of stakeholder agencies and persons to address these issues but requires additional technical assistance for a comprehensive gap analysis of its administrative, technical and other operational needs.

## **5. BUILDING AND LAND DEVELOPMENT PRACTICES AND STANDARDS**

### **(a) Practices**

The Team observed and various stakeholders articulated the need to change building practices to gradually improve the readiness of the country to cope with hazards such as Tomas. Issues are not only inherent to the design and erection of structures but critically to site preparation, including vegetation clearance, excavation and soil management at construction sites, particularly on slopes.

Clearing of lands on slopes for agriculture constitute a form of development with similar consequences to building activity. Building and agricultural practices, separately or in combination, are partly responsible for land slips, soil erosion and other forms of soil movement, failed storm water drainage systems, bridges, and culverts, and flooding of properties among other damages suffered during Hurricane Tomas.

### **(b) Existing standards**

The OECS Building Code for Saint Lucia (Draft), like the codes for all other States in the grouping, is based on the Caribbean Uniform Building Code (CUBiC) and informed by codes from Jamaica, the Bahamas and Turks and Caicos Islands. OECS Governments recognized the importance of the Code as a response to damages and losses experienced by Members of the Grouping from frequent hurricanes and, less frequently, from earthquakes.

Saint Lucia's Draft Building Code is used by the DCA to enforce building standards but the document is under review for upgrading with the aim to have it approved. However, because of illegal development and lack of resources to enforce the code, building practices continue to be a major factor in the vulnerability of settlements. There are deficiencies in the scope and stringency of the building standards, particularly with respect to specific minimum requirements for building in hazardous areas. In addition, comparable and effective land development or land use standards are required along with the improved Building Code to address adverse impacts from land development practices. Relevant land use standards to be prepared or revised in this respect are:

- (a) Planning and infrastructure design for residential subdivisions
- (b) Vegetation clearance for building and farming in selected areas, for example, steep slopes, river banks
- (b) Erosion control measures for excavation, other site works and soil storage
- (c) Erosion control measures for farming on steep slopes, example, contouring, terracing

- (d) Setback limits for developments next to rivers, inclusive of farming activities
- (e) Storage of toxic or hazardous substances in hazard prone areas
- (f) Installation of poles, transmission lines and conduits used for water, electricity, audio and data communications

## 6. PROJECT CONCEPTS

Concepts for projects to address needs identified for Physical Planning and Development Control have been prepared and appended. These are: (a) Updating and improving hazard maps for Saint Lucia, (b) Development of a national GIS system and data management network for Saint Lucia, and (c) Building the capacity for physical planning and enforcement of codes and standards in the Physical Planning Office of Saint Lucia.

### C. MITIGATION FOR VULNERABILITY REDUCTION STRATEGIES

#### 1. INITIAL RESPONSES: SELECTED SETTLEMENTS AND HOSPITALS

##### (a) Fond St. Jacques

Extensive and traumatic damages to Fond St. Jacques, resulted in evacuation of residents and will require rebuilding of what can be considered a mountain based settlement. Major consideration must be given to enforcement of land development and building standards for Fond St. Jacques to reduce risk and vulnerability to future hazards.



**Photographs:** Clockwise from the Top: (1) Damaged homes & sediment deposits, Fond St. Jacques, (2) Damages to Dennerly Hospital (3) Building for temporary accommodation of health services in Dennerly (4) School in Bexon in flood waters inundated area (5) Sediment deposited in open play area at complex of educational facilities in Soufriere



Fond St. Jacques requires immediate attention, using a three-phased strategy, including: (a) Phase 1: a rapid technical analysis of existing and future conditions and presentation of required design and other parameters to inform reconstruction activities, (b) Phase 2: planning and engineering design for a reconstructed settlement broadly zoned into two categories, namely a build zone and a natural zone, and (iii) Phase 3: Construction or installment of roads, homes, infrastructure and public amenities to strict hazard mitigation standards.

**(b) Mitigation for essential services: Hospitals and schools**

Issues of design deficiencies with respect to wind damage, age and inadequate maintenance needs to be addressed for buildings housing essential services, such as hospitals and schools. Combinations of these factors contributed to the wind damage suffered by Soufriere and Dennery hospitals from a Category 1 event which, ideally, they should have been designed and maintained to withstand. In the case of Soufriere the hospital was decommissioned and the complex of schools and educational facilities within the same section of the Town was made unusable up to three weeks after the disaster.

The Dennery Hospital is to be demolished and a temporary building has been identified to accommodate reduced health services. This building requires extensive repairs, remodeling and retrofitting to increase resistance to hurricane damage. Its location next to the busy highway that passes through the settlement is not ideal for patient care and also presents issues for vehicles entering and leaving the facility.

In addition to the rebuilding already identified for key social infrastructure, immediate action is needed to assess the vulnerability of selected hospitals, schools, clinics and other structures to the future hazards. A project is proposed to undertake a number of vulnerability audits, the results of which would guide retrofitting of structures, where possible, for wind and flood resistance.

**(c) Longer-term actions: Soufriere and Cul De Sac watersheds**

Long-term initiatives are proposed in the form of multi-stakeholder collaboration projects for the Cul de Sac and Soufriere watersheds, both of which have a history of hazard-related disasters. Reminders of the severity of the vulnerabilities of sections of these watersheds are fatalities associated with landslides in the Ravine Possion incident of the 1930s and, more recently, deaths from hurricanes, including Tomas, in Fond St. Jacques. The projects are designed to lessen the socio-economic impacts on settlements and productive activities in these watersheds.

Figure 15: Selected Mitigation Measures against Hazard Damage

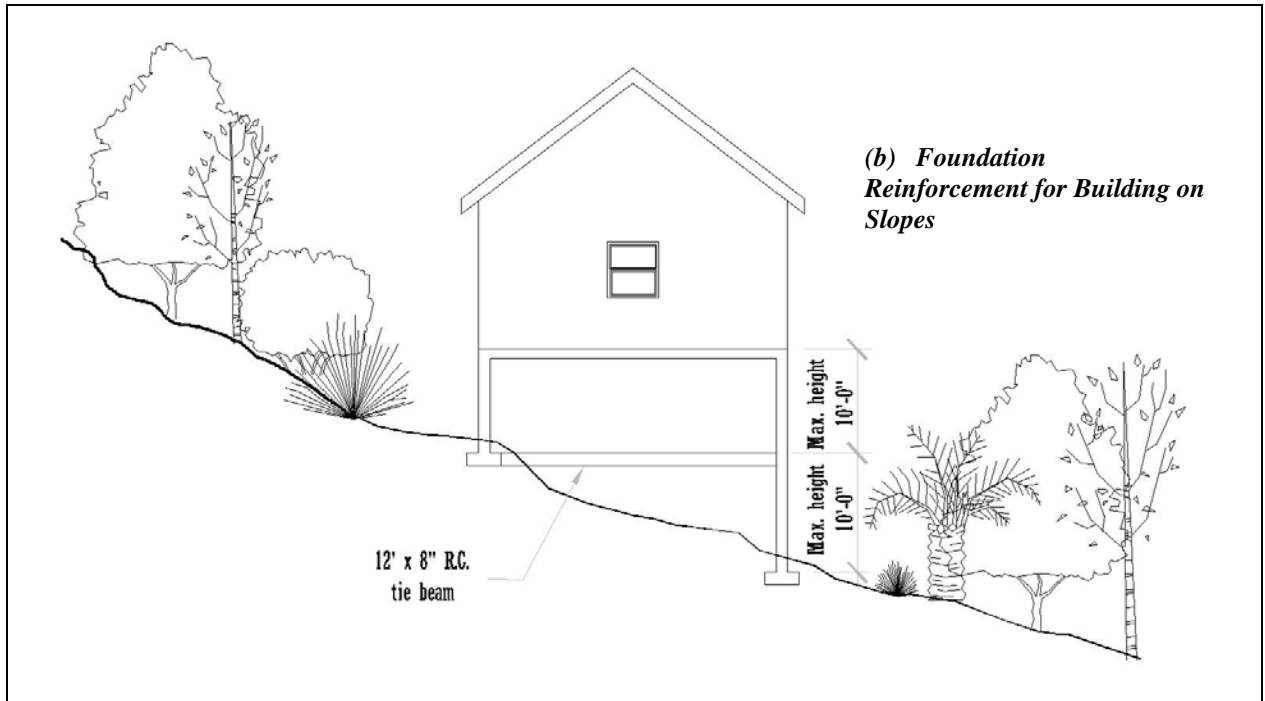
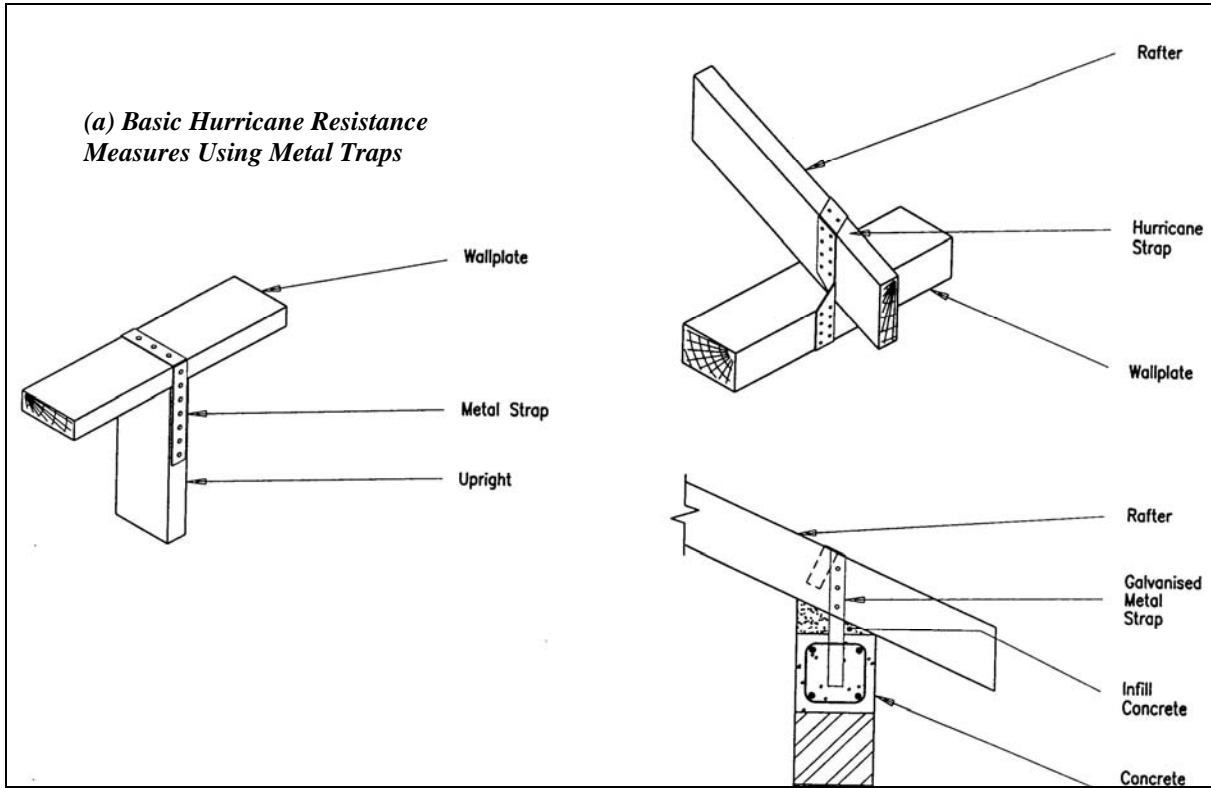

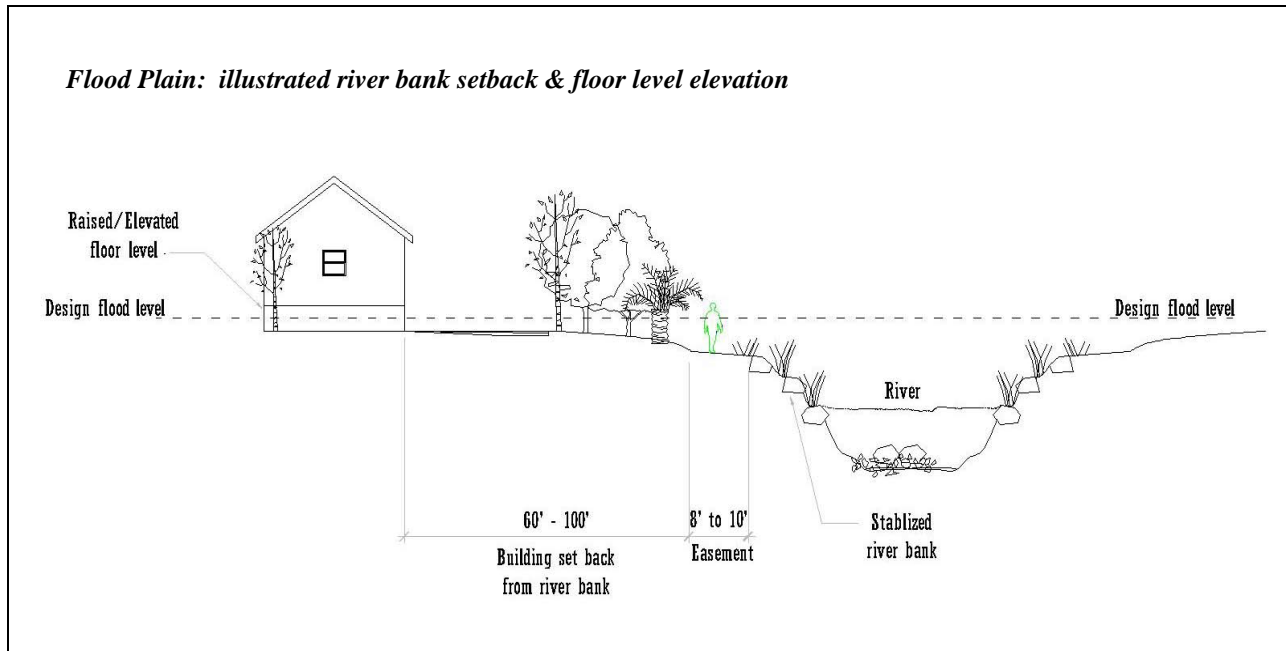

Source: ECLAC mission

**(d) Enforcing enabling planning legislation and regulations**

Table 74 lists a number of planning and sectoral issues, along with actions or responses to reduce vulnerability to wind, flood and landslide hazards. Responses are relevant to new developments or to existing uses that could benefit from retrofitting. Compliance with standards can be set as conditions at the time of planning approval. However, a significant, but undetermined, number of homes are being constructed without approval. This includes homes built by families, with joint ownership of large parcels, who avoid applying for development permission to save surveying and related costs associated with obtaining title to building lots.

Illegal development is also an issue for several initiatives that require planning approval, which does not happen in practice. Development as defined by the Physical Planning and Development Act encompasses "...the laying of roads, laying of water pipes, the clearing or leveling of land, the filling of ravines and swamps, the construction of any building.." or preparatory works which can be interpreted as improving the land or increasing its value.

The law also specifies that engineering, mining in, over or under land in relation to buildings, land subdivision, agriculture, forestry, advertising, and accumulation of derelict vehicles, scrap metal, refuse, spoil, or sludge which involves a material change in the land, constitute development. Effective enforcement for some of these uses may be unrealistic and the relevance of so doing should be evaluated as part of an ongoing review of the law.

**(e) Changes needed to mortgage and insurance policies**

The Saint Lucia Insurance Council (SLIC) revealed that its members do not generally offer incentives to policy holders who construct or retrofit buildings aimed at increasing resistance to hurricanes and floods. In at least one country of the OECS, discounts are given on premiums for property insurance to policy holders who construct or retrofit homes for hurricane resistance. It was reported that the cost of insurance is not differentiated for buildings constructed in hazard prone areas. Similarly, it is understood

that banks are not generally inclined to factor in hazard risks to buildings in evaluation of applications for mortgage loans.

SLIC, however, said it is taking steps to incorporate hazard risk analysis in pricing premiums and requested hazard maps from the Physical Planning Section and DCA. This is an important step that should be encouraged. The private sector's involvement is critical to broadening the scope of effort needed to reduce the vulnerability of the country resulting from the location and existing building design and construction practices.

The creation of a public/private sector task force with a mandate to explore options for using insurance and mortgage policies to effect change in building practices, leading to vulnerability reduction is recommended. The task force should have an appropriate mix of private and public sector representation to include SLIC, the Association of Bankers, the Physical Planning Section, DCA, Association of Engineers, NEMO, Ministry of Housing.

**(f) Making effective use of instruments and procedures for hazard impact mitigation**

Approaches to risk and vulnerability reduction in the OECS rely in part on instruments and procedures, such as EIAs and shorter, less intense or extensive Environmental Impact Statements (EIS), Social Impact Assessments (SIA), audits of facilities and services, risk assessments, among others. Damages and losses from Tomas highlight the need for: (a) Redrafting of generic terms of reference and scope for various assessments to fully incorporate hazard related risk and vulnerability analysis, (b) Widening the range of development activities subjected to impact assessment to include large residential subdivisions, agriculture, housing and infrastructure, and (c) Devising cost effective and simplified ways to undertake rapid hazard risk and vulnerability audits of essential services and buildings, farms on steep slopes, bridges, roads and power plants.

## **VI. CONCLUSIONS AND RECOMMENDATIONS: BUILDING RESILIENCE TO ADVANCE SUSTAINABLE LIVELIHOODS AND DEVELOPMENT**

The population of Saint Lucia, as that of other Caribbean island States, is in a position of increased vulnerability to the effects of climate change. Caribbean scientists and their global counterparts predict higher temperatures, rises in sea level, and increased hurricane intensity which will threaten lives, property and livelihoods throughout the subregion.

The nature of small island States and the patterns of development which heighten human activity in coastal zones and mountainous regions, means that more people and more income-earning activities may be located in vulnerable areas. Such a scenario could result in more people having more to lose in the event of a disaster. It would be true to conclude that in the Caribbean, the value of assets and population at risk has increased. The World Bank notes that disaster risk reduction has become one of the most important components of sustainable development.<sup>23</sup> If no action is taken to reduce risk, increased damage from tropical cyclones or hurricanes could result in increased loss of life, loss of tourism revenue, loss of livelihoods for the subregion's people and damage to capital assets and infrastructure,<sup>24</sup> reversing hard earned development gains.

Climate variability, as manifested by changing and unpredictable weather patterns, already represents a major challenge for planners in the subregion. Disasters, such as storms, hurricanes, floods and droughts have devastating effects on people's livelihoods, particularly those dependent on agriculture and tourism. The scope of response in adapting to and mitigating the effects of climate change and variability requires more integrated processes. Specifically, it requires the integration of adaptation and mitigation policies into development planning processes as risk-informed land planning and development policies are essential. Saint Lucia, as is evident from the experiences from Dean and Tomas, demonstrates that some resilience exists against the wind forces stemming from hurricanes at category 1 or 2. Hurricane Tomas has suggested, however, that the country continues to be vulnerable to high levels of precipitation.

The key action necessary for effective adaptation to climate change, mitigation and risk reduction is the delivery of coherent national development plans that seek to address the new challenges. This report, therefore, provides a series of recommendations which can be implemented at the national and community levels and across sectors. In addition, the recommendations speak to institutional, legal and policy mechanisms that could be developed or strengthened.

To advance Saint Lucia's capacity for reconstruction and long-term development in the aftermath of Hurricane Tomas, the following recommendations are proffered. For ease of reference recommendations are presented in two categories for implementation: (a) by the sectors to which they refer, and (b) by period of implementation i.e. short, medium and long term. Recommendations offered very often represent cross cutting issues and, therefore, reference to them may be found in a number of sectors. Although in the sectoral discussion recommendations are slightly fleshed out, they are meant only to act as a guide for public policy, programme and project development. It is expected that the authorities will use the recommendations to inform the development of specific projects based on government's priorities for rehabilitation, reconstruction and mitigation against future hazards.

---

<sup>23</sup> Integrating Disaster Risk Reduction and Climate Adaptation in the Fight against Poverty. Annual Report 2010. GFDRR.

<sup>24</sup> The Caribbean Community Climate Change Centre, <http://www.caribbeanclimate.bz/>

## **A. RECOMMENDATIONS BY SECTOR**

### **1. MACROECONOMIC FRAMEWORK**

Hurricane Tomas has complicated economic management for the Saint Lucian authorities. The economy was on a path to nascent recovery before the hurricane with a rebound in growth in tourism and an improvement in the balance of payments current account in the first half of the year. Indications are that unemployment also eased with the pick-up in activity. On the downside, the fiscal situation remained a challenge, as the deficit expanded, leading to higher levels of debt. Although debt levels are not yet deemed to be unsustainable, at over 75% of GDP, public sector debt could have quickly become unsustainable without corrective measures. In recognition of this, the government had embarked upon measures to ensure medium-term fiscal and debt sustainability, a key plank of which is tax reform, including plans to introduce the VAT and strengthened expenditure management. This, government expects, will yield a primary surplus of 1.5% to 2% of GDP in the medium term, providing some savings that can be invested in development infrastructure.

Hurricane Tomas now means that policy will have to change course in the short term. Instead of consolidation, the authorities will now have to relax the fiscal stance, in order to rehabilitate and rebuild the dam, the transport system and other infrastructure that are vital both to productive activity limiting social distress faced by citizens. It is, therefore, recommended that the authorities seek to leverage, as much as possible, any grant and concessional finance that might be available from the international community to contribute to the rehabilitation and reconstruction process. In this regard, emphasis should be placed on the development spillover from grants for the rehabilitation of infrastructure. The international community needs to partner with Saint Lucia as far as possible, given the constraints of the present global economic environment, to facilitate reconstruction investment to return the economy to trend growth.

Bilateral and multilateral creditors should consider debt restructuring, including one-off debt forgiveness for a portion of the debt owed to them, which could be earmarked against the rehabilitation of infrastructure or the rehabilitation of the agricultural sector. Such debt forgiveness will free up resources for the specific purpose of restoring the productive potential of the country, thereby providing a platform for growth and the future capacity of the country to service its debt. Indeed, significant vulnerability that was highlighted by the fallout from the hurricane underscores the multifaceted threats to sustained growth in small vulnerable economies, such as Saint Lucia. Therefore, international donors must be mindful not take Saint Lucia's upper middle income status as an indication that it does not need substantial assistance in the aftermath of such a disruptive disaster. Indeed, the very development gains, reflected in the achievement of middle income status are threatened by the heavy impact on development infrastructure and productive activity from hurricanes, such as Dean and Tomas.

It is also recommended that Saint Lucia be provided some space for contracting necessary debt on as favourable terms as possible to fully restore its water supply and productive infrastructure in order to ensure that the country is fully open for business for the remainder of the tourism season, in particular, so as to contain the number of cancellations and visitor spending in the sector. Tourism was on a recovery phase prior to the hurricane, and Saint Lucia would want to do all it can to contain fallout in the sector. Moreover, the productivity of such debt could be deemed high, as it would be readily translated into productive investment in the restoration of economy, thereby acting as a down payment on future growth. The only requirement is that authorities provide for the containment of growth in debt when the economy recovers, even using future boom time savings to pay off portions of the debt. This, buttressed by the implementation of the VAT and other revenue generating measures would put the fiscal situation on a sustainable path.

Crucially, the rehabilitation and reconstruction effort should strike a careful balance between reconstruction of physical infrastructure and the revitalisation of the affected productive sectors, especially tourism, agriculture, manufacturing and commerce. This means that, even as the government embarks on its major infrastructure rehabilitation programme, it will need to promote a business climate that encourages the private sector to reinvest in their operations to get them up and running as quickly as possible. It is anticipated that especially in the case of small farmers, manufacturers and retailers, some means-tested financial incentives might be necessary to catalyse their speedy recovery.

Disasters often present opportunities for making hard reforms and changes. Apart from building back infrastructure to a higher level of resilience, the fallout from Tomas should be used to implement policy measures to strengthen the economy, especially to take better advantage of the return to trend growth in major markets. A major drive should be made to improve the tourism product by markets in the first place, encouraging damaged properties to undertake upgrading work in the reconstruction plans, including expansion of capacity, where necessary. In addition, a major product/service upgrade should be undertaken in the sector, including careful branding in different segments of the marketing. This would enable Saint Lucia to continue to attract high-end visitors, but also to attract more Caribbean visitors by offering more affordable, medium-range packages. This could better diversify the tourism product by markets, thereby reducing its vulnerability to shocks in major Organization for Economic Cooperation and Development (OECD) markets. In addition, the time is also right to implement a strategy to achieve sustained airlift into the island to ensure high occupancy levels.

A major environmental resuscitation programme will also be required to restore and upgrade damaged nature trails and other natural assets. Targeted project proposals should be drafted for key components of this rehabilitation programme and should be presented to donor agencies with interest in this area.

## **2. GEO-ENVIRONMENTAL CONSEQUENCES**

(a) Given the unusual nature of this hydrological event (1:180 year storm) and the ensuing damage to the geo-environment, particularly in the areas of Barre de L'Isle, Guesneau, Colombette and Migny-Fond St Jacques, it is recommended that these areas be mapped and investigated in detail. Such investigations should include: topographic mapping of the paths and extent of the slides, geotechnical site investigations (borehole and/or geophysical) of the subsurface soils/rock and hydro-geological horizons, with appropriate integrated modeling and analysis of the failure mechanisms and modes.

(b) There exist landslide hazard assessments and maps of Saint Lucia, however, these appear to be done using data on a scale too large to be useful to small communities and single family initiatives. This is particularly so in the context of resettlement of communities emerging out of agricultural development. An example of an urban environment would be the Bagatelle Guesneau, Babonneau areas and a rural community, Fond St Jacques. The landslide hazard maps for the Greater Castries areas to the east of Castries indicate moderate to low susceptibility, suggesting that the mechanisms of failure are not captured within the current schemes.

(c) Although the historical landslide in the Ravine Poisson area in 1938 resulted in loss of life with the slide occurring over a relatively large area, the landslide hazard map for this area classifies the risk as moderate to low. This underscores the inability of such maps to represent data on the local scale, where event analysis would be more meaningful.

(d) This observation suggests that micro-zonation projects should be undertaken to revise the risk mapping at a smaller scale (tens of metres), with more sophisticated rainfall intensity infiltration models using either deterministic and or probabilistic methods. Such models would more accurately

capture local land use, topographic, soil, climate and hydro-geological data on a local scale and analyze the interaction of these in a site specific manner.

(e) A decision must also be made on the level risk the government and its people are willing to take in the mitigation against extreme events. In the context of earthquake risk, many Caribbean territories followed the United States practice in the 1970s in designing buildings to a 1 in 475 year return period of damaging event (10% probability of exceedance in a 50-year design life), then upgrading in 2000 to a 1 in 2500 year event (2% probability of exceedance in a 50-year design life). However, many countries/States/communities are finding these risk levels onerous to maintain and are contemplating more realistic risk levels.

(f) Update the existing landslide inventory with locations and size of the slide area, both later and axial lengths of slide.

(g) Record characteristics of storm events not only in terms of their rainfall, but also the rainfall intensity and storm duration.

(h) Update landslide hazard maps through data gathering on a smaller/human scale (tens of metres as opposed to hundreds of metres). The approach is akin to taking more survey points in areas of rapid gradient changes in order to represent the true nature of the ground. This data gathering at a smaller scale can be staggered or made discontinuous, over the island, where smaller scales are used to capture data in populated areas and larger ones are used in the virgin forested areas in a much larger scale. This would also apply to areas where any parameter changes significantly over small distances such as slope, soil type, geology.

(i) Carry out micro-zonation exercises in populated areas or in areas that are expected to be populated. Such studies are akin to smaller scale hazard mappings, where changes in topography, soil type, geology, hydrogeology, vegetative cover are characterized over tens of metres. Such studies would include landslide/mass movement susceptibility based on integrated rainfall-infiltration-stability analyses on actual topography and with site-specific climatic data. Such climatic data would include the transient characterization of tropical climates, rainfall-evapo-transpiration-moisture balance scenarios, as they relate to site-specific quantification of event risk.

(j) Characterize risk through either deterministic and/or probabilistic approaches, to facilitate a clearer understanding of the risks that can be financed and insured at an appropriate level to our island economies and preferred ways of living.

(k) Develop an engineering soils map of Saint Lucia, which would better represent the parameters that facilitate stability and water movement algorithms in climate-soil-interaction models. This can be done by investigating the depths and engineering soil properties, of the agricultural groups such that the existing series can be annotated with engineering characteristics of strength and hydro-geological parameters. A project of this type can be carried out regionally, in the volcanic island States (OECS), Grenada to Anguilla, where volcanic terrains predominate and are essentially similar in character.



### **3. INFRASTRUCTURE**

#### **(a) Water**

1. The section of pipeline from Junction Tank to Vanard in the north represents a potential weak link in the sustainability of water supply to the largest customer base in Saint Lucia (80%). As a result, it is recommended that either some measure of redundancy be built into this system, through the installation of a second pipeline, or the problems that have plagued this section of line be resolved in a proper and comprehensive manner at the earliest possible opportunity.

2. The water treatment and distribution system in the south, specifically for Vieux Fort, needs to be revamped and updated, as required.

3. A bathymetric survey of the Roseau Dam should be commissioned immediately, to quantify the levels of sedimentation that have occurred in the dam as a result of Hurricane Tomas.

4. Following the quantification of sedimentation volumes, a suction dredge should be employed to remove the sediment from the dam. This dredged material should then be stockpiled in a location that will not create further geotechnical instabilities.

5. Some measures of slope stability need to be employed on the slopes of the mountains that surround the dam.

#### **(b) Electricity**

1. Relocation of the Union Substation to a location beside its existing position, on slightly higher land. Experience from Tropical Storm Debby in 1994 showed that this station is vulnerable to flooding.

2. Elevation of the critical infrastructure in the relocated Union substation by approximately 1 metre above floor level.

#### **(c) Telecommunications**

1. Based on observations from recent disasters in the subregion, it is becoming increasingly clear that the use of cellphones can assist significantly in post-event rescue and recovery scenarios, in helping to locate individuals who may have been cut off from their communities, and in assisting ongoing communications with family, friends and the outside world during an event. This underscores the relevance of this subsector in restoration efforts.

2. One point that was raised by the Digicel management team was that the Government of Saint Lucia has not offered any concessions to the industry for equipment replacement. It was proposed that the granting of duty-free concessions after a disaster event be considered by the Government of Saint Lucia, to assist in the rehabilitation process.

#### **(d) Sea and airports**

1. A review of the airport/runway drainage to be carried out, with the objective of reducing runoff of water and mud to the runway during a high rainfall event.

**(e) Transportation - Roads and bridges**

1. Bridge structures for major rivers should be designed to pass at a minimum the 1 in 50 year flood event.
2. The existing bridges should be replaced with open span structures, so that their waterway areas are greatly maximized. Proper design of wing walls should be incorporated into the design

**(f) River training**

1. In order to properly assess the floodplain areas for the affected rivers, it is first necessary to carry out hydraulic and hydrological analyses for the 1 in 25, 50 and 100 year return period events.
2. Once these investigations have been completed, then hazard mapping can be carried out and, where necessary, relocation of affected housing and settlements should be carried out in an informed manner.

**4. THE AGRICULTURAL SECTOR**

Development and implementation of an agricultural land use and water management plan to include policy, measures and actions for implementation, such as:

**(a) Policy measures**

1. Enabling legislation to prohibit inappropriate land use and the means to enforce regulations.
2. Incentives and inducements to attract farmers out of cultivation on steep hillside lands, especially the promotion of alternative forms of livelihood.
3. Enforcement of regulations to preserve forest or cultivate permissible tree crops in determined buffer zones alongside rivers.
4. Reforestation of steep hillside lands taken out of cultivation, with special emphasis placed on the selection of the appropriate deep-rooting tree species.

**(b) Actions to be implemented**

1. Conduct flood and drought mapping of lands within specific watershed areas, including the lands suitable for agriculture within these areas.
2. Identification of land use pattern and compatibility with recommended land and soil management practices, e.g. land capability classification vs. existing land and agricultural management practices.
3. Adoption of an integrated development planning approach to manage the watershed areas.
4. Promotion and sharing of watershed management best practices as a means of ensuring sustainable land/soil management practices.
5. Creation of more opportunities to increase off-farm earnings.

6. Discourage farming on marginal lands.

### **5. FORESTRY**

Restore the government forest reserve lands through a series of actions, to include:

- (a) Reforestation of natural forest areas which have suffered from major landslides and slippage, including forest edges that have been destroyed. Approximately, 365 acres of lands will be reforested.
- (b) Stabilization of landslide areas through direct seeding, planting of natural wildlings, bio-engineering techniques.
- (c) Clearing of large openings by removing debris and, creating the conducive environment to allow for natural regeneration of natural tree species.
- (d) Planting of suitable fruit trees to provide food sources for the wildlife species, in particularly the avifauna.
- (e) Encouraging farmers operating on moderate slopes with suitable soils to substitute deep-rooting tree crops such as cocoa, mango, citrus, etc., for shallow rooting bananas and root crops.
- (f) Reforestation of plantation forests, after salvaging all possible timber with economic value.
- (g) Reforestation of private forests, buffer stripes, forest corridors and all forest edges.
- (h) Reforestation of all important woodland areas, particularly those lands that are important for wildlife protection and management,
- (i) Stabilization of all critically important private lands both forested and non-forested that are adjacent to the government forest reserves.
- (j) Rehabilitation of trails and other ecotourism facilities; restoration of riparian vegetation along major rivers island wide.
- (j) Restoration of forest reserves boundary lines.

### **6. THE TOURISM SECTOR**

- (a) Revamp the implementation/management aspects of the Hospitality Sector Crisis Management plan with a view to enhancing its effectiveness and promoting more efficient coordination between the public and private sectors, particularly in respect of information dissemination, warning alerts, preparation, mobilization and response.
- (b) Improve the enforcement aspects of planning and construction standards by either imbuing the DCA with a more independent and stronger legal fiat for enforcing building codes or establishing an independent body whose sole responsibility would be to monitor, assess and enforce building standards and planning laws. In essence, the current practice of ministerial review and ministerial veto of planning guidelines should be abolished forthwith.

- (c) Amend the Development Control (Planning) Legislation to mandate the inclusion of:
  1. Energy efficient fixtures and fittings.
  2. Efficient water-use fixtures/installations and adequate water storage facilities.
  3. Ample reserved green spaces and clear evidence of a net contribution to the greening of Saint Lucia in all new building applications, particularly for large projects in the tourism sector.
- (d) Provide fiscal incentives and legislative reform to facilitate the retrofitting of energy and water-use efficient installations in existing structures.
- (e) Facilitate the use of alternative water sources such as desalination and ground water supplies, and
- (f) Encourage and facilitate the orderly development of water taxis for both locals and visitors. This would not only widen the transportation options and provide a viable and scenic option to traditional road transportation but would allow a viable alternative in the event of road congestion and closures as a consequence of natural disasters, industrial action, emergency road works, among others.

#### **7. THE ENVIRONMENT, WITH PARTICULAR EMPHASIS ON WATER**

- (a) Strengthen processes for de-silting rivers and develop a de-silting and maintenance programme including examination of possible uses of the extractive materials and combine this with the strengthening of programmes for riverbank stabilization and restoration.
- (b) Strengthen the programme of river defenses and slope management for the most vulnerable areas using natural and engineering solutions, including the enforcement of buffer zones between development areas and forests and between development areas and river banks. In this context, development zones include agriculture.
- (c) Develop a national rain harvesting programme and review water production alternatives to reduce the dependency on a single source of supply.
- (d) The debris from the mass movements of soils that occurred in Dominica during hurricane Dean in 2007 has been successfully used for construction purposes in that country. It is recommended that similar alternative uses be found for the extracted materials in Saint Lucia
- (e) Strengthen the safeguarding of the benefits of biodiversity and establish a programme for the monitoring and assessment of the nation's coral reefs and a monitoring and assessment programme for priority wildlife resources and critical watersheds
- (f) Ensure that commercial banks and credit unions establish programmes for incentives and disincentives for developments that contravene setback and buffer zone regulations or are located in areas that are unsuited for the proposed development.

## **8. THE SOCIAL SECTORS**

(a) In regard to community redevelopment it will be important in the planning for the reconstruction of Fond St. Jacques, for the use of micro-zonation techniques to take place. These should include:

1. Stabilisation of slopes above settlements
2. Redefine the water course
3. Relocate vulnerable persons from selected plots to safer areas within the community
4. Establish zones for built and natural areas
5. Establish standards for built environment and farming
6. Ensure that participatory rapid assessments inform the planning processes

(b) Provide special incentives to increase the participation of youth and females, particularly those who are heads of households, in sustainable livelihoods process – through micro lending facilities and small grants.

(c) Facilitate the development of early warning systems for community management and response.

(d) Review social safety net programmes to ensure that those most affected due to the devastation caused by Hurricane Tomas are given priority to receive the necessary support to reduce family instability and dysfunctional behavior.

(e) Establish a small grants/loan mechanism to support restoration and reconstruction of damaged housing with mitigation in essence to allow owners to build back better.

(f) Undertake repair and reconstruction of schools and health facilities damaged by Hurricane Tomas and develop a plan for retrofitting those public buildings requiring such, so as to reduce negative impacts before the next hurricane season.

(g) Offer incentives which would encourage private home owners to retrofit their buildings against land slips and slides, before the next hurricane season.

(h) Strengthen disaster management and communication capacity at the micro, meso and macro levels including, and especially, through the strengthening of baseline information systems especially statistical systems, in post disaster situations so as to enable the production of timely and useful data.

(i) Develop and disseminate hazard and risk information at the community level so that members of the community can act in their own defense.

(j) Improve land development practices, processes and cultural practices which clear land of all vegetation before construction or the planting of new vegetation begins.

(k) Strengthen and develop public education and community education programmes which seek to address the flaws in long standing cultural and development practices that do not take into account the intrinsic vulnerabilities of Saint Lucia

### **9. DATA MANAGEMENT AND MAPPING TOOLS**

Consultations with stakeholder agencies and professionals reveal a number of critical issues that must be resolved in relation to data management, planning and development control:

(a) Updating of existing hazard maps, which are not adequate for site specific analysis of hazard risk for planning and development control.

(b) Development of a National GIS, for management of spatial data in support of planning, risk and hazard analysis, and development control.

(c) Additional Resources to build capacity at the Physical Planning Office for the preparation of National Plans and for Monitoring and enforcement of land development and building to ensure compliance with land development and building approval.

(d) Training of staff to meet the administrative and technical requirements of the Physical Planning Section.

## VII. RECOMMENDATIONS - B: PERIOD OF IMPLEMENTATION

It is recommended that the government may:	Short-term	Medium-term	Long-term
<b>A:</b>			
(i) Elaborate a National Recovery Plan, to be executed through a special unit within the Economic Planning Unit of the Ministry of Finance, Economic Affairs and National Development and implemented at the sectoral level;	←→		→
(ii) Seek debt restructuring, including one-off debt forgiveness for a portion of their debt ;	←→		
(iii) Engage in topographic mapping of the severely affected areas such as Barre de L'Isle, Guesneau, Colombetter and Mingy-Fond St. Jacques;	←→		
(iv) Develop Micro-zonation projects to revise the risk mapping at a smaller scale in key areas of the country especially in the Fond St. Jacques Community;	←→	→	
(v) Develop a measure of redundancy regarding the section of the pipeline from Junction Tank to Vanard;	←→		→
(vi) Undertake a bathymetric survey of the Roseau Dam;	←→		
(vii) Undertake slope stability on the slopes of the mountains that surround the dam;	←→		
(viii) Employ suction dredge to remove the sediment from the Roseau Dam;	←→	→	
(ix) Undertake slope stability on the slopes of the mountains that surround the dam;	←→	→	
(x) Undertake the river de-silting, clearing and bank strengthening in priority river basins, including Cul de Sac, Roseau, Dennery and Soufriere;	←→	→	
(xi) Explore alternative uses for the debris from the siltation of rivers and dams and from the mass movements of slopes;	←→	→	
(xii) Provide special incentives to increase the participation of youth and females particularly those who are heads of households, in sustainable livelihoods processes;	←→		
(xii) Relocate the Hospital in Dennery;	←→		

(xiv)	Establish a small grant/loan mechanism for low cost housing repair and reconstruction;	←→		
(xv)	Review existing safety net programmes with a goal of ensuring support is provided to those most affected by the devastation caused by Hurricane Tomas;	←→		
(xvi)	Refurbish schools and health centres that were damaged by Hurricane Tomas;	←→	→	
(xvii)	Revamp the implementation/management aspects of the Hospitality Sector Crisis Management plan;	←→	→	
(xviii)	Improve the enforcement aspects of planning and construction standards;	←→	→	
(xix)	Provide fiscal incentives and legislative reform to facilitate the retrofitting of energy and water-use efficient installations in existing structures; and	←→	→	
(xx)	Monitor near shore environments for increased sedimentation.	←		→
<b>B:</b>				
(i)	Seek to shift its response to risk reduction from purely an environmental response, or from purely a project based response, to a wider and deeper national development response. A response that is anchored in national development planning, including physical planning and budgeting procedures;	←		→
(ii)	Promote business climate that encourages the private sector to reinvest in their operations;		←→	→
(iii)	Explore means-tested financial incentives as is necessary to catalyze the speedy recovery of small farmers, manufacturers and retailers;	←→	→	
(iv)	Update the existing landslide inventory;	←→	→	
(v)	Record characteristics of storm events differently;	←→	→	
(vi)	Update landslide hazard maps through data gathering;	←→		→
(vii)	Conduct micro-zonation exercises in populated areas or in areas earmarked for development;		←→	→
(viii)	Relocate the Union Substation and elevation of its critical infrastructure;	←→	→	
(ix)	Consider the granting of duty-free concessions after a disaster for damaged or destroyed telecommunications equipment;	←→	→	



(x) Reduce runoff of water and mud to the airport runway through enhanced drainage techniques;	←	→	
(xi) Replace existing bridges with open span structures;		←	→
(xii) River training exercises should follow the conduct of hydraulic and hydrological analyses on the floodplain areas for affected rivers;		←	→
(xiii) Undertake flood and drought mapping of lands within specific watershed areas;		←	→
(xiv) Undertake identification of land use patterns and compatibility with recommended land and soil management practices;		←	→
(xv) Promote and share best practices in watershed management;	←	→	
(xvi) Create additional opportunities to increase off-farm earnings;		←	→
(xvii) Discourage farming on marginal lands;		←	→
(xviii) Undertake measures to Restore Government forest reserve lands;	←	→	
(xix) Increase public education and information campaigns to reduce risk;		←	→
(xx) Establish programmes for monitoring and assessing the nation's coral reefs (fisheries) and wildlife resources (forestry);		←	→
(xxi) Consider disincentives for development that contravenes the setback and set up regulations;		←	→
(xxii) Strengthen disaster management and communication capacity at all levels in the society;		←	→
(xxiii) Develop and disseminate hazard risk information at the community level;		←	→
(xxiv) Improve land development and practices;		←	→
(xxv) Facilitate the development of early warning systems;		←	→
(xxvi) Amend the Development Control (Planning) Legislation;		←	→
(xxvii) Encourage and Facilitate the use of alternative water sources; and		←	→

(xxviii) Encourage and facilitate the orderly development of water taxis for both locals and visitors.		←	→
<b>C:</b>			
(i) Embark on major environmental resuscitation programme to restore and upgrade damaged nature trails and other eco tourism products;	←		→
(ii) Undertake study to characterize risk;	←		→
(iii) Articulate government policy on the level of risk willing to be absorbed by the society in the construction of infrastructure;	←		→
(iv) Develop an engineering soils map of Saint Lucia;		←	→
(v) Revamp and update the water treatment and distribution system in the southern part of the country; and		←	→
(vi) Develop and implement a land use and water management plan including watershed management		←	→

## Annex I

**Table 74: Mitigation actions and responses to vulnerability issues**

Issues	Actions/Responses	Targeted Hazards			Timing of Response	
		Wind	Flood	Land Slips	New Developments	Retrofit Existing Uses
<b>Effective Application of Plans, Instruments and Procedures</b>						
	<ul style="list-style-type: none"> <li>Commission Strategic Plans for Vulnerable Areas</li> </ul>					
	<ul style="list-style-type: none"> <li>Widen the scope of EIAs/EISs/SIAs for risks and vulnerability assessment of Hazard Impacts</li> </ul>					
	<ul style="list-style-type: none"> <li>Use Risk and Vulnerability Audits for Essential Buildings, Services, Farms, Utilities &amp; Infrastructure</li> </ul>					
	<ul style="list-style-type: none"> <li>Subject Residential and Mixed Use Land Subdivision Projects to Vigorous Scrutiny for Environmental &amp; Hazard Impacts</li> </ul>					
	<ul style="list-style-type: none"> <li>Develop a National GIS for Data Collection &amp; Analysis</li> </ul>					
	<ul style="list-style-type: none"> <li>Update Hazard Maps with Broad-base Access &amp; Use</li> </ul>					
<b>Surveillance, Monitoring, Enforcement</b>						
	<ul style="list-style-type: none"> <li>Build Administrative and Technical Capacity of Physical Planning Section (PPS): Hire &amp; Train Staff</li> </ul>					

Issues	Actions/Responses	Targeted Hazard			Timing of Response	
		Wind	Flood	Landslip	New Development	Retrofit Existing Uses
	<ul style="list-style-type: none"> <li>Review and update Building Codes; insert additional Relevant Standards for Hurricane, Floods, Landslips, Erosion Control on Slopes &amp; River Banks, Storage of Hazardous Substances</li> </ul>					
	<ul style="list-style-type: none"> <li>Strengthen Collaborative Mechanisms between the PPO and other Regulatory Agencies or Bodies with Mandates for Hazard Related Damage and Loss Mitigation</li> </ul>					
	<ul style="list-style-type: none"> <li>Craft a Practical and Realistic Procedure to Achieve Compliance of Statutory Corporations &amp; Government Agencies with Development Approval Requirements</li> </ul>					
	<ul style="list-style-type: none"> <li>Devise Strategic &amp; Cost Effective Plans for Execution of Monitoring &amp; Enforcement Tasks in Various Enforcement Districts</li> </ul>					
<b>Standards &amp; Guidelines for Building Design &amp; Construction: Houses, Schools, Hotels, Other Structures</b>						
	<ul style="list-style-type: none"> <li>Use a Variety of Hurricane Resistant Metal Straps and Clips, to Reduce Damage and Loss, Examples:</li> </ul>					

Issues	Actions/Responses	Targeted Hazard			Timing of Response	
		Wind	Flood	Landslip	New Developments	Retrofit Existing Uses
	<ul style="list-style-type: none"> <li>Bolted Connection of Walls to Foundation; Strap Rafters to Wall Plate</li> </ul>					
	<ul style="list-style-type: none"> <li>Use Hip or Gable Roofs in Preference To Flat or Lean-to Designs; Replace Flat Roofs Depending on Affordability</li> </ul>					
	<ul style="list-style-type: none"> <li>Pitch non-concrete roofs to &gt;30° and reduce overhang to &lt;1ft</li> </ul>					
	<ul style="list-style-type: none"> <li>Use shutters to protect glass doors, windows and other openings; use Strong Hinges &amp; Fasteners</li> </ul>					
	<ul style="list-style-type: none"> <li>Use corner bracers (metal) on wooden buildings</li> </ul>					
	<ul style="list-style-type: none"> <li>Devise no-build policy for extreme hazard zones; set strict standards for bldg in other hazard zones</li> </ul>					
	<ul style="list-style-type: none"> <li>Setback building or other structure for a minimum of 60 ft from river banks, as required by the DCA</li> </ul>					
	<ul style="list-style-type: none"> <li>Set ground floor level of buildings above historic or professionally calculated flood levels</li> </ul>					

Issues	Actions/Responses	Targeted Hazard			Timing of Response	
		Wind	Flood	Landslip	New Developments	Retrofit Existing Uses
	<ul style="list-style-type: none"> <li>Use a storm drainage system designed or approved by an engineer, as required by the DCA for large projects or difficult sites; or other experienced professional for smaller structures</li> </ul>					
	<ul style="list-style-type: none"> <li>Storm drainage systems for major subdivisions should take into consideration anticipated or allowed maximum building coverage on the lot to include the footprint of buildings, plus all other impervious surfaces; if rainwater is not to be harvested from the buildings, this should also be factored into runoff calculations</li> </ul>					
	<ul style="list-style-type: none"> <li>Seek to reduce volume of runoff from the property and channel flow to a natural watercourse or river as appropriate</li> </ul>					
	<ul style="list-style-type: none"> <li>Regularly clean and maintain the constructed storm drains or natural drains on the property</li> </ul>					

Issues	Actions/Responses	Targeted Hazard			Timing of Response	
		Wind	Flood	Landslip	New Developments	Retrofit Existing uses
<b>Infrastructure and Utilities</b>						
	<ul style="list-style-type: none"> <li>Design a Phased Programme to Install Transmission Lines Underground to Reduce Damages and Losses Associated with Electricity Services; prioritize Lines Serving Settlements with large populations</li> </ul>					
	<ul style="list-style-type: none"> <li>Explore the Use of Reverse Osmosis and Desalination Technologies as Options to Meet Future Water Demands in Support of Existing Sources</li> </ul>					
	<ul style="list-style-type: none"> <li>Subject New Roads to Rigorous Pre-construction Assessment of Environmental, Risk and Hazard Impacts to Reduce Future Similar Damages and Loss to those of Tomas; Undertake Vulnerability Audits of Selected Roads and Bridges aimed at Retrofitting to improve Design and Construction Standards</li> </ul>					

Issues	Actions/Responses	Targeted Hazard			Timing of Response	
		Wind	Flood	Landslip	New Developments	Retrofit Existing Uses
<b>Public Amenities, Recreational Facilities</b>						
	<ul style="list-style-type: none"> <li>Establish Location and Design Parameters for Football and Cricket Field to Achieve Desired Drainage</li> </ul>					
	<ul style="list-style-type: none"> <li>Suggest Design and Construction Standards &amp; Specifications for Equipment, Various Public Amenities: Ball Courts, Public Parks, Pools, Street Furniture, Pedestrian Street Lights, Bus Shelters, etc</li> </ul>					
	<ul style="list-style-type: none"> <li>Undertake Cost Effective Vulnerability Audits of Sports Stadia and Introduce Cost Saving Maintenance Programs</li> </ul>					
<b>Sustainable Farming</b>						
	<ul style="list-style-type: none"> <li>Clarify the legal responsibility for regulating developments associated with farms and establish an appropriate procedure for approving farming development projects</li> </ul>					



Issues	Actions/Responses	Targeted Hazard			Timing of Response	
		Wind	Flood	Landslip	New Developments	Retrofit Existing Uses
	<ul style="list-style-type: none"> <li>Terrace slopes; alternatively use vegetation barriers interspaced between crop to contain soil and avoid loss of soil from the site</li> </ul>					
	<ul style="list-style-type: none"> <li>Promote Intercropping to establish ground cover</li> </ul>					
	<ul style="list-style-type: none"> <li>Train farmers in adaptation methods; and provide options on suitable crops for hillside farming</li> </ul>					
	<ul style="list-style-type: none"> <li>Strengthen Interagency Cooperation Between Land, Resource &amp; Disaster Management Agencies, for Slope &amp; Forest Protection</li> </ul>					
<b>Forest &amp; Environment Protection</b>						
	<ul style="list-style-type: none"> <li>Devise Effective Permit Procedure to Avoid Indiscriminate Vegetation Clearing for Housing and farming on slopes</li> </ul>					
	<ul style="list-style-type: none"> <li>Set Procedures for Soil &amp; Rock Excavation, and Soil Conservation Measures on Steep Slopes</li> </ul>					
	<ul style="list-style-type: none"> <li>Strict Enforcement of "Tree Orders" for protection of Plants in Areas Approved for Development</li> </ul>					

Issues	Actions/Responses	Targeted Hazard			Timing of Response	
		Wind	Flood	Landslip	New Developments	Retrofit Existing Uses
	<ul style="list-style-type: none"> <li>Strict Protection of Vegetated Areas Critical to Biodiversity Conservation</li> </ul>					
	<ul style="list-style-type: none"> <li>Restore Riparian Forests, where appropriate</li> </ul>					
<b>River Bank Protection</b>						
	<ul style="list-style-type: none"> <li>Enforce setbacks building/farming from river banks</li> </ul>					
	<ul style="list-style-type: none"> <li>Plant Tree Crops with Soil Stabilizing Root Systems along Sections of River Banks</li> </ul>					
	<ul style="list-style-type: none"> <li>River Training, to Restore Eroded River Banks</li> </ul>					
<b>Tourism</b>						
	<ul style="list-style-type: none"> <li>Enforce Building Setback and Minimum Elevation of Guest Room Floor Levels For Shoreline Buildings</li> </ul>					
	<ul style="list-style-type: none"> <li>Devise Standards for Location &amp; Operation of Back-of-House Facilities ; Set Minimum Elevations for Standby Generators, Sewage Treatment Plants</li> </ul>					
	<ul style="list-style-type: none"> <li>Select Facilities &amp; Sites for Storage &amp; Anchoring of Yachts &amp; Motorized Craft during Storms</li> </ul>					

## Annex II

**PROJECT TITLE:   ENGINEERING, PLANNING AND RETROFITTING OF  
INFRASTRUCTURE FOR THE RECONSTRUCTION OF THE  
FOND ST. JACQUES/MIGNY SETTLEMENT**

**Sector:               SETTLEMENTS AND INFRASTRUCTURE**

**BACKGROUND:** Because of extensive damages suffered during Tomas, the project seeks to address the short to medium term requirements for reconstruction of the Fond St. Jacques/Migny Settlement/Community to improve its resilience to future hazards

**Project objectives:**

(a)       To undertake geotechnical and civil engineering investigations to inform required interventions, such as slope stabilization and retrofitting of infrastructure to build resilience to landslips and flood related impacts

(b)       To investigate existing land ownership, tenure, demographic and related socio-economic conditions, important to the implementation of reconstruction strategies

(c)       To reach agreement on a landuse plan with distinctive build and no-build zones, using a process for community consultations and involvement

(d)       To provide estimates for agreed public infrastructure and amenities components of reconstruction and seek immediate implementation of the most critical projects

(e)       To effectively address and seek resolution to compensation and related issues that could result from decisions to abandoned lots in “harm’s way”.

**Duration of Services:** 1 year, with major hazard risk reduction initiatives taken before the start of the 2011 hurricane season

**National executing agency:** Ministries of Physical Planning, Works, Community Development, along with NEMO

**Description of activities and tasks:**

(a)       Geotechnical & Engineering investigations, demographic, socio-economic studies and landuse investigation by a Team, including a Geotechnical Engineer, Civil Engineer, Sociologist/Community Planner, Architect/Planner or Landscape Architect/Planner

(b)       Plan and implementation of a communications strategy for public understanding and support of reconstruction initiatives, including mitigation strategies to be adopted by households; this activity to be undertaken by a Communications Specialist

(c)       Preparation and presentation of Geotechnical & Engineering Drawings, Results of Demographic /Socio-economic studies, Physical Plan (showing build zones, no-build/natural zones, public amenities and circulation)

- (d) Costing of prioritized public infrastructure and amenities projects
- (e) Presentation of proposals to Government
- (f) Construction of agreed projects

**Expected results and products**

(a) The reconstruction plans (engineering and physical /landuse) are approved by Government and endorsed by the community

(b) Residents appreciate the need to adopt hurricane, landslip and flood resistance measures for new homes and existing properties where retrofitting is possible

(c) Residents with homes in “harm’s way” have agreed to abandoned properties and move to safer lots within the community

(d) Issues associated with compensation resulting from use restrictions and related matters are fairly resolved or in the process of being settled in fairness

- (e) Selected public infrastructure and amenities projects are implemented

**Total required investment (provisional estimate): US\$ 2.0 m**

**PROJECT TITLE: NATIONAL GIS SYSTEM AND DATA MANAGEMENT NETWORK FOR SAINT LUCIA**

**Sector: MULTI-SECTORAL**

**BACKGROUND:** Need for a centrally located, high quality digital map information repository or Geographic Information System (GIS) for the country.

**Project objectives**

- (a) To ascertain the status of digital information, data use, currency and gaps
- (b) To provide the necessary technical support and experience to select a cost effective option for a national GIS network infrastructure, equipment and procedures designed to suit St. Lucia's requirements for data gathering, storage, and sharing by and among key government agencies and corporations and selected non-government collaborating entities
- (c) To achieve realistic and appropriate designs for GIS infrastructure and network improvements and upgraded procedures relevant to the country's needs
- (d) To provide training to about 20 persons from various agencies in maintenance of the GIS network and in resolving major GIS data use issues such as compatibility between formats and map referencing systems
- (e) To establish national data standards, data exchange policies, including data sale, pricing, and copy writing

**Duration of services:** 2 years

**National executing agency:** Ministry of Physical Planning, with the collaboration other Selected Agencies and Government Corporations

**Description of activities and tasks:**

- (a) Comprehensive assessment of the status of digital information, use of digital data, training and equipment needs
- (b) Consultations with various stakeholders agencies and corporations to determine gaps/needs, and issues associated with existing practices in the gathering, management, use and sharing of GIS
- (c) Design of a Central GIS Repository, serving a network of agencies with their own data bases with responsibility for their upkeep and maintenance
- (d) Selection and sourcing of infrastructure components (hardware, software of the repository and network)
- (e) Training of staff from selected agencies and government corporations

**Expected results and products**

(a) Wide and broad-based use of GIS applications by agencies in hazard mapping, land use planning, settlement design, and spatial analysis of demographic and socio-economic data

(b) Highly trained GIS personnel in relevant Departments, Ministries and Government Corporations (example, Physical Planning, National Projects Unit, Statistics Department and Ministry of Agriculture)

(c) Functional GIS data bases in other offices

(d) Quick systematic response by the Survey and mapping Department to public requests for mapped information with aerial imagery overlaid with land ownership parcels, topographical and hydrological data

**Total Required Investment (provisional estimate):** US\$

**PROJECT TITLE: VULNERABILITY AUDITS OF ESSENTIAL FACILITIES****Sector: MULTI-SECTORAL****BACKGROUND:** Hurricane and flood damage to buildings from Tomas suggest the need for audits of facilities and infrastructure providing essential services**Project objectives**

- (a) To evaluate the vulnerability of selected facilities to natural hazards
- (b) To assess structural deficiencies, site conditions, location and other relevant factors affecting vulnerability to flood and storm force winds
- (c) To recommend retrofitting for hurricane and flood resistance based on audit results

**Duration of Services:** 2 years**National executing agency:** Ministry of Physical Planning, with the collaboration other Selected Agencies and Government Corporations**Description of activities and tasks:**

- (a) Commission audit team of relevant mixed professionals, including civil engineer, environmental planner or engineer, other specialists as required
- (b) Audit of the following:
  - 12 schools
  - 12 clinics
  - St. Nicholas Hospital
  - 12 bridges
  - 50 miles of roads
  - 4 hotels
- (c) Retrofitting of the following :
  - 6 schools with shutters or aluminum “school windows”, graded hurricane straps, and screws for galvanize sheets
  - 50 homes average size 1000 sq ft with hurricane straps and shutters

**Expected results and products**

- (a) Existing Conditions are known for audited facilities and infrastructure
- (b) Selected facilities and structures are upgraded to standards, making for improved resilience to hazards
- (c) The appropriateness and utility of the audits influence wider use of the techniques

**PROJECT TITLE: UPDATED AND IMPROVED HAZARD MAPS FOR SAINT LUCIA****Sector: PLANNING & DEVELOPMENT CONTROL**

**BACKGROUND:** Short-term need to update hazard maps prepared in response to various hazards between 1985 – 2007, with donor support, to assist land use, settlement planning, sector planning and enforcement of standards critical for the mitigation of hazard impacts.

**Project objectives**

- (a) To comprehensively map the footprints of landslide and other damages from Hurricane Tomas before the scars disappear
- (b) To determine gaps in the existing hazard maps portfolio
- (c) To produce the best possible quality maps by procuring high resolution satellite imagery for the country to use in their preparation
- (d) Categorization of hazard zones into extreme, high and moderate risks, using state-of-the-art technological models, as a guide to the approval and enforcement of development projects, costing property insurance premiums and evaluation of mortgage loans

**Duration of Services:** 1 year

**National executing agency:** Ministry of Physical Planning, with the collaboration of the National Emergency Management Office (NEMO)

**Description of activities and tasks:**

- (a) Detailed assessment of existing maps, adequacies and deficiencies
- (b) Consultations with stakeholders (Planning, development and disaster agencies, insurance companies and banks) so as to design map that fit local needs
- (c) Field observations, modeling and other technological applications in risk analysis
- (d) Public awareness and education using creative communications strategies
- (e) Training to build local capacity in hazard mapping, risk and vulnerability analysis
- (f) Development of a classification system for mapping hazard areas into extreme, high and moderate risk categories
- (g) Comprehensive mapping of landslip areas that occurred during Hurricane Tomas

**Expected results and products**

- (a) A comprehensive atlas of hazard zones in St. Lucia categorized by levels of risks into extreme, high and moderate risk zones, prepared and published for public use, targeting developers, engineers, architects, bankers, insurers, land owners



(b) Geo-referenced electronic GIS applicable files of data layers of factors used to determine levels of risks, for example, contours, slopes, soil type, vegetation, rainfall, hydrology, historic and calculated flood levels

(c) At least 20 persons from selected agencies trained in risk analysis and hazard impact mitigation principles and techniques

(d) Increased public awareness about hazard sites, measures to reduce risks to floods, landslides, appropriate responses to eminent and actual hazards, and evacuation procedures

**Total required investment (provisional estimate): US\$1.0 m**

**PROJECT TITLE: MULTI-STAKEHOLDER COLLABORATION IN REDUCING VULNERABILITY IN THE WATERSHED**

**Sector: MULTI-SECTORAL**

**BACKGROUND:** The Soufriere Watershed, like the Cul De Sac watershed, has a history of severe land slip and flood damage. An organized multi-stakeholder response to future threats from natural hazards to communities within its boundaries is needed by addressing the watershed as a hydrological unit.

**Project objectives**

- (a) To improve land use and building practices by removing barriers to the adoption of best practices
- (b) To reduce future risks to settlements through area planning that is informed by engineering solutions and mitigation strategies and practices
- (c) To restore and maintain environmental integrity and services
- (d) To improve opportunities for sustainable livelihoods
- (d) To build technical and administrative capacity for sustainable use and disaster mitigation

**Duration of Services:** 2 years

**National executing agency:** Ministry of Physical Planning, with the collaboration other Selected Agencies and Government Corporations

**Description of activities and tasks:**

- (a) Policy, institutional and organizational arrangements for effective flood plain management
- (b) Technical studies to inform planning and decision making
- (c) Area plans supported by engineered solutions for storm water management and flood control
- (d) Area Specific Land Development Guidelines and Standards (for structures and agriculture)
- (e) Selective restoration of degraded areas (River banks, vegetated slopes, riparian forests)
- (f) Promotion of sustainable farming techniques
- (g) Public awareness and participation

**Expected results and products**

- (a) Communities appreciate and adopt land use and building standards
- (b) Land Use is rationalized in a sustainable manner
- (c) Selected communities stand to benefit from the implementation of area plans for settlements
- (d) Cooperation and collaboration between government entities and between the private and public sectors are strengthened
- (e) Private and public actors have taken necessary measures to reduce vulnerability
- (f) Agencies with monitoring and enforcement responsibilities are performing their duties in an efficient and effective manner

**Total Required Investment (Provisional Estimated):                    US\$2.5 m**

**PROJECT TITLE: MULTI-STAKEHOLDER COLLABORATION IN REDUCING VULNERABILITY IN THE CUL DE SAC WATERSHED**

**Sector: MULTI-SECTORAL**

**BACKGROUND:** There is need for an organized multi-stakeholder response to future threats from natural hazards to Bexon and other settlements in the Cul de Sac watershed. Lessons from the Ravine Poison hazard that killed many in the 1930s and from Tomas are that unsustainable land use practices in the upper parts of the watershed and building practices in the Cul de Sac river flood plain can lead to damages and loss (property, livelihoods and life) of significant proportions. Efforts to reduce vulnerability of settlements within it must address the water shed as a unit because of its physical character and hydrological influences.

**Project objectives**

- (a) To improve land use and building practices by removing barriers to the adoption of best practices
- (b) To reduce future risks to settlements through area planning that is informed engineering solutions and mitigation strategies and practices
- (c) To restore and maintain environmental integrity and services
- (d) To improve opportunities for sustainable livelihoods
- (e) To build technical and administrative capacity for sustainable use and disaster mitigation

**Duration of Services:** 2 years

**National executing agency:** Ministry of Physical Planning, with the collaboration other Selected Agencies and Government Corporations

**Description of activities and tasks:**

- (a) Policy, institutional and organizational arrangements for effective flood plain management
- (b) Technical studies to inform planning and decision making
- (c) Area plans supported by engineered solutions for storm water management and flood control
- (d) Area Specific Land Development Guidelines and Standards (for structures and agriculture)
- (e) Selective restoration of degraded areas (River banks, vegetated slopes, riparian forests)
- (f) Promotion of sustainable farming techniques
- (g) Public awareness and participation

- (h) Waste management (monitoring, measurement and best practices)

**Expected results and products**

- (a) Communities appreciate and adopt land use and building standards
- (b) Land Use is rationalized in a sustainable manner
- (c) Selected communities stand to benefit from the implementation of area plans for settlements
- (d) Cooperation and collaboration between government entities and between the private and public sectors are strengthened
- (e) Private and public actors have taken necessary measures to reduce vulnerability
- (f) Agencies with monitoring and enforcement responsibilities are performing their duties in an efficient and effective manner

**Total Required Investment (Provisional Estimated):                      US\$2.5 m**

**PROJECT TITLE: BUILDING CAPACITY FOR EFFECTIVE LANDUSE PLANNING AND ENFORCEMENT OF LAND DEVELOPMENT AND BUILDING STANDARDS IN REDUCING VULNERABILITY TO HAZARDS**

**Sector: GOVERNMENT/PLANNING AND REGULATION**

**BACKGROUND:** Damages suffered during Tomas, are partly the result of unsustainable land use and failures to enforce land development guidelines and codes for building. Immediate steps should be taken to improve technical, administrative capacity and operational procedures within the Physical Planning Section (PPS) and Development Control Authority (DCA) office, to effectively enforce land development and building standards in the medium and short term.

**Project Objectives**

(a) To undertake needs/gaps evaluation of technical, administrative and operational procedures within the joint PPS/DCA office

(b) To determine requirements for staffing, organizational restructuring, changes to operational and data management procedures, gained from the gaps/needs identified

(c) To use the identified requirements in devising a plan for infrastructure (equipment, software) required to build capacity in the application of current technologies for physical planning, monitoring and enforcement of development activities

(d) To complete ongoing initiatives in the review and upgrade of relevant codes/standards, laws, regulations and procedures to have them approved or amended and to determine the type and level of staff training required to meet these requirements

(e) To provide in-house technical support, leading to gains in technological transfers and the adoption of state-of-the-art tools and procedures for planning and enforcement beneficial to the PPS and DCA

(f) To increase public awareness and appreciation for planning and enforcement, particularly for benefits derived in building the national resilience to natural hazards

**Duration of Services:** 3 years

**National executing agency:** Ministry of Physical Planning

**Description of activities and tasks:**

(a) Gaps/needs analysis applied using broad-based consultations with staff of the PPS/DCA, collaborating government agencies, private sector interests, and observations of land development and building practices in the field

(b) Preparation of a Staffing and Organizational Restructuring Plan for review and endorsement by the PPS and DCA and approval by Government; organizational changes should consider the need for a specialized Monitoring and Enforcement Unit and a Communications/Public Relations Unit envisioned by the PPS

(c) Determination of educational entry level requirements for key technical and administrative staff; design and execution of in-house training modules for skill development using work tasks to complement formal education

(d) Organization and delivery of 3 training workshops (1 per year) targeted to staff of collaborating agencies with regulatory or review/permitting functions associated with approval of development applications

(e) Design and implementation of a communications /public relations plan for public awareness and appreciation of the functions of the PPS and DCA and for public compliance with land use and building standards, and adherence to legal requirements for the submission and approval of development applications

(f) Publish, after they have been approved or amended, revised versions of the St. Lucia Building Code, the Physical Planning Act, draft regulations, along with environmental impact assessment (EIA) and hazard risk assessment procedures, for public access and use

### **Expected results and products**

(a) The PPS/DCA office is adequately staffed with adequately trained staff

(b) Organizational restructuring is agreed and operational procedures for applications processing, filing and easy retrieval, information management for quick and responsive decision making are in place

(c) Infrastructural requirements have been met for equipment and software that are current with technologies required for physical/landuse planning, and for monitoring and enforcement of land use and building standards

(d) The St. Lucian Public is much more aware and appreciative of the benefits to be derived from improved in building practices that builds resilience to natural and manmade hazards

**Total Required Investment (provisional estimate):                      US\$2.0 m**

## **PROJECT RECOMMENDATIONS**

### **VULNERABILITY REDUCTION**

#### **A. HAZARD AND VULNERABILITY MAPPING – MAIN RIVER BASINS**

Hurricane Tomas demonstrated clearly the effects of an extreme rainfall event on the flood plain areas of St Lucia. In many instances, the banks of the river were overflowed and several communities were either flooded out or cut off for short periods of time. In order to reduce the vulnerability of these communities, the following actions are recommended:

- Carry out a hydrological analysis of the catchments of the major river basins in St Lucia
- Compute the overland areas for flow corresponding to the 1 in 25, 50 and 100 year return period events
- Map, within a GIS platform, the plan form area of flooding corresponding to each of these flood events
- For communities that are within, or adjacent to the areas of flooding, map all infrastructure, including, but not limited to: houses; schools; emergency services (Fire Stations, Police Stations, etc.); petrol stations; shelters; churches
- Based on the combination of hazard and vulnerable areas, develop a risk profile for these communities and as well, prepare workable mitigation strategies for implementation.

#### **B. COSTS**

The anticipated project costs for the project as described above are as follows:

- For the hazard and vulnerability mapping within the main river basins, it is recommended that EC\$2,500,000 be allocated.



**PROJECT TITLE: FORESTS RESTORATION AND REHABILITATION****Sector: FORESTRY**

**Background:** The mass movement of soils that occurred during and after hurricane passage caused the loss 66.2 km of forest roads and trails and 605 hectares of natural forest (320 ha.), plantation forest (137 ha.) and private forests (148 ha.), while unstabilized soils provide a threat to the near shore marine environment, particularly the coral reefs of the SMMA and CAMMA.

**Project Objective:**

This activity is aimed at taking actions that will lead to restoring, stabilizing and rehabilitating the forest reserve areas, including private forests lands and important woodland areas Island-wide. This activity is meant to be conducted within the immediate short to medium term period, lasting between six to 48 months.

**Description of Activities and Tasks**

- To restore the government forest reserve lands through a series of actions, these include:
  - Reforestation of areas where gaps have been created within the forests;
  - Stabilization of landslide areas through direct seeding, planting of natural wildlings, bio-engineering techniques;
  - Clearing of large openings by removing debris and, creating the conducive environment to allow for natural regeneration of natural tree species;
  - Planting of suitable fruit trees to provide food sources for the wildlife species, in particularly the avifauna.
- Reforestation of natural forest areas which have suffered from major landslides and slippage, including forest edges that have been destroyed. Approximately, 365 acres of lands will be reforested.
- Reforestation of plantation forests, after salvaging all possible timber with economic value.
- Reforestation of private forests, buffer stripes, forest corridors and all forest edges.
- Reforestation of all important woodland areas, particularly those lands that are important for wildlife protection and management.
- Stabilization of all critically important private lands both forested and non-forested that are adjacent to the government forest reserves.
- Rehabilitation of trails and other ecotourism facilities
- Restoration of riparian vegetation along major rivers island wide
- Restoration of Forest reserves boundary lines

**Estimated Cost \$2.9 million**

**PROJECT TITLE: ASSESSMENT AND MONITORING OF THE NEAR SHORE MARINE ENVIRONMENT**

**Sector: MULTI-SECTOR**

**Background:** The mass movements of soils has caused the deposit of large amounts of sediments (up to 2.5 inches) on coral reefs and sea grass beds of the near shore marine environment. This sedimentation is still continuing since the landslides have not been stabilized as yet and large sediment plumes can be observed after each shower. Increased sedimentation will affect the health of the corals and sea grass beds and this will have a negative impact on fisheries and dive tourism.

**Goals:**

To provide a scientific baseline for actions aimed at restoration of reefs and sea grass beds and ultimately to ensure the sustainable use of these biodiversity resources by fishing communities and eco-tourism.  
Indicative budget: US \$ 0.350 million

**Project duration: 24 months**

**Activities:**

Monitoring levels of sediment and debris  
Monitor health of sea grass beds and coral reefs  
Mapping of affected areas  
Evaluate and propose possible actions  
Adjust existing management plans for SMMA and CAMMA

**PROJECT TITLE: NATION-WIDE RAINWATER HARVESTING PROGRAMME**

**Background:** In 2010, Saint Lucia has experienced weather extremes at both ends of the spectrum: extreme drought, the worst in forty years, and extreme rainfall in the form of Hurricane Tomas. In both cases, potable water supply was either severely reduced, or disrupted, leaving many communities and individual households and businesses without water for extended periods.

In the case of Tomas, the potable supply, which depends on river sources, was severely impacted by sedimentation, damage to infrastructure, much of which took weeks to address. Therefore, even in the presence of abundant precipitation, many were without municipal water and those hardest were those without water tanks to capture and store rainwater for domestic use. Succeeding in popularizing rainwater harvesting would therefore reduce the level of dependence on WASCO reduced water and build resilience at the community and household level in the face of extreme weather events. In the past, rainwater harvesting was quite widespread but declined with the increased availability of piped potable water. Recent work in the Mabouya Valley and under the SPACC Project (Coconut Bay Beach Resort and Spa) demonstrate the feasibility and desirability of RWH at varying scales, especially in the context of existing everyday water constraints and the projected decrease in water availability arising from climate change and the reduced capacity of the John Compton Dam to provide for current needs due to increasing sedimentation levels.

The installations anticipated would reduce significantly the dependence on the surface water supplies and will be used to augment the national collection and storage capacity for distribution. Independent units will also be installed for specific locations where applicable.

**Goal:** To build national/societal resilience to extreme weather events through increased rainwater harvesting.

**Objective:** To realize the wide adoption of effective and safe rainwater harvesting at the community, institutional and household level

**Budget: US \$ 5.75 M**

**Actions (Possible)**

1. Conduct baseline assessment of RWH in Saint Lucia
2. Review, strengthen and implement legislative, framework to guide RWH.
3. Institute fiscal (tax, import concessions) regime to promote adoption of RWH practices by households and the private sector;
4. Install collection and storage systems in specific communities for local and national distribution; applying lessons learnt from Integrated Watersheds and Coastal Areas Management (IWCAM) project.
5. Undertake extensive public awareness and education programme.

**PROJECT TITLE: IMPROVING AWARENESS FOR HAZARD RISK REDUCTION**

**Background:** The experiences from the series of natural events within the last three decades have not served to entrench in our minds and manifested in our behaviour, the lessons that should have been learnt. Public awareness and information programmes, as currently implemented, are considered grossly inadequate for securing cross-generational behavioural change.

**Project Description**

Noting that improving awareness should be predicated on an understanding of the current level of knowledge, attitudes and practices (KAP) related to hazard risk reduction, a KAP should be carried out to serve as the basis for a communications plan for improving public awareness and to change behaviours that contribute to increased risks in communities, particularly in hazard prone areas. The plan must be continuous in its design and implementation to cater to cross-generational changes within communities and in the wider society. In support of this communications plan, stakeholder awareness and education will focus on the interactions between people and the environment, drawing a cause and effect relationship between the two as it relates to exacerbating the impacts of natural events. In keeping with this and based on the results of the KAP study, the project will develop and implement the education and public awareness strategy which will be supported by a media campaign targeting all publics, including senior decision makers and members of the “political directorate.”

This project will give particular consideration to reducing the impacts of activities in high risk areas relating to the use of the environment by poorer communities where livelihoods are threatened. Special treatment will be given to those communities in relatively high risk areas where relocation to safer areas is not immediately feasible focusing on reducing risk from upland activities.

**Goal:** To increase community resilience to natural and anthropogenic hazards in Saint Lucia

**Objective:** To reduce vulnerability in hazard prone areas through raising awareness and influencing behavioural change in communities

**Indicative budget:** US\$ 0.470 million

**Duration of project intervention:** 18 months

**Key activities** may include:

1. Knowledge, attitude and practice (KAP) study on hazard risk reduction issues (USD 70K)
2. Communications plan for improving public awareness and environmental education developed and implemented. (USD 20K)
3. Development of an “impact educational campaign” to be incorporated into the national education system. (USD 20K)
4. Development and dissemination of educational material for various publics including decision/policy makers. (USD140K)
5. Provide tips on flood and landslide mitigation, abatement and risk reduction; public announcements through the media; and, messaging through the entertainment sector. (USD 100K)
6. Development and dissemination of other appropriate media products as informed by the KAP study. (USD120K)

**PROJECT TITLE: INTEGRATED SLOPE MANAGEMENT IN VULNERABLE AREAS**

**Background:** The major watersheds of St. Lucia are considered excellent case studies and sites for implementing “state of the Art” considerations and mechanism to sustain proper land management and socio-economic development. Generally they consist of Government Forest Reserves, mixed agriculture, and private forests in the upper areas, and settlements, intensive agriculture and livestock production in the middle and lower areas. While this arrangement of land use in theory may seem acceptable, in practice their impacts on people and the natural environment has been nothing but catastrophic for a multitude of reasons.

The existence of privately owned lands in what is largely a hilly and unstable topography, coupled with inadequate or unsustainable management frameworks/practices, has led to many severe forms of unsustainable land management practices which contribute significantly to degradation including environmental degradation. Some of these practices include unregulated changes in land use, inappropriate land cover, poor land and soil management practices, poor waste management, and the use of the waterways as disposal points for agricultural and other waste.

A harmonious relationship between communities and the land from which livelihoods are derived is essential. Unsound land use practices on slopes increase the threat to these livelihoods necessitating improved slope stabilization interventions.

**Goal:** To reduce risk posed to communities as a consequence of unsound land use on slopes

**Objectives:**

1. To develop slope stabilisation capabilities, involving the use of traditional and other technologies on steep and unstable slopes.
2. To increase the effectiveness of cropping systems that is consistent with improved slope stabilization without compromising livelihood potential.

**Activities**

1. Mapping of existing landslides.
2. Conduct geophysical and bio-engineering investigations
3. Implement land stabilization treatments, including but not limited to cropping systems, riverbank stabilization and surface runoff management.

**Project Duration:** 5 years

**Project Cost:** US \$15 million





ECONOMIC COMMISSION FOR LATIN AMERICA AND THE CARIBBEAN  
Subregional Headquarters for the Caribbean  
#1 Chancery Lane, P.O. Box 1113, Port of Spain, Trinidad and Tobago