



Government of Saint
Lucia



Ministry of Infrastructure, Port
Services and Transport

Hurricane Tomas Emergency Recovery
Project



Hydraulic assessment for flood risk assessment in Soufrière, Fond St Jacques and Dennery

Report # 1: Site characterization, Flood Hazard and Vulnerability Analysis

Version 2



December 2013

Partner:



Quality

Project title	Hydraulic assessment for flood risk assessment in Soufrière, Fond St Jacques and Dennery
Report title	Report # 1: Site characterization, Flood Hazard and Vulnerability Analysis
Date	December 2013
Author(s)	J. Marmagne / V. Fabrègue
N°	RIV 22852E

Quality control

Version	Date	written by	Visa:
1	07/26/13	J. Marmagne	V. Fabregue
2	15/12/13	J. Marmagne/ V. Fabregue	M. Raymond

Recipients

Sent to:		
Name	Organism	sent :
Myrtle Drysdale Octave	Ministry of Infrastructure, Port Service and Transportation	08/02/13
Myrtle Drysdale Octave	Ministry of Infrastructure, Port Service and Transportation	20/12/13

copy:		
Name	Organism	sent :

Table of Contents

Chapter 1. Introduction	8
Chapter 2. Schedule of field Investigation and meetings conducted in Saint Lucia	10
Chapter 3. Meetings.....	13
3.1 Kick-off meeting – 07/03/13.....	13
3.2 Interview with Elizabeth Charles-Soomer – 07/03/13 and 07/10/13 ..	13
3.3 Interview with Jude Regis – 07/04/13	14
3.4 Interview with Lurna Raoul – 07/04/13 and 07/11/13	14
3.5 Interview with Venantius Descartes – 07/04/13	15
3.6 Interview with Ovid Martyr – 07/11/13	16
3.7 Interview with Ausbert Regis – 07/11/13	16
3.8 Interview with A.L. Dawn French – 07/11/13	17
3.9 Interview with Benedict James and Mary Felicien – 07/11/13.....	20
3.10 Interview with Farzana Yussif-Leon – 07/12/13	20
3.11 Interview with Augustin Poyotte – 07/12/13	22
3.12 Conclusion	23
Chapter 4. Data collected	24
Chapter 5. Topographical data analysis	26
5.1 Data available	26
5.2 Data to recover (Royal Survey Services)	27
Chapter 6. Field investigations	29
6.1 Dennery.....	29
6.1.1 General comprehension	29
6.1.2 Ravine Trou à l'Eau.....	33
6.1.3 Central drain.....	42
6.1.4 Dennery River (Mole River).....	48
6.1.5 Comments	52

6.2 Fond Saint Jacques	53
6.2.1 General comprehension	53
6.2.2 Field investigations.....	56
6.2.3 Comments	62
6.3 Soufriere	63
6.3.1 General comprehension	63
6.3.2 Field investigations.....	65
Chapter 7. Issues and vulnerability first analysis	76
7.1 Methodology	76
7.2 Maps.....	76

List of Figures

Figure 1 : Localisation Map : Dennerly, Fond Saint Jacques and Soufrière	9
Figure 2 : Organisational structure of the NEMO	18
Figure 3 : Existing hydrological Monitoring network.....	21
Figure 4 : Example of photogrammetry data available (here Soufriere).....	26
Figure 5 : Land survey in Dennerly.....	27
Figure 6 : Land survey in Soufriere.....	27
Figure 7 : Land survey in Fond Saint Jacques.....	28
Figure 8 : <i>Dennerly flood plain, urbanized hills and mouth of the Mole River</i>	29
Figure 9 : <i>Dennerly drainage system</i>	30
Figure 10 : Photography of Dennerly Primary School during Tomas (cimetary in background)	32
Figure 11 : Silt Deposit after Tomas in Mole Road	32
Figure 12 : Field Investigation in Dennerly : Ravine Trou à l'Eau – Photograph index	34
Figure 13 : Field Investigation in Dennerly : Ravine Trou à l'Eau – Plate # 1	35
Figure 14 : Field Investigation in Dennerly : Ravine Trou à l'Eau – Plate # 2	36
Figure 15 : Field Investigation in Dennerly : Ravine Trou à l'Eau – Plate # 3	37
Figure 16 : Field Investigation in Dennerly : Ravine Trou à l'Eau – Plate # 4	38
Figure 17 : Field Investigation in Dennerly : Ravine Trou à l'Eau – Plate # 5	39
Figure 18 : Field Investigation in Dennerly : Ravine Trou à l'Eau – Plate # 6	40
Figure 19 : Field Investigation in Dennerly : Ravine Trou à l'Eau – Plate # 7	41
Figure 20 : Field Investigation in Dennerly : Central Drain – Photograph index	43
Figure 21 : Field Investigation in Dennerly : Central drain – Plate # 1	44
Figure 22 : Field Investigation in Dennerly : Central drain – Plate # 2	45
Figure 23 : Field Investigation in Dennerly : Central drain – Plate # 3	46
Figure 24 : Field Investigation in Dennerly : Central drain – Plate # 4	47
Figure 25 : Field Investigation in Dennerly : Ravine Dennerly – Photograph index.....	49
Figure 26 : Field Investigation in Dennerly : Ravine Dennerly – Plate # 1	50
Figure 27 : Field Investigation in Dennerly : Ravine Dennerly – Plate # 2.....	51
Figure 28 : photography of Fond Saint Jacques upstream bridge (road to Migny)	53
Figure 29 : photographs of Fond Saint Jacques downstream bridge (Mochas' bridge) just after Tomas and after cleaning.....	54
Figure 30 : photographs of Fond Saint Jacques damages just after Tomas.....	55
Figure 31 : photographs of actuel Mocha's bridge rebuilt	56
Figure 32 : Field Investigation in Fond Saint Jacques : Photograph index	57
Figure 33 : Field Investigation in Fond Saint Jacques : Plate # 1	58
Figure 34 : Field Investigation in Fond Saint Jacques : Plate # 2	59
Figure 35 : Field Investigation in Fond Saint Jacques : Plate # 3	60
Figure 36 : Field Investigation in Fond Saint Jacques : Plate # 4	61
Figure 37 : Soufriere River beside the hospital during Tomas	64
Figure 38 : Silt deposited in the town by Tomas	64
Figure 39 : Field Investigation in Soufriere : Photograph index	66

Figure 40 : Field Investigation in Soufriere : Plate # 1	67
Figure 41 : Field Investigation in Soufriere : Plate # 2	68
Figure 42 : Field Investigation in Soufriere : Plate # 3	69
Figure 43 : Field Investigation in Soufriere : Plate # 4	70
Figure 44 : Field Investigation in Soufriere : Plate # 5	71
Figure 45 : Field Investigation in Soufriere : Plate # 6	72
Figure 46 : Field Investigation in Soufriere : Plate # 7	73
Figure 47 : Field Investigation in Soufriere : Plate # 8	74
Figure 48 : Field Investigation in Soufriere : Plate # 9	75
Figure 49 : Issues in Dennery.....	77
Figure 50 : Issues in Fond Saint Jacques.....	78
Figure 51 : Issues in Soufriere	79
Figure 52 : Dennery floodplain (field investigation).....	80
Figure 53 : Fond Saint Jacques floodplain (field investigation).....	81
Figure 54 : Soufriere floodplain (field investigation).....	82

List of Tables

Table 1 : Meetings and investigations during Saint Lucia's first Mission.....	10
Table 2 : Responsibilities Matrix for Emergency/ recovery functions in the case of tropical Storm.....	19
Table 3 : collecting data during Saint Lucia's first Mission.....	24

Acronyms and abbreviations

GOSL	Government Of Saint Lucia
PCU - MF	Project Coordination Unit – Ministry of Finance
MIPS&T	Ministry of Infrastructure, Port Services and Transportation
NRDU	National Reconstruction and Development Unit

Chapter 1. Introduction

The vulnerability of Saint Lucia's population and economy, to natural disasters related to water phenomena has become an important national issue.

In October 2010, the Hurricane Tomas impacted Saint Lucia. An important rainfall, in quantity (533 mm) and duration (24 hours), accompanied this hurricane. Due to Saint Lucia's topography and land occupation, numerous flooding and landslide were deployed. To support the Saint Lucia's recovery and reconstruction effort the government of the island received a Credit from the World Bank.

The extreme rainfall associated to the Hurricane Tomas also altered the river-courses and accumulated sediment in the channels due to significant number of landslides and important run-off. These sediments now increase the flooding risk, in particular on specific risk areas: the watershed communities of Dennery, Soufriere and Fond St-Jacques.

The objectives of the assignments are to provide the implementation of flood management measures in 3 watershed areas (of the Dennery, Soufriere and Fond St-Jacques communities):

- Carry out flood risk assessment
- Identify and quantify appropriate cost effective remedial measures to reduce flood hazard.

The project is divided in 6 phases:

- Phase 1 : Site characterization, flood hazard and vulnerability analysis
- Phase 2 : Drainage designs standards and flood risk mapping
- Phase 3 : River and drainage and mitigation measures
- Phase 4 : Preliminary designs
- Phase 5 : flood mitigation measures
- Phase 6 : Flood risk design and flood management training

This report describes the phase 1 analysis. It contains:

- The characteristics of the sites identified in this assessment,
- The conditions of the site pre and post Tomas,
- The methodology for undertaking the site characterization,
- The intended approach for conducting the vulnerability analysis.

Figure 1 : Localisation Map : Dennery, Fond Saint Jacques and Soufrière



Chapter 2. Schedule of field Investigation and meetings conducted in Saint Lucia

The table below indicates the schedule of all meetings and site investigations conducted by Egis with various stakeholders during the first stay in Saint Lucia (3rd to 12th of July 2013).

Table 1 : Meetings and investigations during Saint Lucia's first Mission

Date	Meeting / task	Resources	Interest
07/03/13, pm	Kick-off meeting	<ul style="list-style-type: none"> Myrtle Drysdale Octave – Procurement Officer – Project Coordination Unit – Ministry of Finance Laurna Raoul – Civil Engineer – Ministry of infrastructure, Port Services and Transportation • ... • ... 	<ul style="list-style-type: none"> Beginning of mission Presentations Contract Project review
07/03/13, pm	Interview with Elizabeth Charles- Soomer	<ul style="list-style-type: none"> Elizabeth Charles- Soomer- Unit Chief - National Reconstruction and Development Unit 	Tomas hurricane explanations. Data available from NRDU.
07/04/13	Interview with Jude Regis	<ul style="list-style-type: none"> Jude Regis – Project Coordinator – Hurricane Tomas Recovery Project 	Investigations undergoing on the cul-de-sac area.
07/04/13 am	Interview with Laurna Raoul	<ul style="list-style-type: none"> Laurna Raoul – Civil Engineer – MIPS&T 	Tomas hurricane explanations. Data available from MIPS&T.
07/04/13 am	Interview with Venantius Descartes	<ul style="list-style-type: none"> Venantius Descartes - Meteorological Service 	Rainfall data and hydrology. Available data for Tomas.
07/04/13 am	Water Resources Management Agency		Recovering form to ask for hydrological data.
07/04/13 pm	Overview of the three areas: Dennery, Fond		In preparation to the field investigations.

Date	Meeting / task	Resources	Interest
	Saint Jacques and Soufriere.		
07/05/13 all day	Dennery field investigations	<ul style="list-style-type: none"> • Citizens • Nicholas Cutbert (718-48-43) 	Field investigations Understanding of the floods phenomena: 2 majors floods in October: 6 th (local heavy rainfall) and hurricane Tomas the 31 st .
07/06/13 all day	Fond Saint Jacques investigation	<ul style="list-style-type: none"> • Citizens • Farmer in Migny (715-85-42) • 	Field investigation, notes compilation and understanding of the debris flow phenomenon during Tomas.
07/07/13	Day-off		
07/08/13	Soufrière investigation	<ul style="list-style-type: none"> • Citizens • Guide : Kent Alfred • Damaged house owner: Sylvestre Gaston 	Field investigation and notes compilation. Understanding of the flood phenomenon during Tomas.
07/09/13	Chantal Storm Work in Hotel		Topography analysis. Data analysis. Organization.
07/10/13 am	Interview with Elizabeth Charles- Soomer	<ul style="list-style-type: none"> • Elizabeth Charles- Soomer- Unit Chief – NRDU 	Contacts for GIS data.
07/10/13 am	Interview with David Alphonse	<ul style="list-style-type: none"> • David Alphonse – Senior cartographer – Survey and Mapping Section 	Collecting GIS Data.
07/10/13 am	Interview with Myrtle Drysdale Octave	<ul style="list-style-type: none"> • Myrtle Drysdale Octave – Procurement Officer – PCU - MF 	Half-mission meeting. Organization
07/10/13 pm	Meeting in Dennry with RSS company	<ul style="list-style-type: none"> • John G. Cenac – Managing director – Licensed Surveyor – Royal Survey Services Ltd 	Planning Topographical survey to be done.
07/11/13 am	Meeting with Laurna Raoul	<ul style="list-style-type: none"> • Laurna Raoul – Civil Engineer – MIPS&T 	After field investigation meeting. Dialog on works in progress or done. Studies to be collected.

Date	Meeting / task	Resources	Interest
			Collecting topographical data (photogrammetry).
07/11/13 am	Meeting with Ministry of Physical Mapping	Ovid Martyr – Ministry of Physical Mapping	Has to validate the design for flood mitigations.
07/11/13 pm	Interview with Ausbert Regis as part from the Dennerly Disaster Community	<ul style="list-style-type: none"> Ausbert Regis – Special Security Advisor 	Testimony on Tomas events in Dennerly.
07/11/13 pm	Interview with Mrs A. L. Dawn French – NEMO	<ul style="list-style-type: none"> A.L. Dawn French – Director of National Emergency Management Organisation 	<p>Understanding crisis mechanism before – during and after - flooding.</p> <p>Understanding flood alert management on Corinthe river.</p>
07/11/13 pm	Meeting at Dennerly Primary School	<ul style="list-style-type: none"> Benedict James – Principal – Dennerly Primary School Mary Felicien – Principal – Dennerly Infant School 	Testimonies on Tomas event.
07/12/13 am	Interview with Farzana Yusuf-Leon – Water Resources Management Agency	<ul style="list-style-type: none"> Farzana Yusuf-Leon – Director and Water resources specialist - Water Resources Management Agency 	<p>Understanding water resources management in Saint Lucia.</p> <p>Rainfall and gauging data.</p>
07/12/13 am	Interview with Augustin Poyotte	<ul style="list-style-type: none"> Augustin Poyotte – Chief Architect – Ministry of Physical Development, The Environment, Housing, Urban Renewal and Local Government 	<p>Understanding activities from this ministry.</p> <p>Testimonies for Tomas event.</p>

All the information collected during this first stay, site comprehension, collected and missing data are detailed later in this report.

Chapter 3. Meetings

3.1 Kick-off meeting – 07/03/13

The first meeting of EGIS in Saint Lucia was the Kick-off meeting with :

- for Saint Lucia Government: Myrtle Drysdale Octave as procurement officer in PCU – MF, Larna Raoul as a civil engineer in MIPS&T, Mrs From and Mr from.....,
- and for EGIS: Valerie Fabregue and Julien Marmagne, senior hydrological and hydraulic engineers.

This meeting permitted to present the comity in charge of this assessment and the team composition of Egis.

The review of the technical requirement and the technical corresponding offer were done during this meeting.

The importance of stakeholder's consultation during the study has been highlighted. It's also mentioned in the addendum #001 joined to the contract.

Egis mentioned the data that needed to be collected during the stay in Saint Lucia (studies written in the contracts and topography).

The different stakeholders needed time to collect those data, consequently, others meeting had been planned for the next days, as described below.

3.2 Interview with Elizabeth Charles-Soomer – 07/03/13 and 07/10/13

Elizabeth Charles-Soomer is the Programm Manager of the NRDU and is involved in post-Tomas works that have been done to recover transportation and housing in the affected areas.

Concerning Dennery's area, we understand that they were two meteorological events that caused flooding:

- First one at the beginning of October
- Second one at the end of October (Tomas hurricane: 10/30/10).

The flooding is correlated with a high level of water in town and in cemetery.

Concerning Fond Saint Jacques' area, the flooding problems were different and increase by many landslides that occurred in the upstream part of the catchment. Those landslides occurred in areas where there was no human land use but only humid forest typical from tropical Island: luxurious vegetation with big trees and steep slopes. The debris flows were spectaculars.

In numerous sites, the landslides affected the River trajectory.

Located downstream from Fond Saint Jacques, Soufriere was also damaged by debris flow and flooding.

After Tomas, Ministry of Physical Development established a diagnosis on every house or building that had been damaged by Tomas to decide if it is still efficient to maintain its use.

Mrs Soomer explained the difficulties for the government to make land acquisitions where there is an environmental risk (in particular Flood risk and landslide risk) or where a diagnosis of non-acceptable risk in the affected structure is delivered.

Mrs Soomer advised us to contact and see Mr David Alphonse to collect GIS data.

3.3 Interview with Jude Regis – 07/04/13

Jude Regis is responsible from the hydraulic assessment in the Cul De Sac River watershed.

A Canadian consultant is working on this study: Stanley Consultant.

They have done a Hydraulic model in the Cul De Sac River for Tomas event. This is the first step of the study and their first report will be sent to Saint Lucia Government in July-August.

As it is the same phenomenon that EGIS is studying for this assessment, but in a different location, it could be helpful to exchange the reports and data (at least hydrological data) between the two consultants in order to insure more consistency between the studies.

3.4 Interview with Lurna Raoul – 07/04/13 and 07/11/13

The description of Tomas Hurricane was similar to Mrs Soomer's explanation.

Mrs Raoul introduced us to the Meteorological Service (see next paragraph) and to the Water Resources Management Agency (where unfortunately we couldn't have an interview for that day).

A second meeting with Mrs Raoul were done after Soufriere, Fond Saint Jacques and Dennery field investigations.

New bridges, footbridges, hydraulic calibrations have been done after Tomas. We mentioned the following structures for which we are expecting data:

- In Soufriere:

- Downstream bridge (close to the fire station): damaged by Tomas but not destroyed. Expecting data: hydraulic or physical design – topography (Consultant or Ministry?).
- Footbridge between schools and center town: destroyed by Tomas and rebuilt in higher elevation. Expecting data: hydraulic or physical design – topography (Consultant or Ministry?).
- New footbridge upstream from the stadium: the downstream footbridge was destroyed by Tomas. Expecting data: hydraulic or physical design – topography (Consultant or Ministry?).
- Cresslands Bridge: Right Bank tributary of the Soufriere Bourg River (upstream from town) that was destroyed by Tomas. The new bridge is finished; the embankment and – river training works are in progress (07/08/13). Expecting data: hydraulic or physical design – topography (Consultant or Ministry?).
- Fond Saint Jacques:
 - Mocha's bridge: it linked Fond Saint Jacques and Bois d'Inde. Tomas damaged this bridge with important tree debris jam. It is now closed to vehicles and authorized only for pedestrians. A new design has been done and the work will occur soon. Expecting data: hydraulic or physical design (Consultant or Ministry?).
 - Upstream Bridge (road to Migny and Edmund Forest Reserv). During Tomas, the metallic structure was washed away and stopped in a house, 80 meters downstream. The metallic structure was replaced on its abutment after Tomas.
- In Dennery:
 - In the middle part of the town, upstream from main road, a ravine is draining a part of the hill. The ravine outlet is a pond around the main street which is connected downstream with the city rain water network. Before going to the pond, the ravine is having hydraulic calibration works. Expecting data: hydraulic or physical design (Consultant or constituency?).
 - Two dikes were built after Debby hurricane (1994) : one on the left bank from Dennery River (also called Mole River) and one along the beach. Those dikes are protected with riprap. Expecting data: hydraulic or physical design (Consultant or Ministry?).

3.5 Interview with Venantius Descartes – 07/04/13

There are 34 rainfall stations in Saint Lucia for which rainfall data exist.

27 are still working today.

Most of them provide daily data except the two airports stations that provide hourly data.

In this assessment, the following useful stations data were collected:

- For Soufrière and Fond Saint Jacques:
 - Soufriere ;
 - Edmund Forest,

- Barthe Nursery
- Union Val Estate
- Delcer School
- Saltibus
- For Dennery :
 - Mabouya
 - Cardi
 - Barre de l'Isle
 - Millet
 - Patience Estate
 - Mamiku

Unfortunately, only few stations collected data during Tomas: Union, CARDI and Patience + airports station. The others were damaged by the hurricane.

The hydrological analysis will be provided in next report (#2) and will be based on those data.

3.6 Interview with Ovid Martyr – 07/11/13

Ovid Martyr is working in the Ministry of Physical Mapping. This Ministry is in charge of controlling the infrastructures design. Any project of infrastructure has to be validated by them before being done.

The preliminary design that we have to do to reduce flood risk will have to be validated by this Ministry.

3.7 Interview with Ausbert Regis – 07/11/13

Ausbert Regis is involved in Dennery's community. His experience in Dennery was helpful to understand what did happen during Tomas.

He explained that rain water network is about 50 years old in Dennery, and had been calibrated for no hill urbanisation. It is connected to the Mole river with two outlets.

The Mole river dike was built after Debby hurricane in approximately 1995-1996.

The ravine Trou d'Eau is today artificial on its 250 meters ending. It used to be a mangrove before.

Before the hurricane, the 5th of October 2010, a local heavy rain affected Dennery's catchment.

A destroying flood occurred during that meteorological event, but it was a bit less important than during Tomas. Center town was under water (schools and waterfront streets). The sea level was higher in this event than during Tomas.

The government could provide an efficient and quick recovery program to clean houses and rebuilt the city. (It was a very local meteorological event).

When Tomas occurred, several days after, all the drainage system wasn't probably cleared and it may have affected the flooding mechanism.

While Tomas was passing close to Saint Lucia, the water level in the Dennery River (Mole River) was higher than the dikes near the bridge. Water started flooding over the dike and filling the city as a tank. Mole road could be considered as a river at this time. The connection between river and rainwater network may have increased the process. Farmers located upstream from the bridge were flooded, as the plain in town (schools, cemetery, houses and streets).

Urbanization in Dennery has increased during the past decades, especially in Bois Joli Neighbourhood. The consequence is that runoff has increased in those areas, creating higher flows downstream.

The water level in town decreased quite shortly, estimated to about 2 or 3 hours.

The mouth of the Mole river is regularly blocked by natural silting. Sometime a farmer desilts it (when his irrigation pumping system needed more fresh water). During Tomas the mouth was blocked. There is no maintenance program.

Before Tomas the river used to be deeper than it is now between the bridge and the ocean. Childs often jumped from the bridge into the river, which is today unthinkable. This prove that the river hasn't been desilted for a long time.

Recovering a normal situation in Dennery took more time after Tomas than after 5th of October. Reason is that the entire island was affected by Tomas; government materials and human help had to be scattered in all communities.

3.8 Interview with A.L. Dawn French – 07/11/13

A.L. Dawn French, as director from the National Emergency Management Organisation (NEMO), explained us the NEMO objectives and its operating system.

The following illustrations are taken from NEMO website (<http://www.nemo.gov.lc/home/Home.aspx>) and give a synopsis of hurricane emergency plan.

The system is built around efficient representative persons in charge of technical advice, government representatives' decision makers and an organizing committee (NEMAC: National Emergency Management Advisory Committee).

Decisions are then spread to the district committees.

Figure 2 : Organisational structure of the NEMO

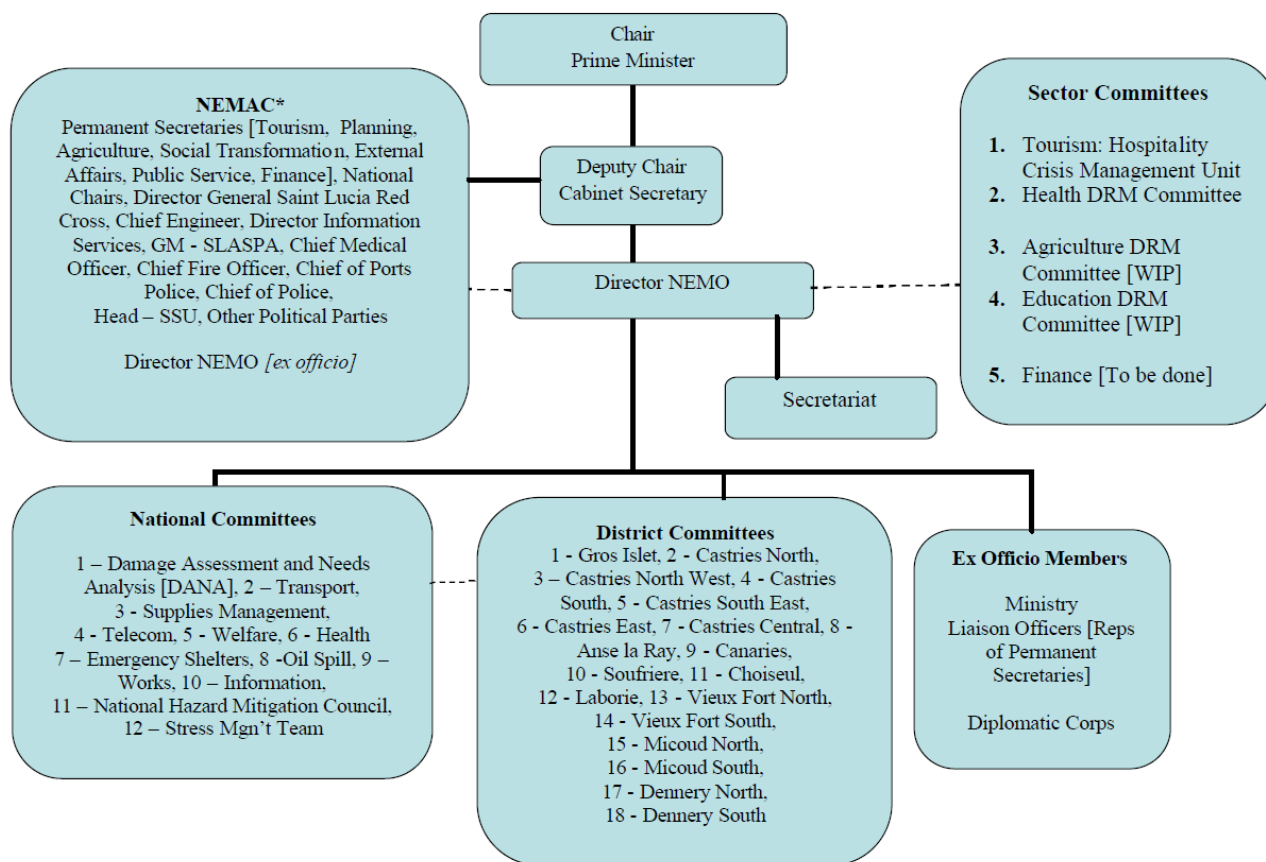

In the situation of hurricane emergency the procedure described in next sheet is applied.

In each step, each responsible organization has to follow a particular procedure consisting for example in uploading meteorological data, communicating report frequently.

NEMO, with the Water Management Agency is testing a new alert system built recently in Corinthe River and based on water level gauge which sends sms messages warn people as soon as there is a quick rise of water level or when a critical level is reached.

This system gives about 15 minutes to the people to shelter in safe places.

This study in Soufriere, Fond Saint Jacques and Dennery will be helpful to improve the flood alert and security management plan in the considered catchments.

Table 2 : Responsibilities Matrix for Emergency/ recovery functions in the case of tropical Storm

Hazard/ Function	Main Responsible Organisation	Key Organisations (secondary)	Support	Sectoral Plans
1.Warning/ Monitoring	Meteorological Office Ministry of Works	Ministry of Agriculture		
2.Notification	NEMO	National Committees, District Committees. Government Ministries.		
3.EOC	NEMO	Disaster Committees, District Committees, Ministries, Private Sector		Sectoral EOCs, MOW, MOH, CMU, Private sector plan
4.Comm- unications	Telecommunications Committee	Private sector. Amateur radio operators.		MOW. Private Sector Plan
5.- Transportation	Transportation Committee	MOW, volunteers. Private sector.		MOW
6.Evacuation	Royal Saint Lucia Police Force	District Committees, Transportation Committee		
7.Shelter management	Shelter Management Committee.	MOE, District Committees, Social Organisations. MOH. Supply management Committee.		
8.Search and Rescue	Fire Service. Police. (land) Police (maritime)	Transportation Committee, MOW.		
9.Security	Police			
10.Medical attention	Health and Welfare Committee	MOH. Private sector. Transportation committee. Fire service, police.		MOH Plan.
11.Environmental	Health and Welfare Committee	MOH. Shelter Management Committee.		MOH
12.Damage & Needs Assessment	Damage Assessment Committee	Ministry of Works		MOH, MOW, Private Sector Plan
13.External Assistance	Ministry of External Affairs	NEMO		
14.Supply Management.	Supply Management Committee	Governmental Ministries. Private sector. Transportation Committee		Private Sector Plan
15.Public Information	Information Committee (GIS)	NEMO, The Media, All Committees.		
16.Protection and Rehabilitation of Infrastructure	Works/Rehabilitation Committee	MOW, Private sector		MOW, Private Sector Plan
17. Environmental Protection and Rehabilitation	Saint Lucia Solid Waste Management Authority	MOW. Transportation Committee.		
18.Reconstruction	Ministry of Planning	NEMO, MOW. All Ministries, Private Sector.		

3.9 Interview with Benedict James and Mary Felicien – 07/11/13

Benedict James and Mary Felicien are the Principals from (respectively) Dennery Primary School and Dennery Infant School. Thus their testimonies about Tomas and after Tomas are important.

The two floods have of course been noticed (5th and 30th of October, 2010) but didn't have exactly the same consequences for each school:

- In Infant School, the water level was higher in the 5th event;
- In Primary school, the water level was higher in the 30th event;
- In the 5th October heavy rain, the Dennery River didn't go over the dike.

A same general description as Ausbert Regis did was confirmed. During Tomas the river goes over the dike and the flood plain reaches the town. The main road was cut by the flood.

The number of students in Dennery is about 1 500, divided as follows:

- Primary school: 375 persons;
- Secondary school: 840 persons;
- Infant school: 300 persons.

The school second floor is used as a shelter, but the Dennery main shelter is the Catholic Church, on the central hill.

The estimated cost of damages in Dennery has been evaluated in a report sent to the World Bank as Saint Lucia asked for a financial help for recovery program.

Concerning the Primary school, the cost of the loss of inside-school material (computer, books ...) is evaluated to about 80 000 \$ EC.

3.10 Interview with Farzana Yussif-Leon – 07/12/13

Farzana Yussif-Leon is Director of the Water Resources Management Agency (WRMA) created in 2009.

This agency has taken water resources ability that was before assumed by Ministry of Agriculture.

The WRMA is in charge of the comprehension of the hydrographical network for water management (resources and flood management). This comprehension goes through field analysis, monitoring network and works proposals.

The WRMA is able to do flow measurements and is collecting data from gauging and automatic stations. The following Figure localizes that network.

Figure 3 : Existing hydrological Monitoring network



Water level gauges with continuing data) had been placed in Mabouya, Degios and Canelle.

Unfortunately there is no gauging station in the studied areas.

To this date, there is no watershed management plan in Saint Lucia.

One Study has been proposed to the World Bank Financial program to provide a general outline of what could be an efficient watershed management plan. Once it will be done, this will have to be applied on one specific watershed to test it and improve it.

3.11 Interview with Augustin Poyotte – 07/12/13

Augustin Poyotte is Chief Architect in Ministry of Physical Development. He contributes in the past Tomas event (rebuilt, housing...).

The testimonies about Tomas effects in Dennery, Fond Saint Jacques and Soufriere were quite similar to the previous testimonies.

Fond Saint Jacques community (estimated to 230 people) was particularly damaged by landslides (38 houses damaged) and the government provided tents for temporary housing.



In Crestland a housing project started before Tomas had to be canceled because of landslides:



3.12 Conclusion

Those numerous consultations were helpful:

- To understand the government organization (who is in charge of what ?),
- To understand what happened during Tomas in the three communities,
- To meet the stakeholders,
- To collect some meteorological and GIS data.

As all the testimonies of the flood phenomena were quite the same, they are judged to be consistent. A lot of people are involved in the post Tomas recovery program.

Tomas was a collective awareness of all the damage that can be done to the people and to the local economy. Since this terrible hurricane, the Saint Lucia's government is improving its organization and efficiency to manage natural event crisis and reduce their effects. This assessment fits perfectly with those goals.

Chapter 4. Data collected

The table below provides all data collected during the first stay in Saint Lucia (3rd to 12th of July 2013):

Table 3 : collecting data during Saint Lucia's first Mission

Name	Type of data	Collecting date	Source
<ul style="list-style-type: none"> disaster locations2010.jpg Ste-Lucia_rapideye_5m_20110103_BWlgrid Soufriere watershed integrated plan_disaster areas 	<ul style="list-style-type: none"> General Map locating disasters areas post Tomas Satellite photography after Tomas Soufriere watershed analysis post Tomas 	07/03/13	Elizabeth Charles-Soomer - NRDU
<ul style="list-style-type: none"> Storm Hazard Assessment for St Lucia Tomas damage Assessment Daily rainfall data (GPS Coordinates, xl file for stations, Localization Map for stations) 	<ul style="list-style-type: none"> Return period analysis in St Lucia's tropical storms for coastal effects Damage inventory and disaster response post Tomas Daily rainfall data pre and post Tomas 	07/04/13	Kinetic Analysis Corporation / Laurna Raoul – MIP&T FDL Consult – Castrie / Laurna Raoul - MIP&T Venantius Descartes / Laurna Raoul – MIP&T / Water Ressources Management Agency
<ul style="list-style-type: none"> Saint Lucia Aerial photographs Topographical data – GIS data (buildings, contours, rivers sections, landslide inventory, ...) 	<ul style="list-style-type: none"> .tif + GIS files 2009 pre Tomas Photogrammetry / Autocad files -2009 pre Tomas ArcGIS files – 2011 post Tomas 	07/10/13	David Alphonse – Ministry of physical development – Survey and Mapping Section
<ul style="list-style-type: none"> Landslide photographs Post Hurricane Tomas Response Committee report 	<ul style="list-style-type: none"> Landslide photographs – after Tomas Post Hurricane Tomas Response Committee report - after Tomas 	07/12/13	Augustin Poyotte – Chief Architect – Ministry of physical development
<ul style="list-style-type: none"> Rainfall data updated (CARDI, Patience, Anse la Raye, Union; Marquis Babonneau) Gauging data Climate Change Report October 2010 	<ul style="list-style-type: none"> Daily Rainfall data updated (CARDI, Patience, Anse la Raye, Union; Marquis Babonneau) Gauging data Climate Change Report October 2010 	<ul style="list-style-type: none"> 07/17/13 07/24/13 	Farzana Yusuf-Leon & Michael Skeete – Water Resources Management Agencie

The collected data allows us to have a better understanding of the flood phenomena during Tomas in the 3 communities.

We have also understood that there are few technical hydrological or hydraulic studies available. We've asked for the design studies of the urgent works that had been done after Tomas but no-one could give some to us (bridges reconstruction studies for example).

There are not a lot of rainfall and no sea elevation data too to perform a precise statistical analysis of the short time rainfalls and sea levels for different return periods, and to estimate the local rainfall and sea level during Tomas.

Indeed, the time between the beginning of the rain and the raise of the rivers levels are very short, less than one day (little catchment areas), so we need local hourly rainfall data to estimate peak flow data in or near the 3 catchments.

Soufriere and Dennery are situated by the Caribbean Sea for the first one and by the Atlantic Ocean for the other. As the flood plains of those sites are very flat, the sea levels must have a large influence during floods: a high sea level can enable the rainfall water to properly and quickly evacuate into the sea, and more, the waves can enter in town causing its own flood.

The photogrammetry data collected are useful to delineate the catchment areas. But they are not enough precise to perform a good hydraulic modelling (water beds are not well delineated for example). But this photogrammetry had been done before Tomas : it will be useful when we get the actual topography to compare the flood plain pre and post Tomas. See next chapter.

Note that the photogrammetry is not available for Fond Saint Jacques area.

Chapter 5. Topographical data analysis

5.1 Data available

The available data are provided by the Survey and Mapping Section of Ministry of Physical Development.

This topography consists in a photogrammetry from 2009 as the following extract shows:

Figure 4 : Example of photogrammetry data available (here Soufriere)



The altitude contours are drawn every 2 foot (0.61m) and the accuracy of this data is not very good and depends from the land use (photogrammetry interpretation).

Moreover, this photogrammetry is based on aerial photographs performed in 2009, that is to say before Tomas. The flood and after the recovery urgent works, may have changed significantly various zones.

Local hydraulic structures design plans are not available too (bridges, dikes, walls, rip-rap ...)

Thus, it is not efficient to permit to have a good knowledge from the riverbed, riverbank and floodplain and to perform an accurate hydraulic modeling.

5.2 Data to recover (Royal Survey Services)

To complete available data in order to permit a good hydraulic modelling, we've asked the company Royal Survey Services (RSS) from Vieux-Fort to do the following survey:

Figure 5 : Land survey in Dennery



Figure 6 : Land survey in Soufriere

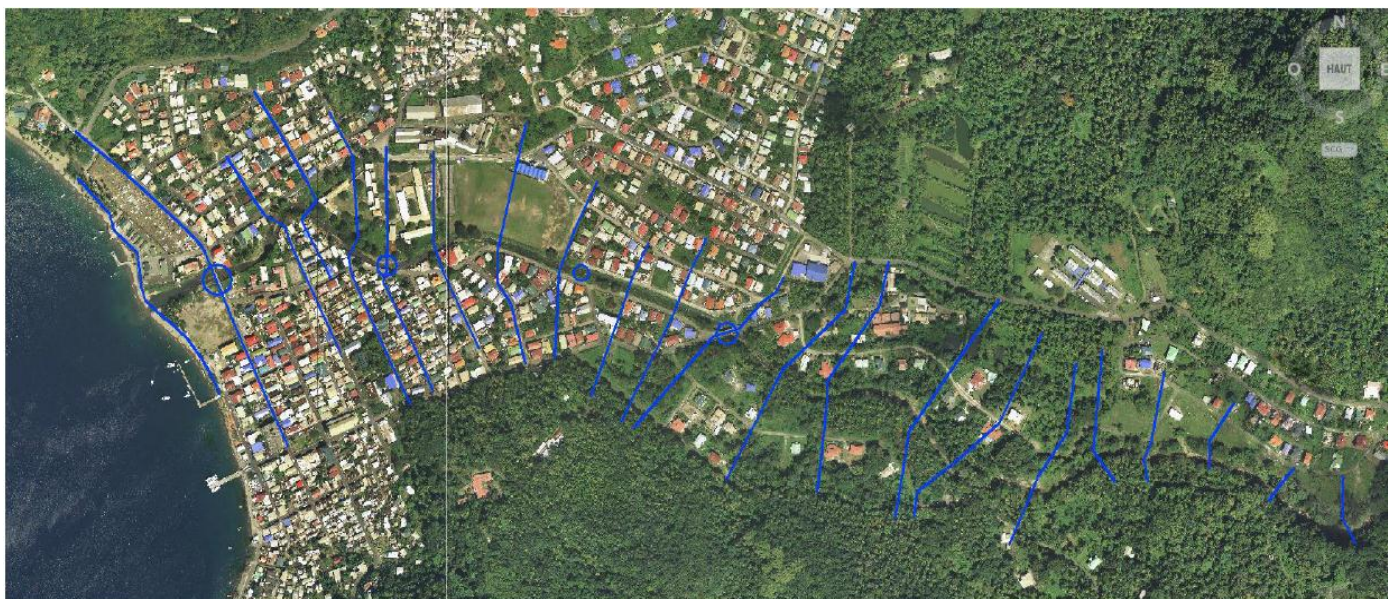
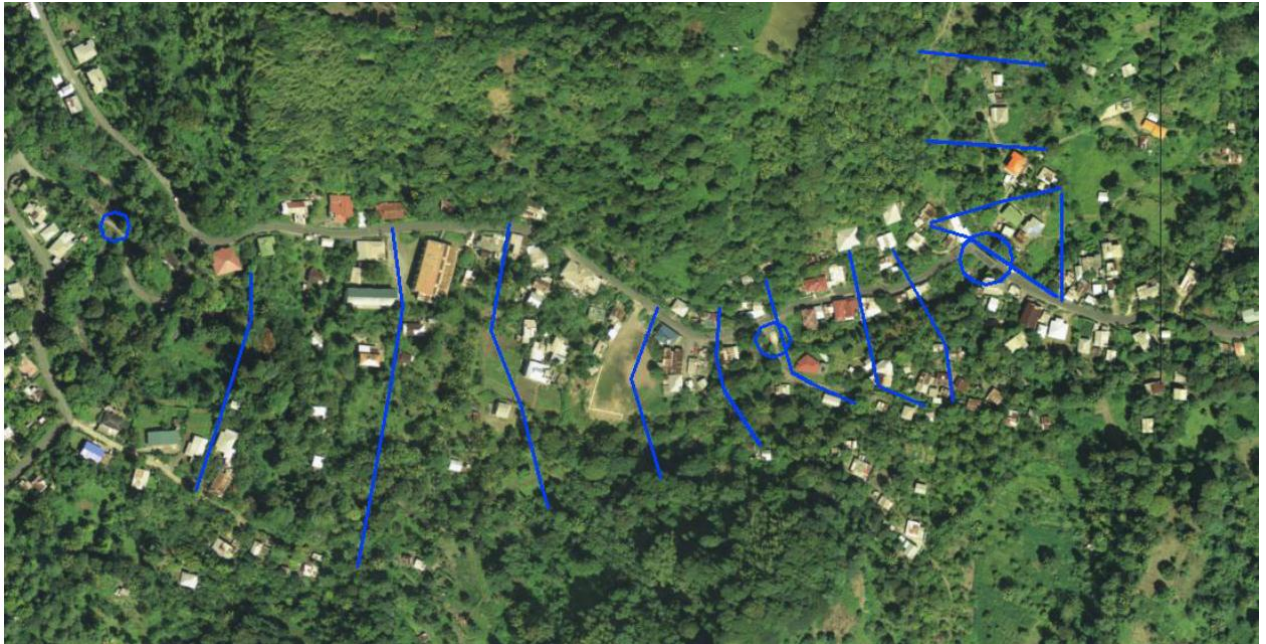

Figure 7 : Land survey in Fond Saint Jacques

The blue lines are the cross sections, the green lines are longitudinal sections (dikes and drains) and the circles correspond to the hydraulic structures (bridges).

We have placed them after the field investigations and the topographical data analysis, to fill the missing data and to allow us after to perform accurate hydraulic models.

We have also asked RSS to measure some water levels during Tomas, picked up during our field investigations (see further in this report).

This recovery of those data will take about two months' time.

See in annex the corresponding term of reference.

Chapter 6. Field investigations

6.1 Dennery

6.1.1 General comprehension

Dennery is situated nearby the Atlantic Ocean, in a flat area surrounded by urbanized hills. The town is drained south by a large river (the Mole river), north by a little ravine (Ravine Trou à l'eau) and the center by an aerial drain network linked with the Mole River.



Figure 8 : *Dennery flood plain, urbanized hills and mouth of the Mole River*

The urbanization is growing year by year and is unplanned. This leads to increase soil sealing, and therefore increase runoff. The rain drains developed in the 50's seems to be now undersized. More, some former wetlands, which used to retain and store rain water, are now filled.

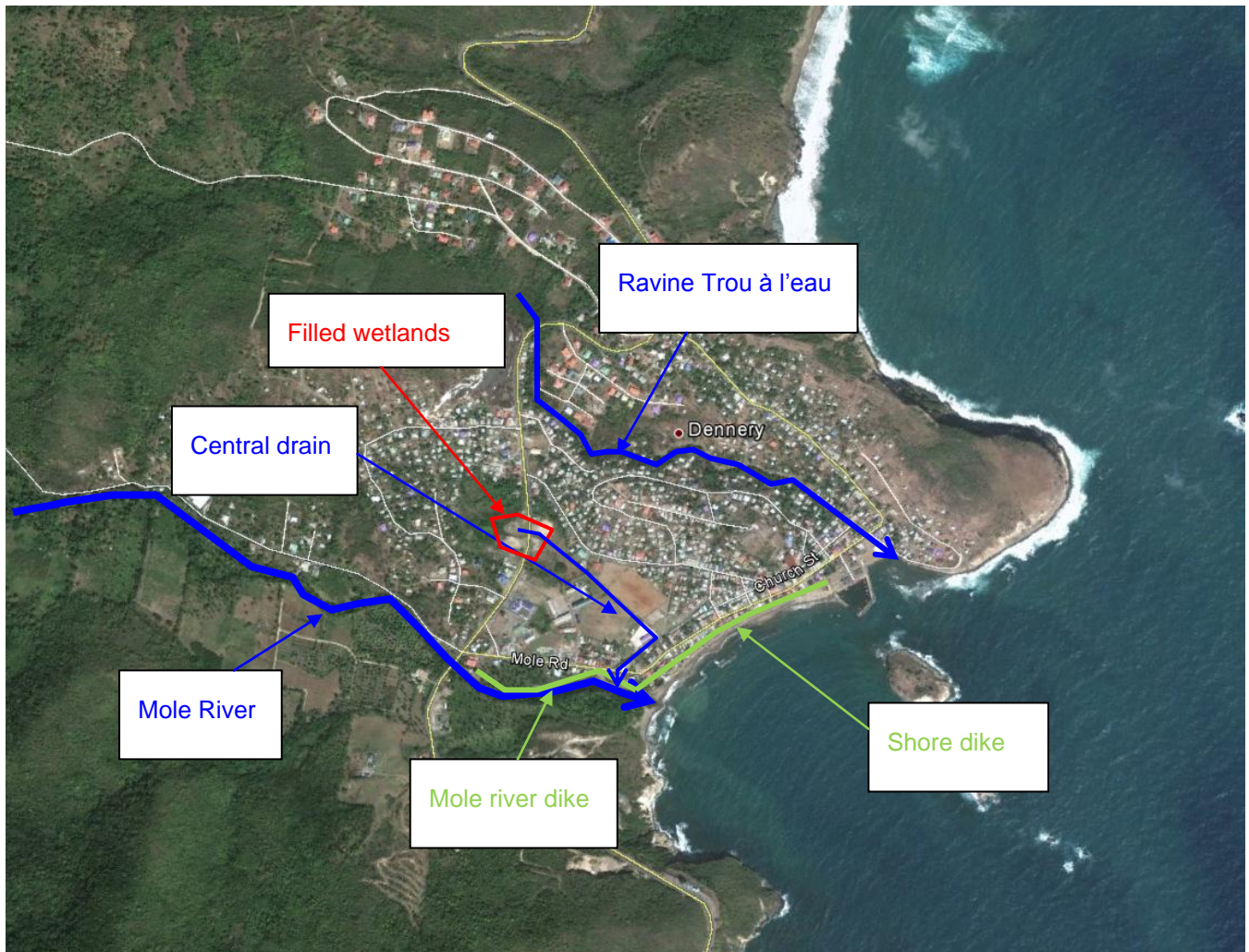

Figure 9 : Dennery drainage system

The Ravine Trou à l'Eau is natural, steep sloped and sinuous upstream, but is a concrete flat drain as soon as it reaches the flat zone downstream. We could see a lot of connection there between the ravine and rainwater network without any anti-backflow system. This may create flooding more often in the neighbourhood when the upstream catchment is having a heavy rain. A lot of bank erosions have been seen during our investigations in the natural part of the ravine : the speed of water there must be high.

In addition with flooding problem we could see a health problem: rainwater network (almost 100% with open channel) is used as a sewer by the citizens. In case of over flooding, it can be a cause of illness.

The Mole river is a large and flat river, coming from a big upstream catchment (from the rainforest part of the island). It hasn't been dredged for years : the invert level have been raised little by little.

After Debby hurricane a dike were constructed along the left bank of the river to protect Dennery. But this dike is not maintained : a lot of trees are growing on it and its top level is not regular : the flow that came over the top of the dike during Tomas must have taken part of it

because it seems lower where people said to us the water came from. Directly downstream of the bridge, there is no dike but a smaller wall.

After Debby another dike have been built along the shore to protect the city from the high sea levels. This dike is made of rocks but there is no maintenance too the top is not regular and now partially silted with sand.

On one hand, those 2 dikes prevent water entering the city from the sea and the Mole river (unless water levels reach the top of them), but on the other hand, they don't allow the city runoff to evacuate properly: rain water is stored behind the dikes, the city of Dennery fills like a storage area because the outlets in the Mole river are not enough and are not working very well.

Dennery village experienced two major floods in October 2010:

- The 5th of October: a local heavy rainfall occurred and saturated the rainwater network as much as it consequently flooded the entire village;
- The 30th of October the tropical cyclone Tomas hit Saint Lucia, with effect on the rainwater network, the Dennery River and the Ravine Trou à l'Eau.

The explanations given by the people interviewed before were confirmed by field investigations and people that we could interrogate in Dennery:

- Flow of the Mole river going over the dike downstream the bridge;
- Mole road use by the flow as a river;
- Cemetery under water;
- Schools under water (about 1.80-02 meter high – the Land Surveyor will measure it);
- Water coming first from the river but also from the main central drain;
- Connection between the rainwater network and the river;
- Flooding in Ravine Trou à l'Eau too
- The sea level was high

The next two photographs were taken during or just after Tomas flooding.

The first one shows the schools during flooding. The second one corresponds to the Mole Road (first road after the dike) after flooding. We can see the presence of lot of mud.

Figure 10 : Photography of Dennery Primary School during Tomas (cimetary in background)



Figure 11 : Silt Deposit after Tomas in Mole Road



6.1.2 Ravine Trou à l'Eau

Next pages show the field investigations from upstream to downstream.

The aerial photography in background isn't updated (2009).

Figure 12 : Field Investigation in Dennerly : Ravine Trou à l'Eau – Photograph index

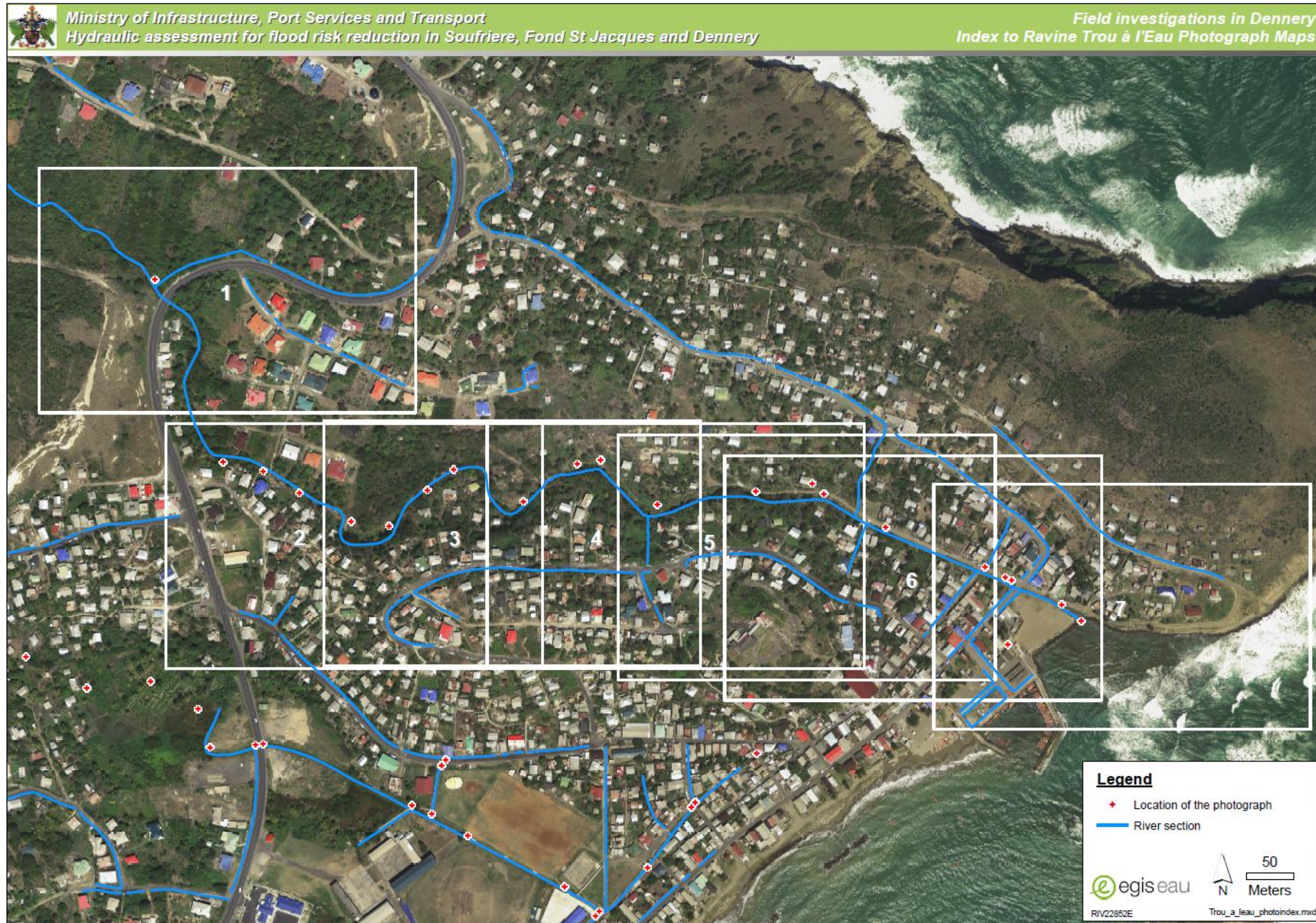

Figure 13 : Field Investigation in Dennerly : Ravine Trou à l'Eau – Plate # 1



Figure 14 : Field Investigation in Dennerly : Ravine Trou à l'Eau – Plate # 2



Figure 15 : Field Investigation in Dennerly : Ravine Trou à l'Eau – Plate # 3



Figure 16 : Field Investigation in Dennerly : Ravine Trou à l'Eau – Plate # 4



Figure 17 : Field Investigation in Dennerly : Ravine Trou à l'Eau – Plate # 5



Figure 18 : Field Investigation in Dennerly : Ravine Trou à l'Eau – Plate # 6



Figure 19 : Field Investigation in Dennerly : Ravine Trou à l'Eau – Plate # 7



6.1.3 Central drain

This drain collects water from a small urbanized catchment area.

The main observations on this network are the followings:

- The system is built in three parts:
 - Upstream catchment: up to the main road (East Coast Road) and to the wetland area. This part generates the flow incoming downtown from the hills. It is a new residential area.
 - Middle part of the catchment: it is a low urbanized area very flat. It has a regulation role for the flow;
 - The final part of the catchment: there is a high density of houses and streets (very impermeable soil conditions). The network takes place along each street.

- The middle part of catchment is becoming more and more artificialized :
 - Big new housing construction just upstream from the East Coast Road;
 - Filling of the wetland area by any kind of materials (rocks, green waste, sand, dirt, ...):
 - Upstream from the East Coast Road
 - Downstream from the East Coast Road

- There are 2 outlets :
 - the major one near the mouth of the Mole River in the ocean (partially destroyed during Tomas), just upstream of the sand accumulation blocking the river flow.
 - A second one, reaching the Mole river downstream the bridge but not working well (going upstream direction and with a valve)

The filling of wetlands has direct consequences on the downstream flow: the flow cannot be stored and regulated. Maximum flow increases.

This effect is increased by the urbanization growing on the hill.

During first October 2010 event, one of the causes of Dennery flooding must be that filled wetlands and the poor drainage infrastructures.

Next pages show the field investigations from upstream to downstream.

The aerial photography in background isn't updated as it dates from 2009.

Figure 20 : Field Investigation in Dennerly : Central Drain – Photograph index

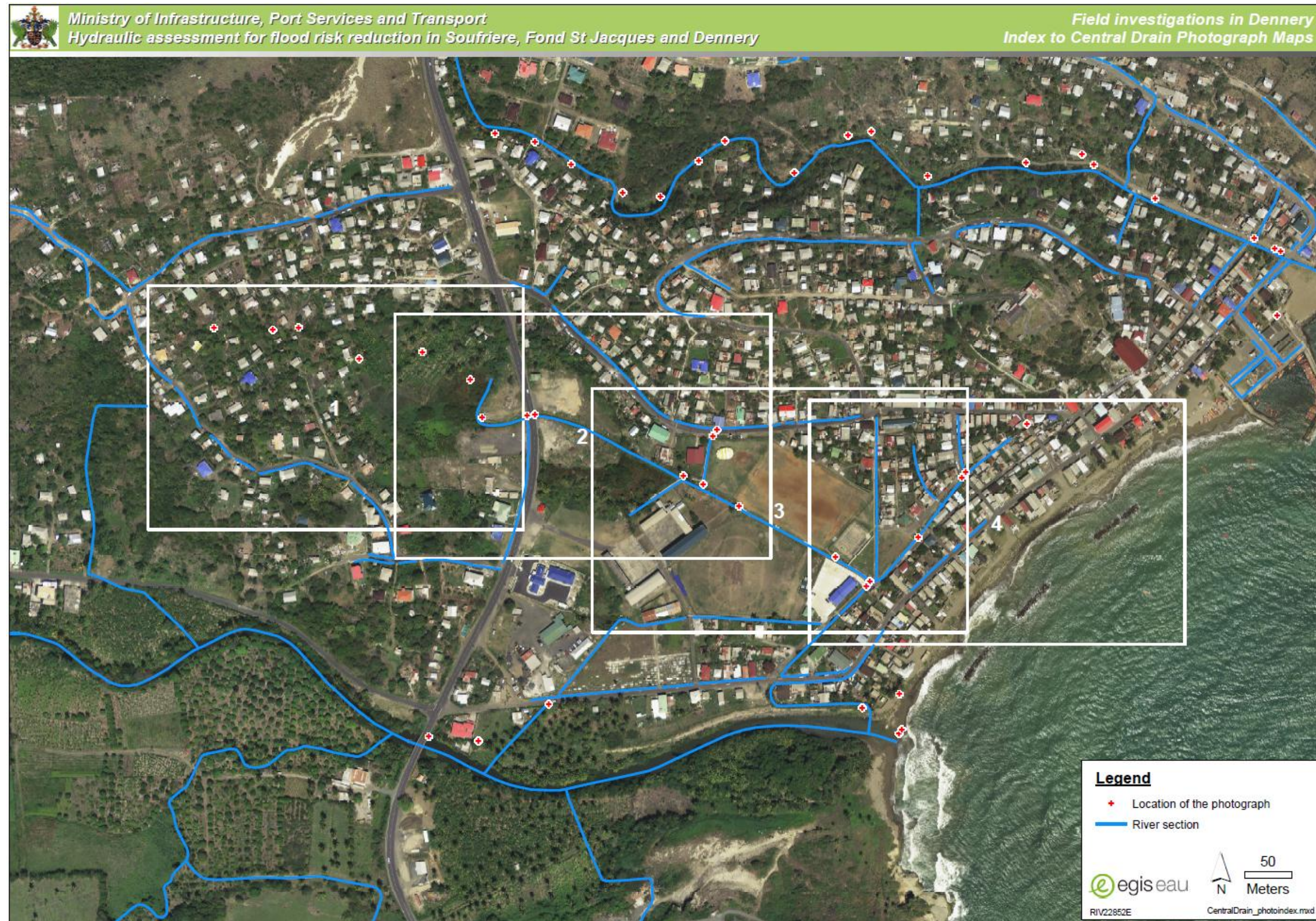

Figure 21 : Field Investigation in Dennerly : Central drain – Plate # 1

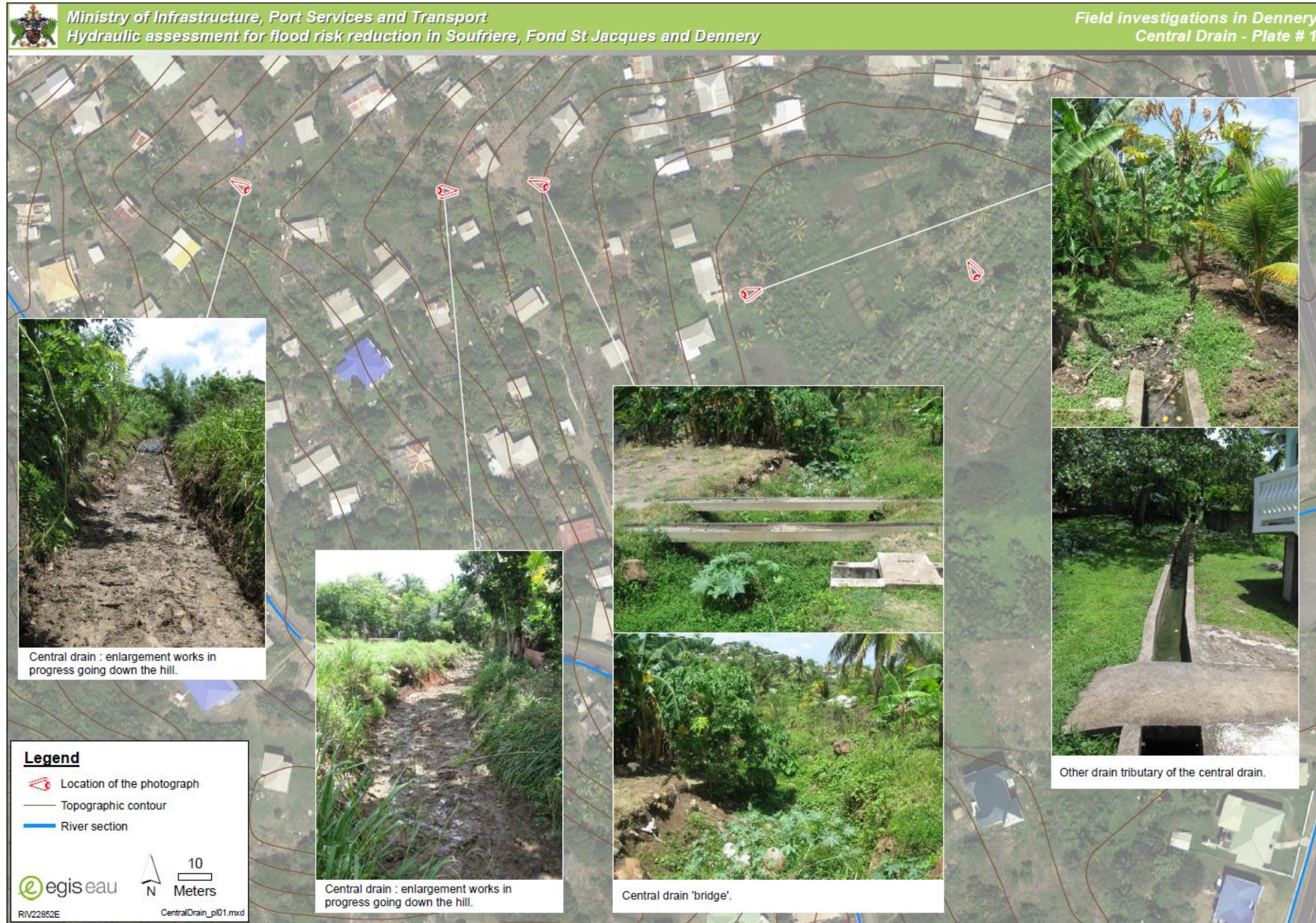

Figure 22 : Field Investigation in Dennerly : Central drain – Plate # 2



Figure 23 : Field Investigation in Dennerly : Central drain – Plate # 3



Figure 24 : Field Investigation in Dennerly : Central drain – Plate # 4



6.1.4 Dennerly River (Mole River)

There are three main problems with the Dennerly River that could be seen or analyzed from the field investigation:

- The left dike doesn't seem to have a regular profile as the upstream part isn't tall enough to contain the river (near the bridge);
- There are 2 connections between the river and the rainwater network from center town;
- The river invert level has increase because of siltation and lack of maintenance.

A lot of vegetation is growing in the left dike and there is no maintenance on it. It can seriously affect its stability (risk of internal erosion, massive destruction if a tree fall dawn...).

The raise of the river invert level occurs when the flow is low : less water speed, creation of a closure at the river mouth. However this siltation cannot be considered responsible for the flooding over the dike, because during a flood, at peak flow, the water velocity evacuates the alluvial deposits to the ocean.

The outlet of central Drain was damaged by the flow during Tomas.

The bridge wasn't overflowed during Tomas and wasn't damage.

This bridge has a central pier which leads to accumulation of debris upstream. This may cause local hydraulic disturbances.

Next pages show the field investigations from upstream to downstream.

The aerial photography in background isn't updated (2009).

Figure 25 : Field Investigation in Dennerly : Ravine Dennerly – Photograph index

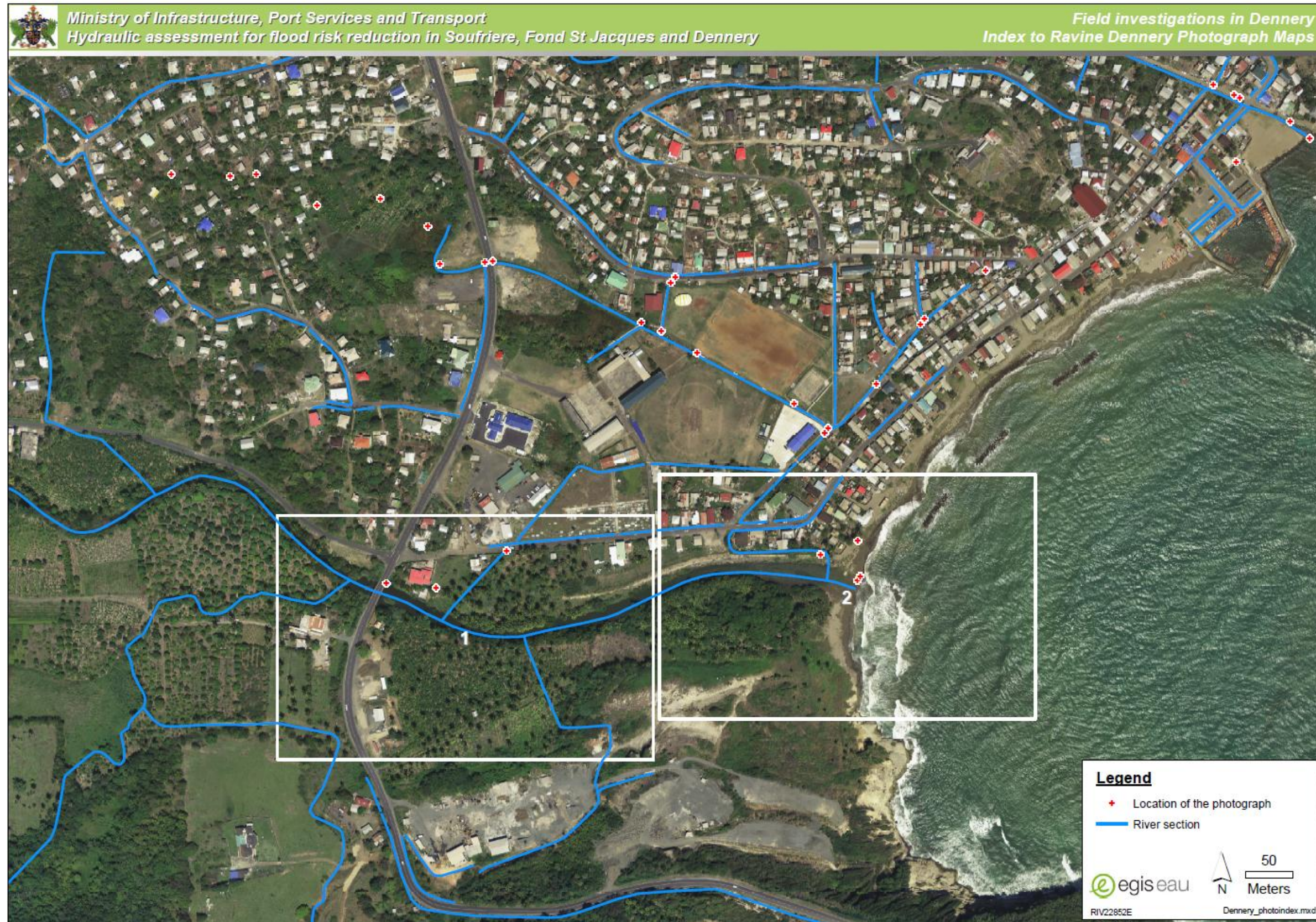

Figure 26 : Field Investigation in Dennerly : Ravine Dennerly – Plate # 1



Figure 27 : Field Investigation in Dennerly : Ravine Dennerly – Plate # 2



6.1.5 Comments

The floods in Dennery can be caused by 3 different ways :

- The overflow on Mole river dike (when the Mole river is flooding, that is to say when there are quite long heavy rain in the central part of the island (Mole river catchment))
- The accumulation of local runoff in town behind the dikes (when there is local and heavy rain)
- The overflow of the shore dike if the sea level is high.

The Dennery field investigations highlight the flood risk increase resulting from unplanned development (construction in the floodplain, backfilling of wetlands and watercourses) and poor drainage infrastructure.

More, there is no maintenance of the rivers, drains and hydraulic structure (bridges, dikes ...).

All the drainage infrastructures were designed before Tomas in Dennery, and that hurricane highlighted the fact that they are no longer adapted to the high flow that can occur.

The hydraulic capacity of the drains and river channels will be provided in the report #2 (hydraulic modeling).

Geological and Topographical analysis will be provided in the report 2 (hydrological study)

6.2 Fond Saint Jacques

6.2.1 General comprehension

Fond Saint Jacques is located at the head of the watershed of Soufriere, between the altitude 300 m and 600 m.

The catchment surface area is approximately 1km², which is not very big, but it is situated in the mountainous central part of the island, where heavy rain can often occurs. The catchment is made of very steep slopes covered with rain forest.

Fond saint Jacques community is settled in bottom of a pretty narrow ravine, between the waterway and the steep slopes of the mountains behind.

The main problem during Tomas hurricane was not so much with the water flow as with the mud and debris flow, and the unplanned urbanization: a lot of houses are too close from the waterway, at the bottom of the valley.

Debris flow provided big jams problem under each bridge across the river as we can see on the next photographs:

Figure 28 : photography of Fond Saint Jacques upstream bridge (road to Migny)



Figure 29 : photographs of Fond Saint Jacques downstream bridge (Mochas' bridge) just after Tomas and after cleaning



Those huge quantities of mud, trees and rocks came from important landslides in the upper forest reserve and are a consequence of 24 hours raining (550 mm registered in Union and 593 mm in Hewanorra Airport).

Next photographs were taken by government or consultant (see data collected table) and show the extent of the damage.

Figure 30 : photographs of Fond Saint Jacques damages just after Tomas



6.2.2 Field investigations

Next pages show the field investigations upstream to downstream.

The aerial photography in background isn't updated (2009).

During Tomas the mud and debris flows filled entirely the natural waterways and the hydraulic sections under the 3 bridges located in that community. All the bottom of the valley was overflowed. The water ran down the road with high velocity, damaging all the houses along that road. The water levels were high too because of the channel filling; it reaches sometimes the 2nd floor of the houses.

After Tomas the watercourses were re-dug entirely. The bridges were cleared to. The Migny road bridge was put back on its abutments.

The downstream bridge (Mocha's bridge) was demolished and is presently being rebuilt, without a central pier (see below).

Figure 31 : photographs of actual Mocha's bridge rebuilt



Figure 32 : Field Investigation in Fond Saint Jacques : Photograph index

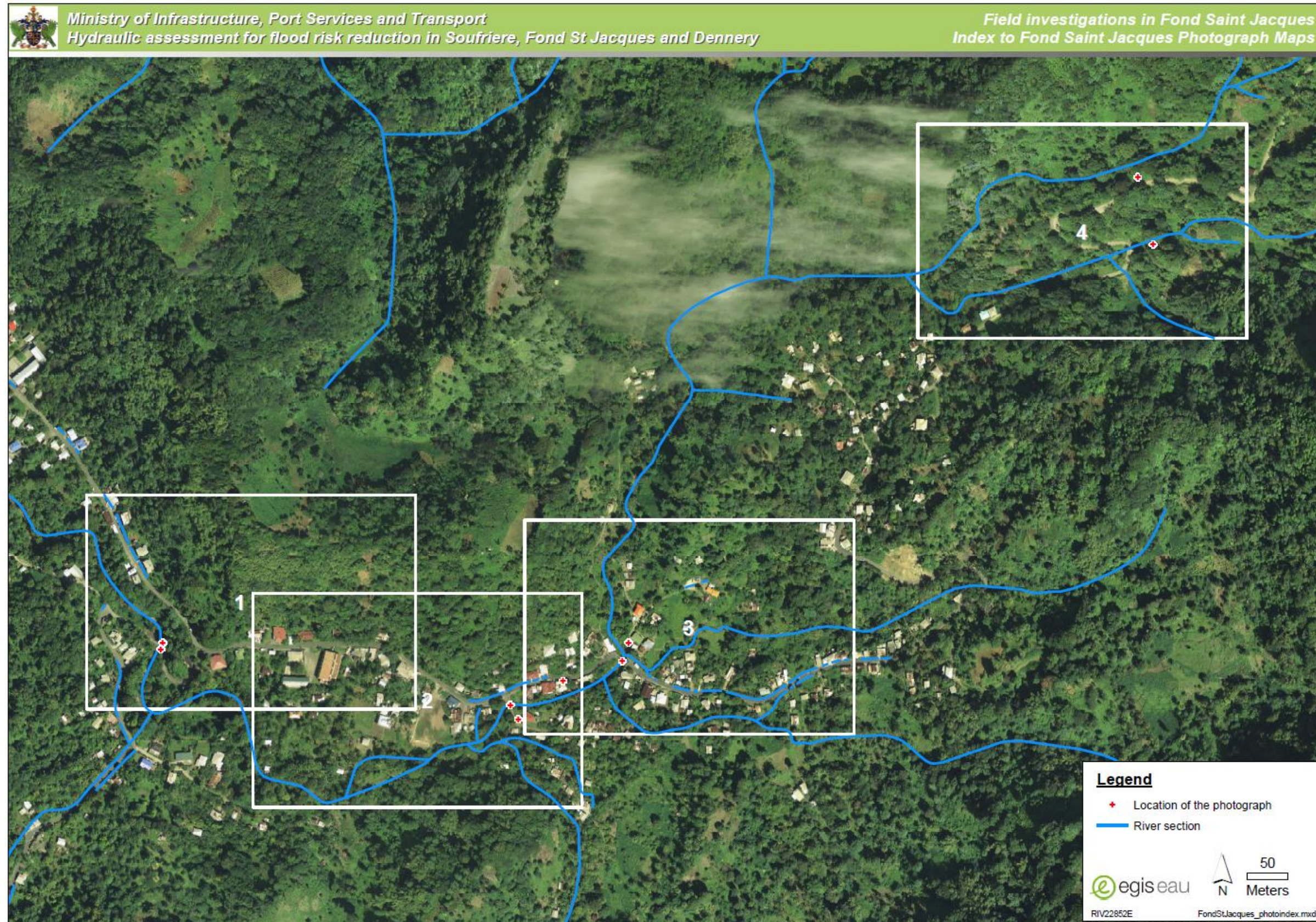

Figure 33 : Field Investigation in Fond Saint Jacques : Plate # 1



Figure 34 : Field Investigation in Fond Saint Jacques : Plate # 2

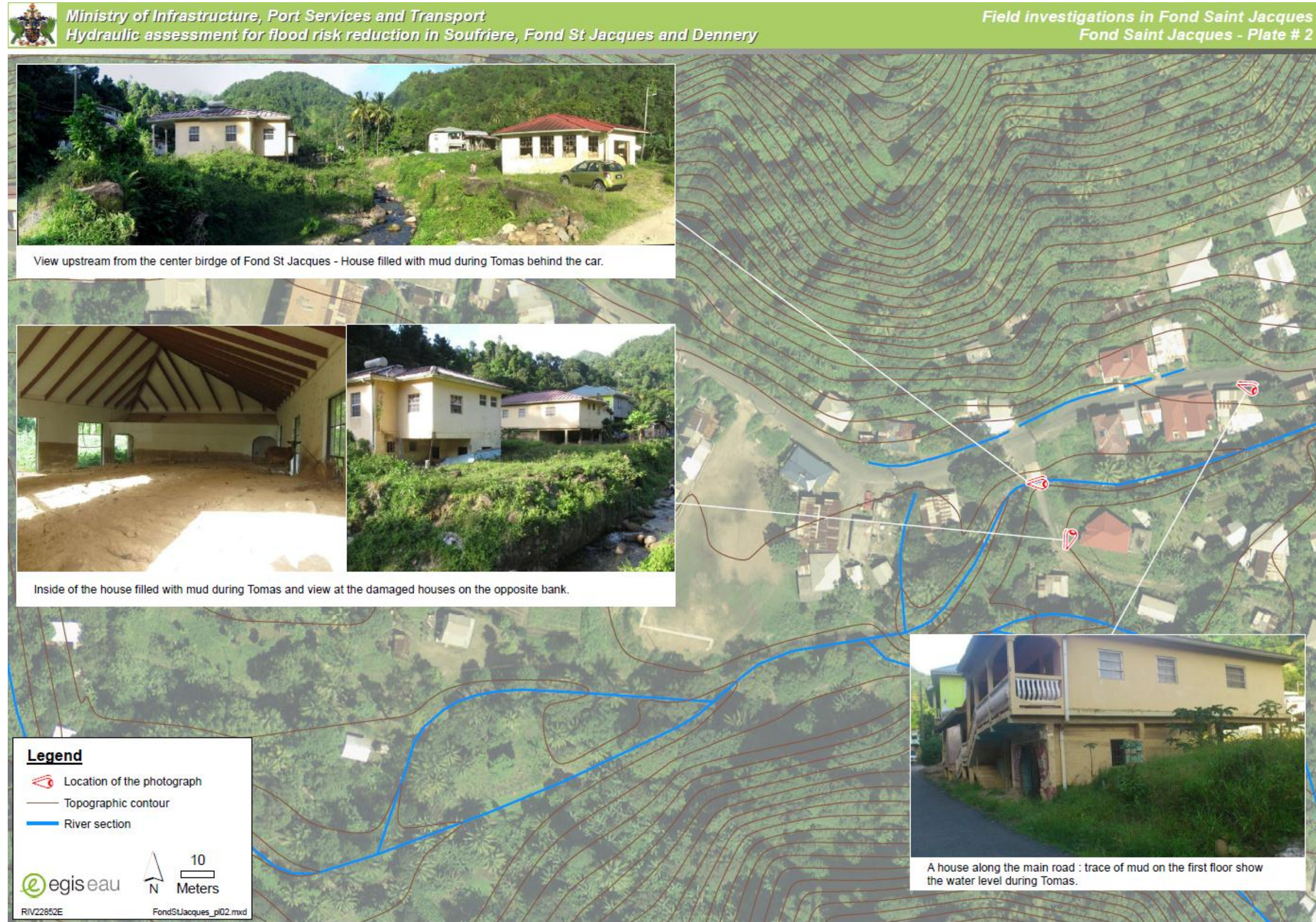

Figure 35 : Field Investigation in Fond Saint Jacques : Plate # 3



Figure 36 : Field Investigation in Fond Saint Jacques : Plate # 4



6.2.3 Comments

The floods in Fond Saint Jacques are “flash-floods” and “mud-floods” caused by heavy rain on the rainforest steep sloped catchment. The velocity is very high and the water levels can reach the 2nd floor of houses built too close from the waterway.

The topographical analysis (steep slopes) and the deforestation increase the risk of landslides, which can fill entirely the waterways and worsen floods effects in the community.

The Fond saint Jacques field investigations highlight the flood risk increase resulting from unplanned development (construction in the bottom of the valley too close from the waterway) and improper forest management.

All the waterway has been re-dug, and a new bridge is being built after Tomas in order to improve hydraulic capacity.

The hydraulic capacity of the drains and river channels will be provided in the report #2 (hydraulic modeling).

Geological and Topographical analysis will be provided in the report 2 (hydrological study).

6.3 Soufriere

6.3.1 General comprehension

Soufriere is located along the Caribbean Sea, in a flat area, at the end of the watershed, downstream Fond Saint Jacques catchment area.

The river is rocky natural upstream the town of Soufriere and is artificial (a large concrete channel) when it pass through the town to the sea. But this channel increases the velocity of the flow. And in many curves, because of the quantity of water and its power, the flow was going right over the riverbank, cutting across the channel, causing flash flooding of the hospital and town (the flow destroyed many houses).

There is lack of maintenance because of debris, sand and rocks deposit in the watercourse, especially at its mouth.

The main problems during Tomas hurricane were caused by water flow, debris flow and high sea level.

Indeed, debris flow provided big jams problems under each bridge and footbridge across the river and caused flooding and infrastructure damages.

The two footbridges were submerged and destroyed during Tomas. They are now rebuilt, higher than before. The bridges upstream and downstream have been rebuilt too after Tomas because damaged during the flood.

After Tomas, the waterway has been dredged, and all the rocks are now deposited along the channel bank. If another flash flood happens those rocks would cause a lot of damages.

The two following pictures show the river and the town during and after Tomas.

Figure 37 : Soufriere River beside the hospital during Tomas



Figure 38 : Silt deposited in the town by Tomas



6.3.2 Field investigations

Next pages show the field investigations from upstream to downstream.

The aerial photography in background isn't updated (2009).

Figure 39 : Field Investigation in Soufriere : Photograph index

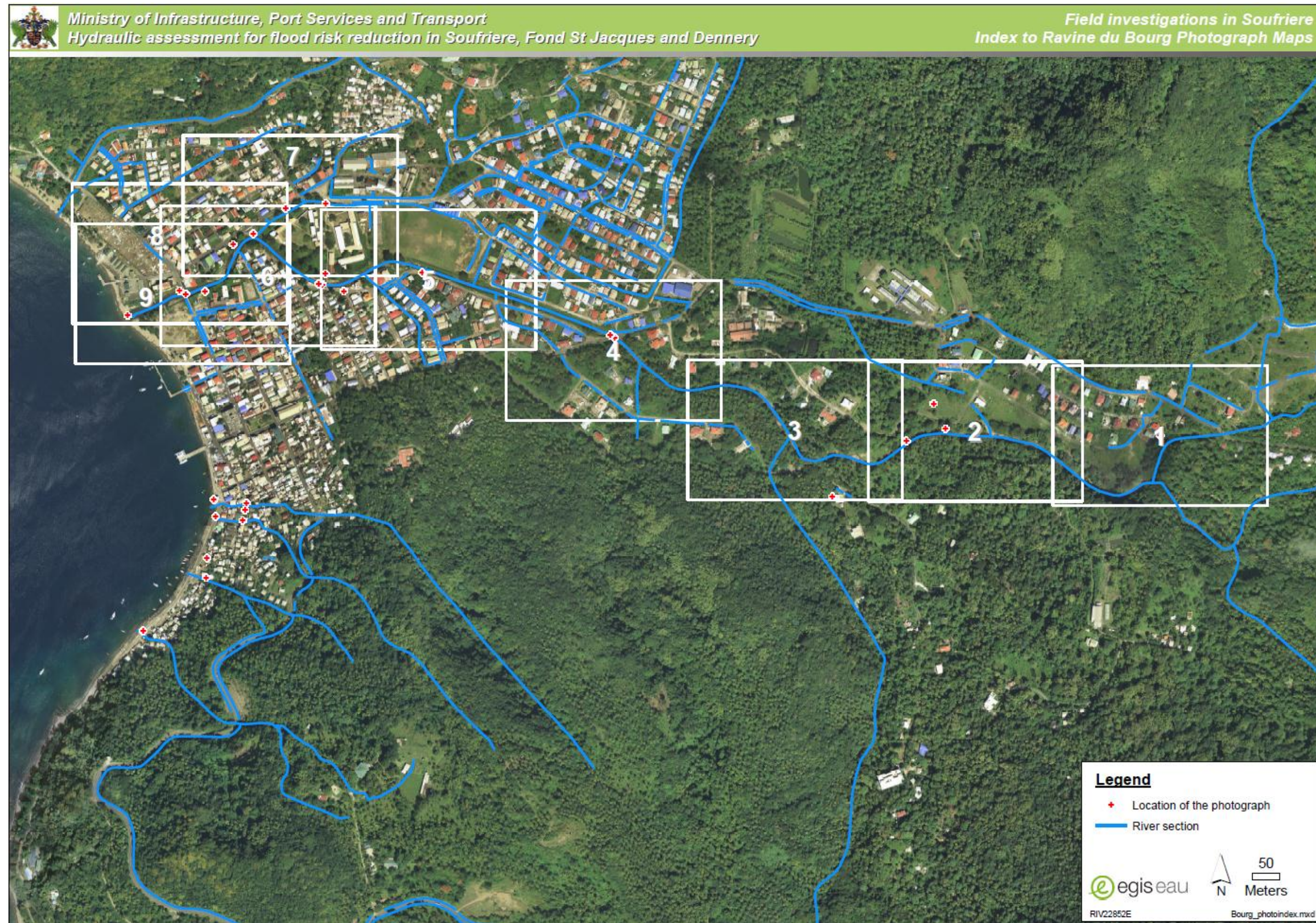

Figure 40 : Field Investigation in Soufriere : Plate # 1

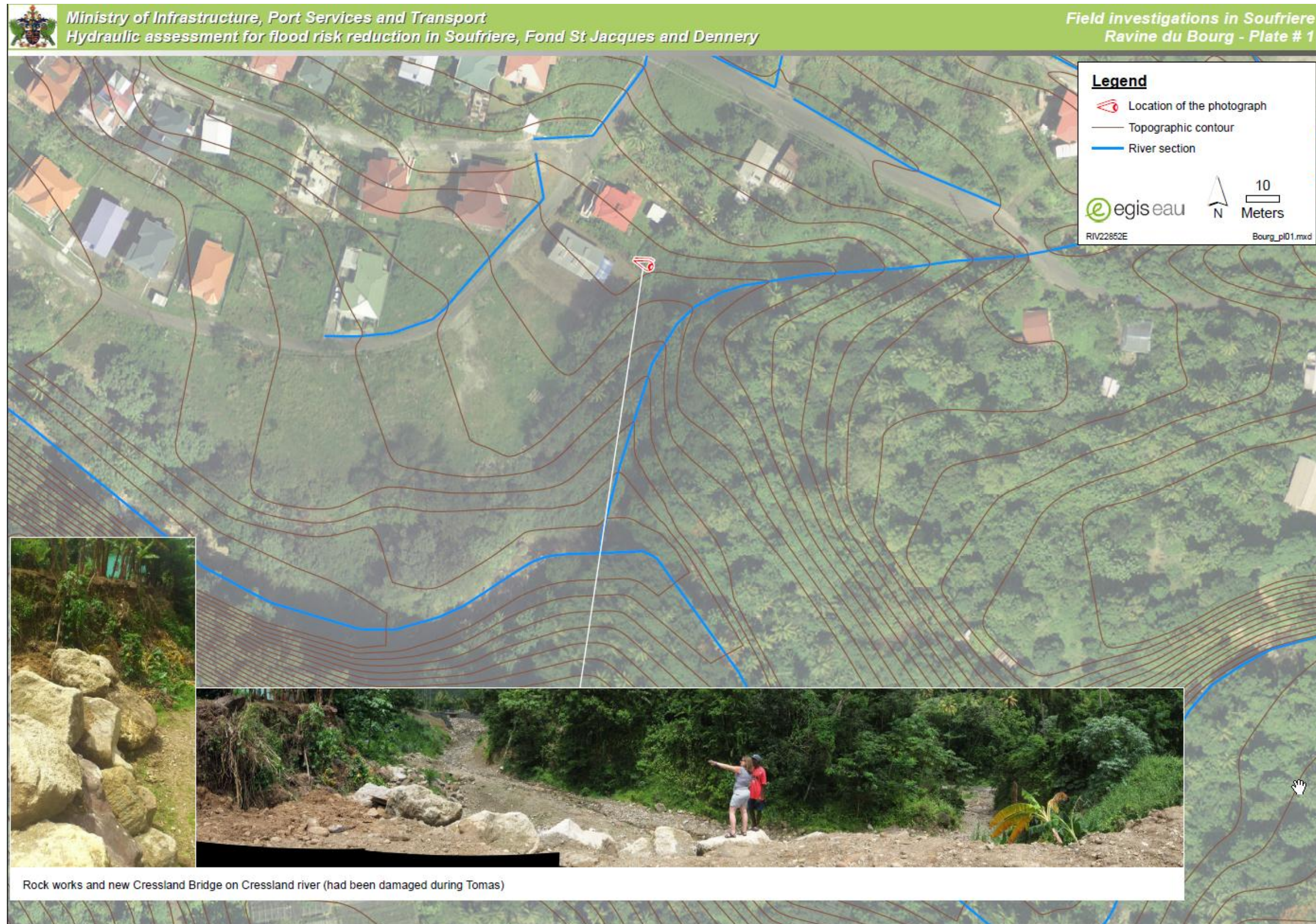

Figure 41 : Field Investigation in Soufriere : Plate # 2

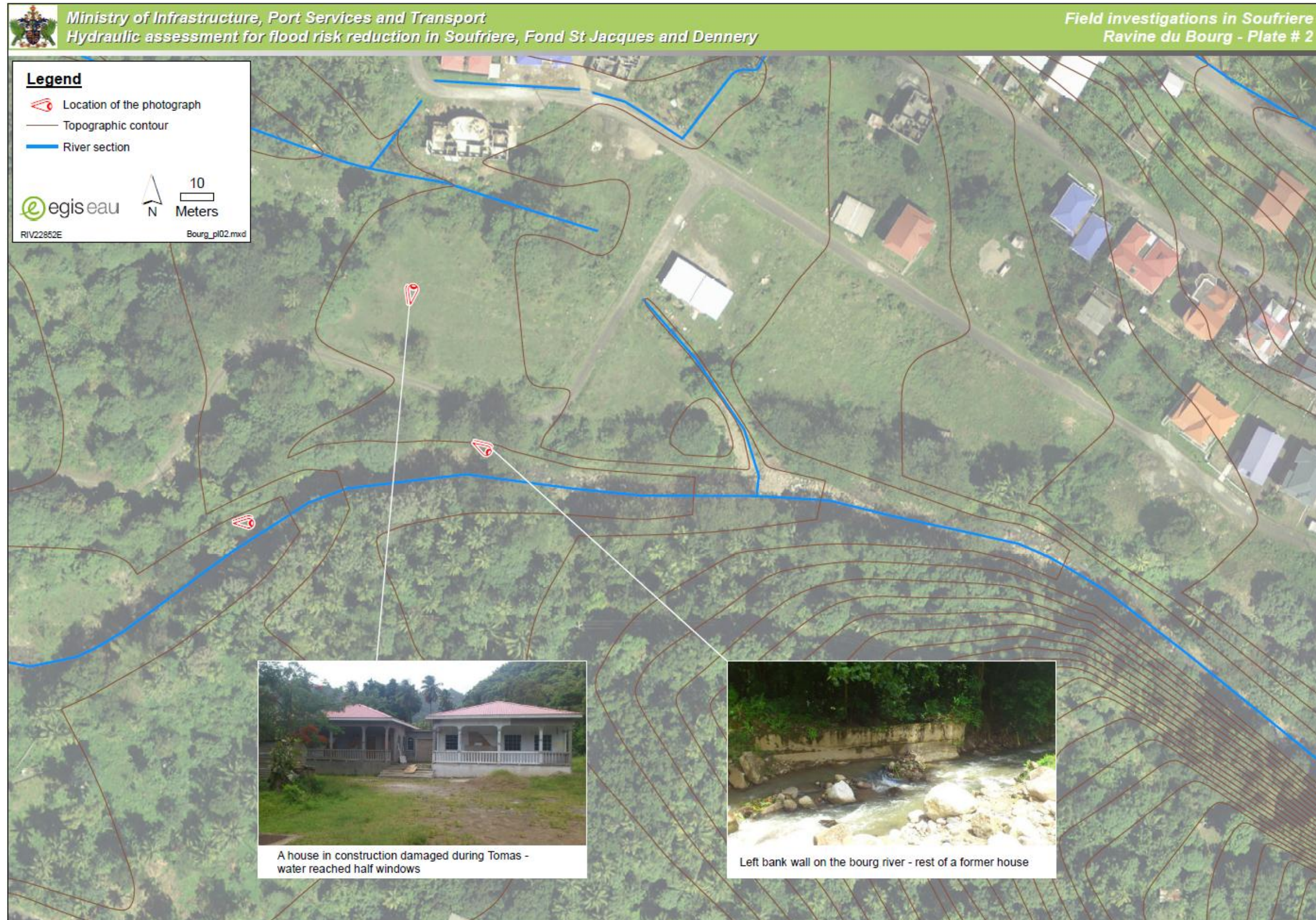

Figure 42 : Field Investigation in Soufriere : Plate # 3

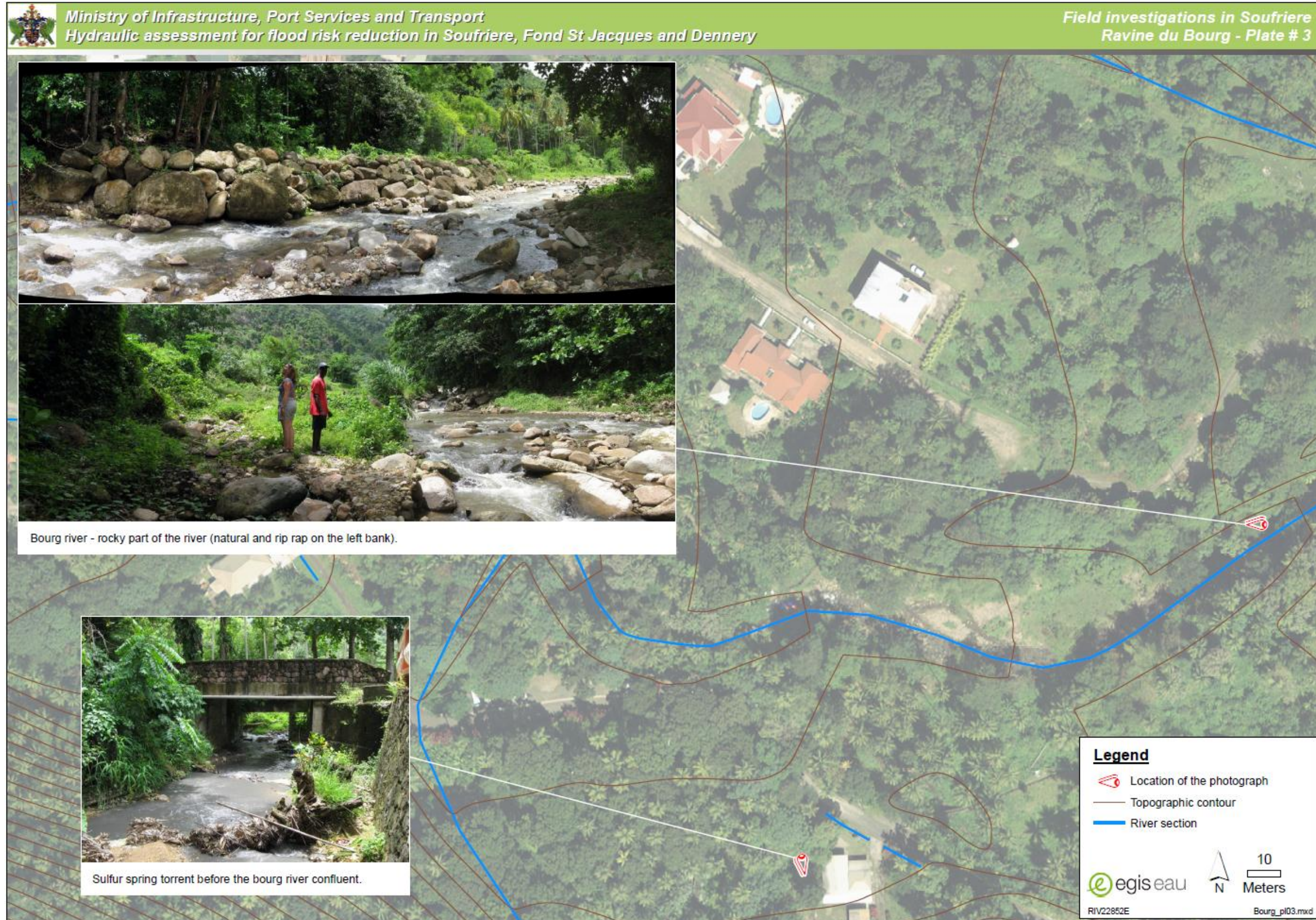

Figure 43 : Field Investigation in Soufriere : Plate # 4



View upstera (natural), downstream (artificialised ; houses) and the bridge when the bourg river enter in Soufriere town.

Figure 44 : Field Investigation in Soufriere : Plate # 5



Figure 45 : Field Investigation in Soufriere : Plate # 6



Figure 46 : Field Investigation in Soufriere : Plate # 7



Figure 47 : Field Investigation in Soufriere : Plate # 8



Figure 48 : Field Investigation in Soufriere : Plate # 9



Chapter 7. Issues and vulnerability first analysis

7.1 Methodology

The vulnerability analysis is based on the GIS data provided by Ministry of Physical Development and on the field investigations.

The following issues had been mapped in each community:

- Public buildings (Schools, Police offices , hospitals, ...);
- Public infrastructures (main roads secondary roads, bridges, gas supply ...)
- Types of housing (residential, density housing)

The field investigations and the photogrammetry data allowed us to define the floodplain area for each community.

Please note that this flood plain delineating is not precise. The real floodplain mapping will be given in the report #2 after hydrological and hydraulic modelling.

The vulnerability analysis is the cross-checking data of the floodplain and the issues. It will be updated in the report #2 when the floodplain will be exactly known.

7.2 Maps

See Next pages :

- The issues mapping.
- The floodplain mapping

All the buildings and roads in the floodplain are vulnerable.

The flood mitigation measures will be given in the reports #3 and #4, but for example, a first measure would be to let the actual natural zones undeveloped.

The aerial photography in background isn't updated (2009).

Figure 49 : Issues in Dennerly

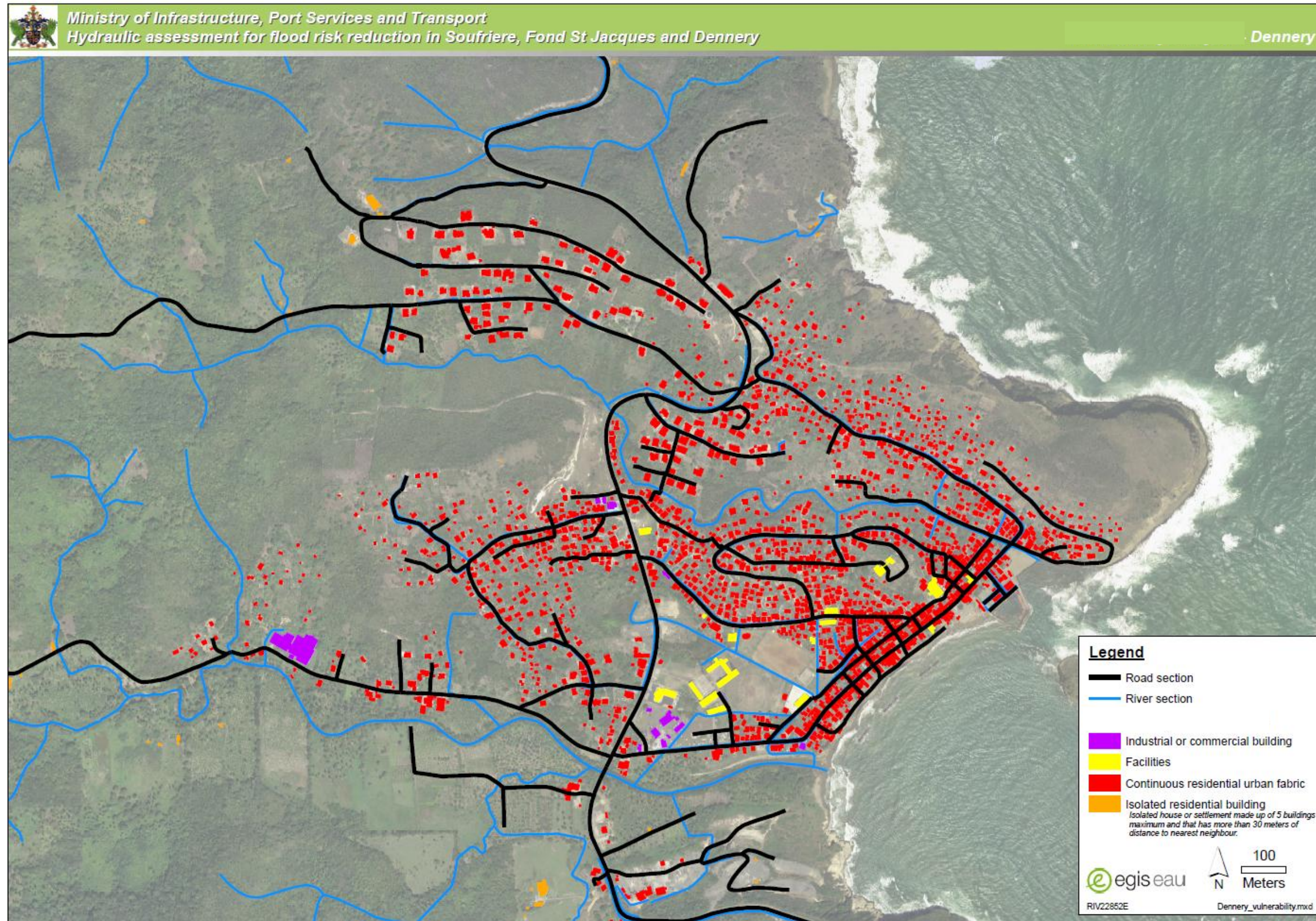

Figure 50 : Issues in Fond Saint Jacques

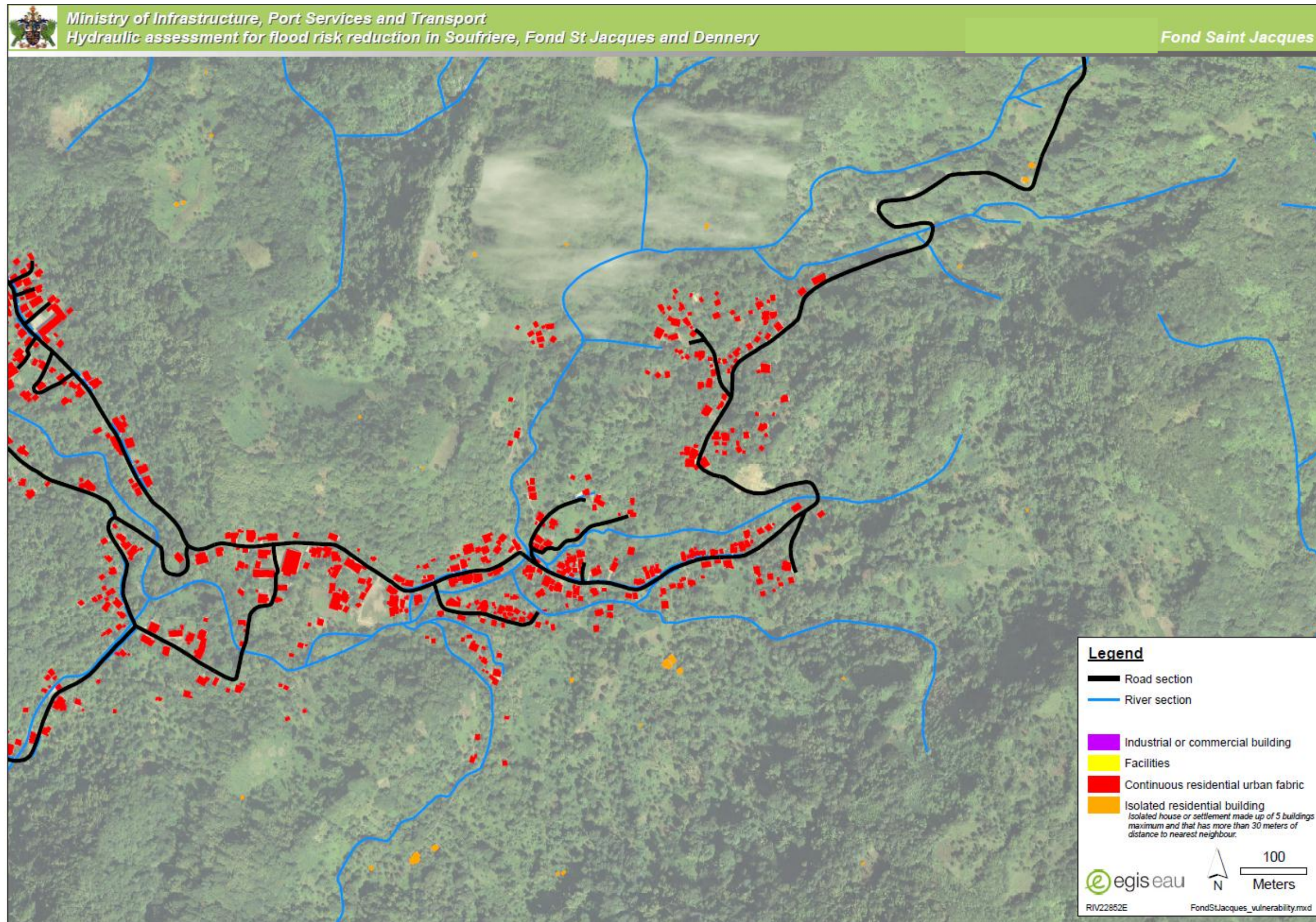

Figure 51 : Issues in Soufriere

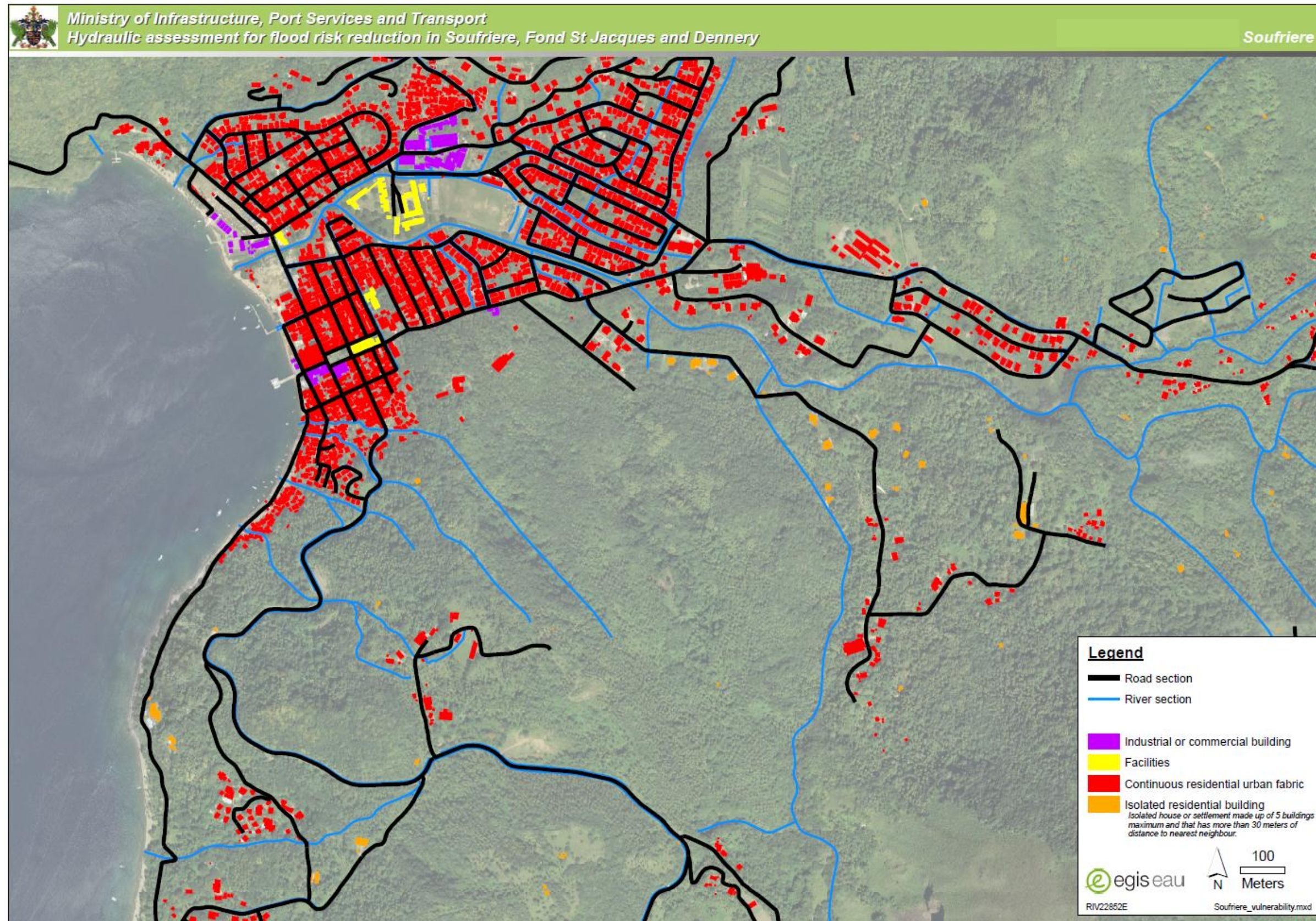

Figure 52 : Dennerly floodplain (field investigation)

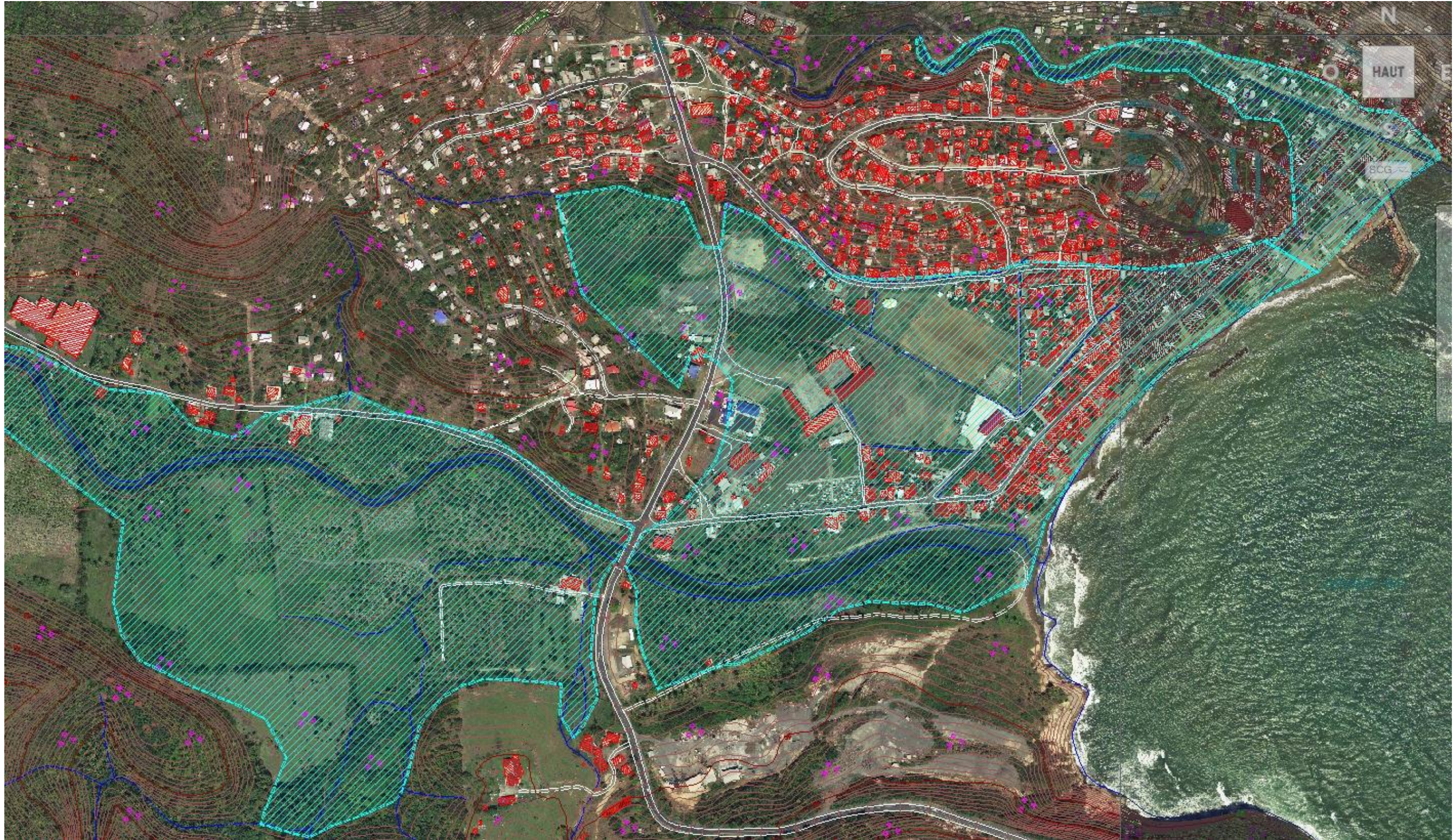

Figure 53 : Fond Saint Jacques floodplain (field investigation)

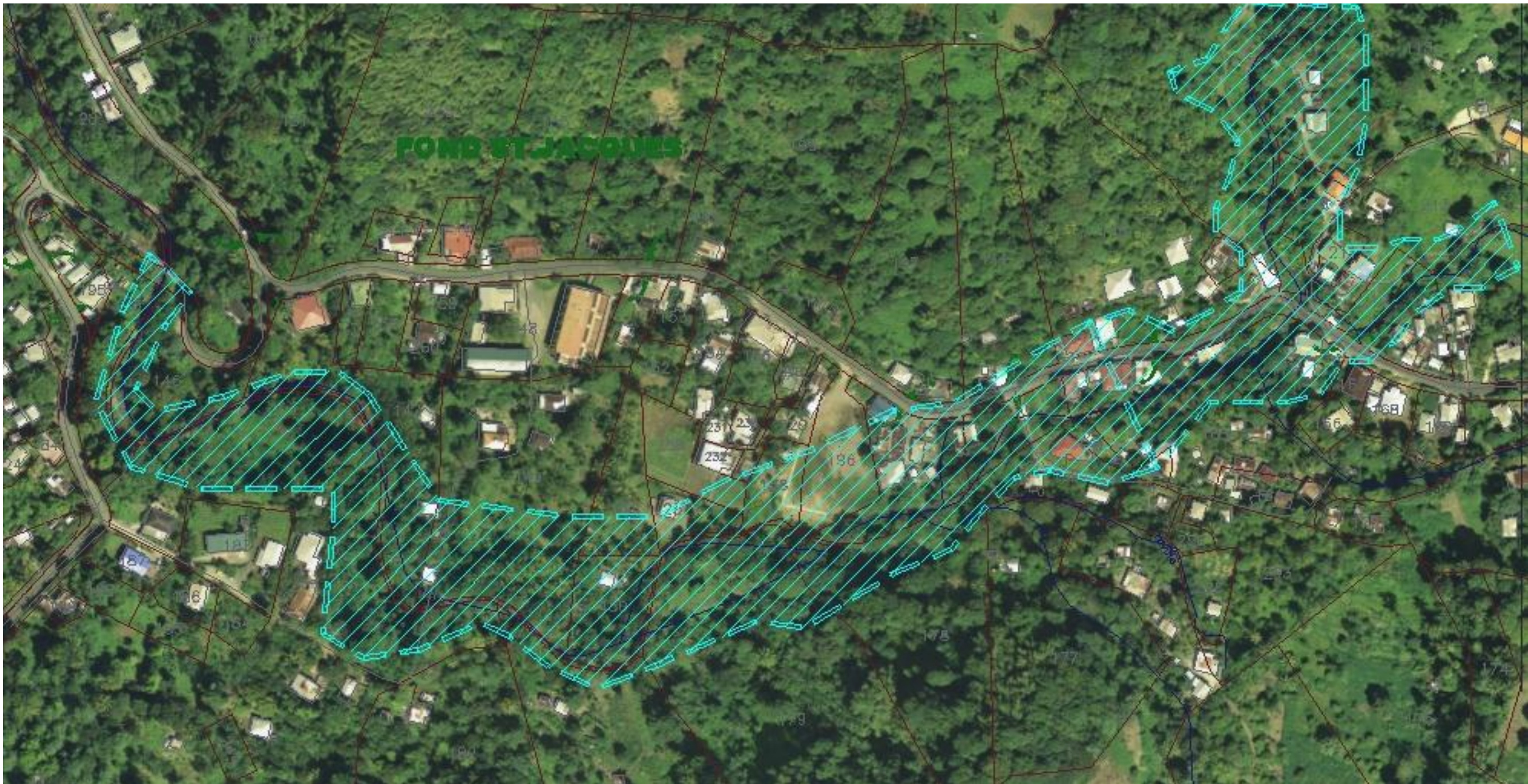
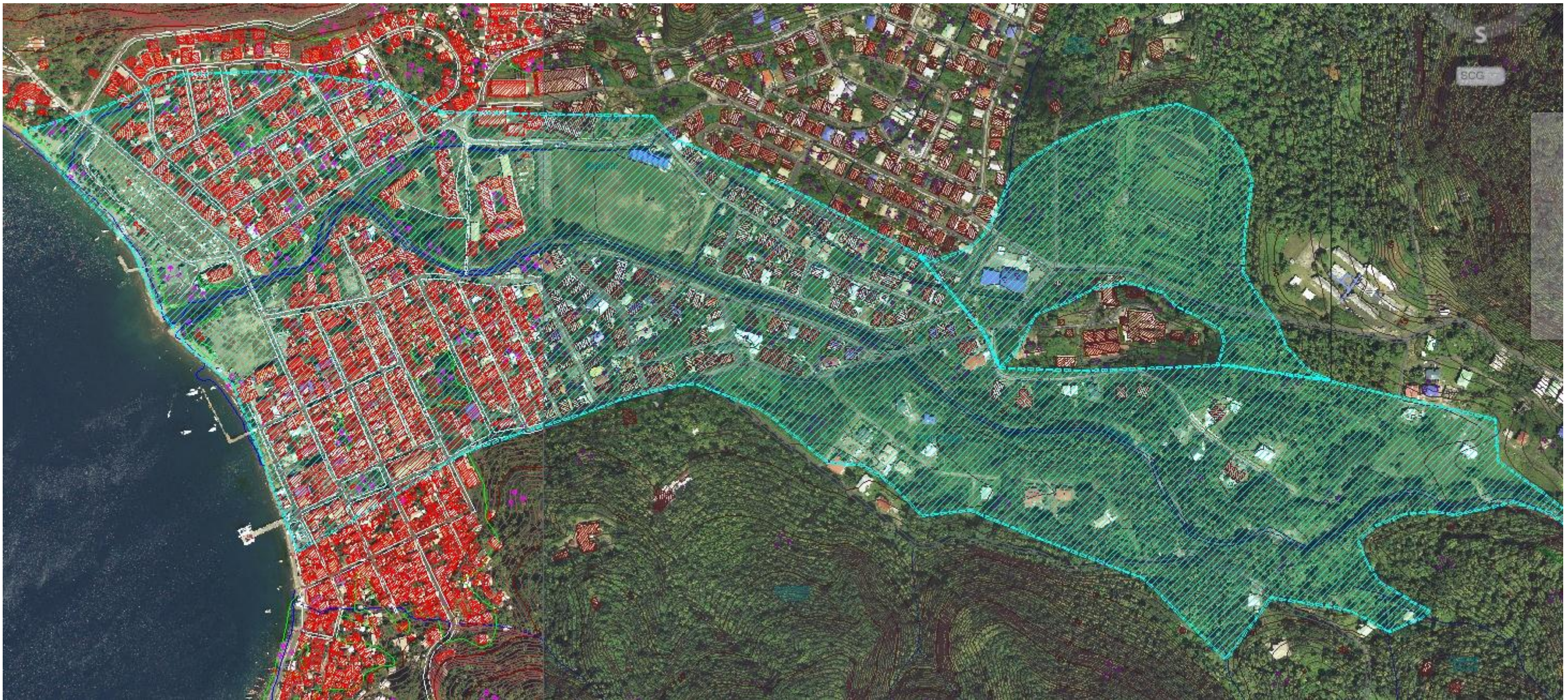

Figure 54 : Soufriere floodplain (field investigation)



ANNEX 1

Topography technical requirements

Chapter 1. Cross sections

1.1 Localization

The Cross section analysis concerns three areas: Soufriere, Fond Saint Jacques and Dennery. See blue lines on the maps p 7, 8 and 9 for their localization.

- 22 cross sections in Soufriere;
- 13 cross sections in fond Saint Jacques;
- 27 Cross sections in Dennery.

1.2 Scope of services

Every cross section will have a minimum of one point every 10 meters.

Every cross section will be taken from the left bank to the right bank.

In the floodplain, it has to describe the land topography in the section as expected in the localization Map; particularly, it will define every change in altitude of the ground (about 5 cm difference).

In the riverbed, it has to describe the shape of the river, as shown on the examples below:

Simple section :

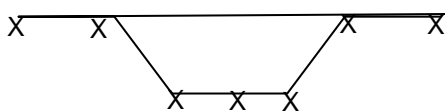

Section with levee:

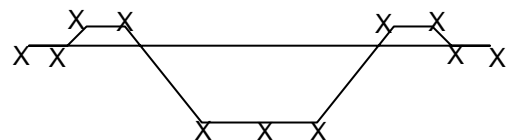

Section with berms :

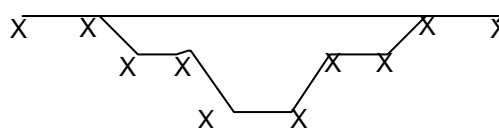

Nota:

For the cross section D1 in Dennery, the block levee that is present on the waterfront has to be measured on its top.

An example of cross section is shown below :

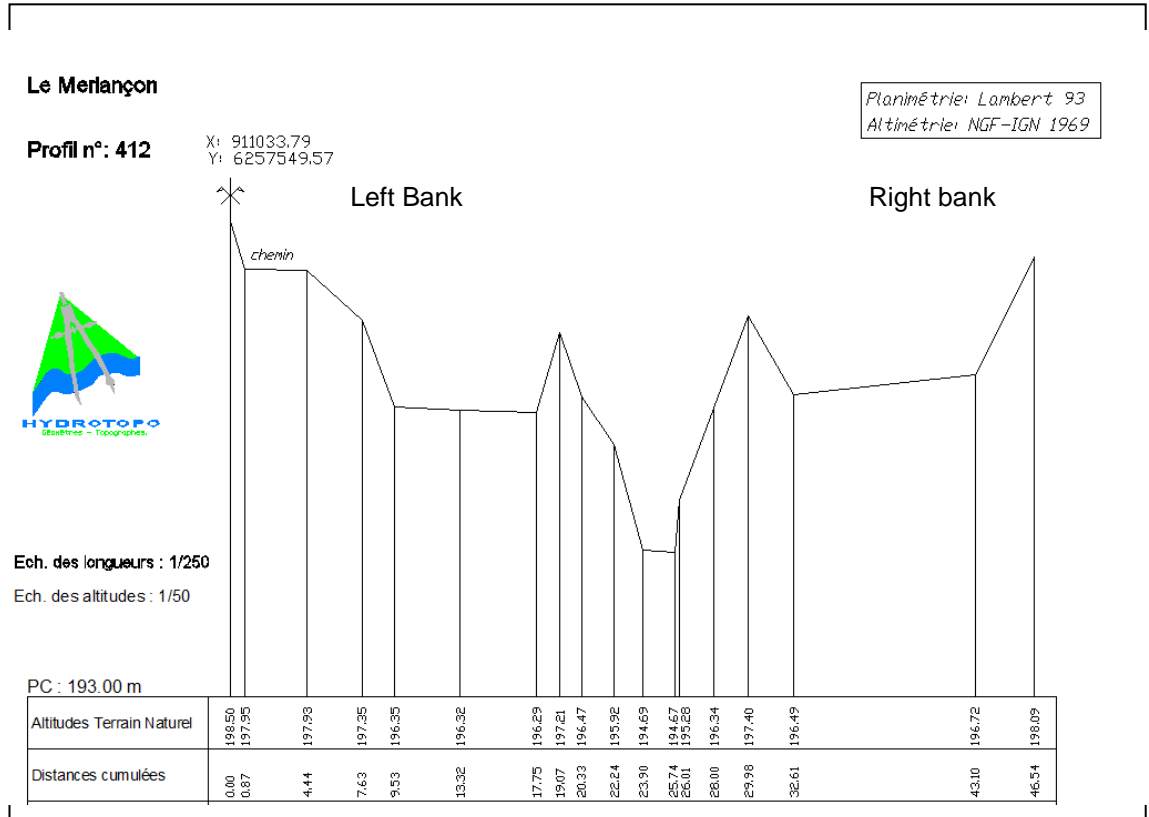

Chapter 2. Hydraulic structures (Bridge – culvert)

2.1 Localization

The Hydraulic structures analysis concerns three areas: Soufriere, Fond Saint Jacques and Dennerly.

See blue rounds on the maps p 7, 8 and 9 for their localization.

- 4 structures in Soufriere,
- 3 structures in Fond Saint Jacques,
- 3 structures in Dennerly

2.2 Scope of services

Every structure must describe the open-section and must be taken at its upstream side.

The following data must be measured:

- the invert level (upstream and downstream)
- the soffit level,
- the road level
- the width measured perpendicular to the flow
- the length of structure

Examples :

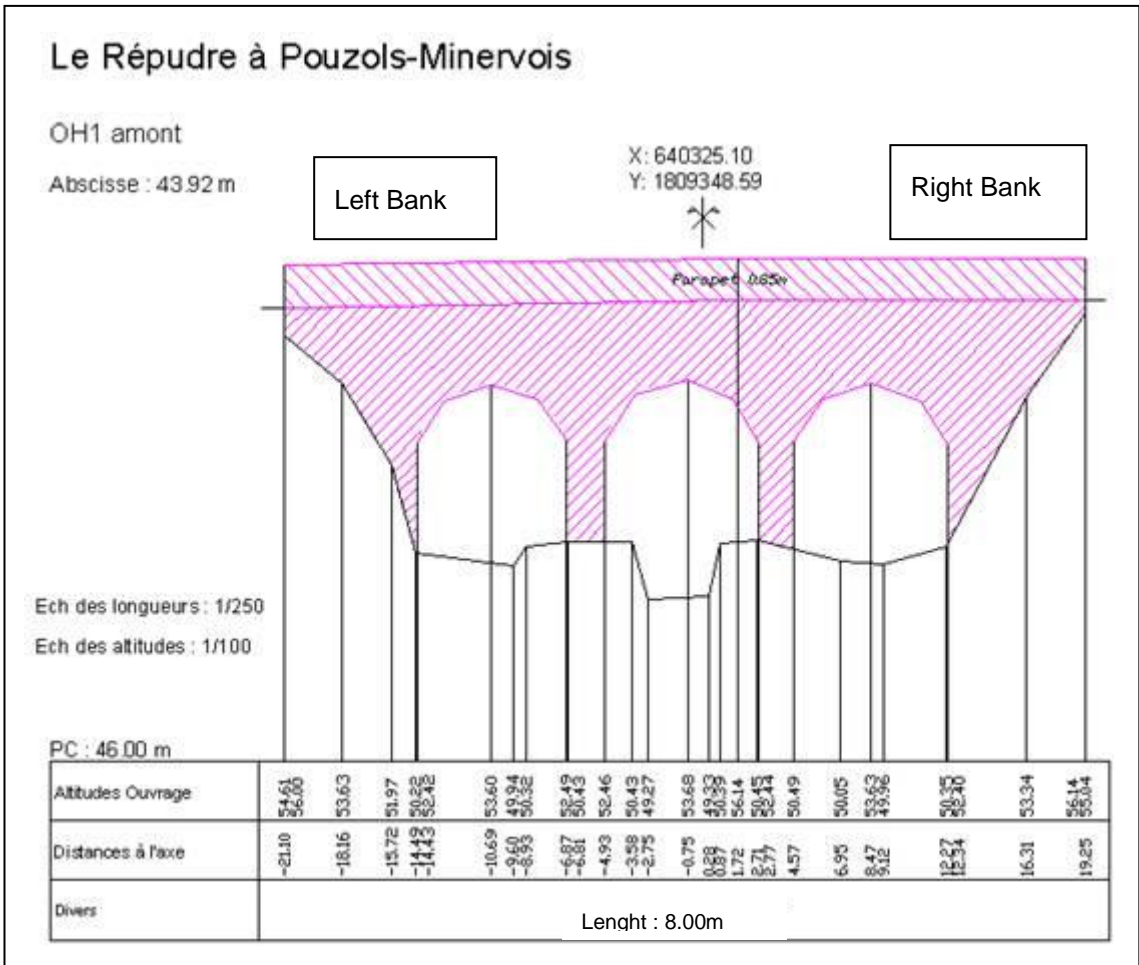

Or

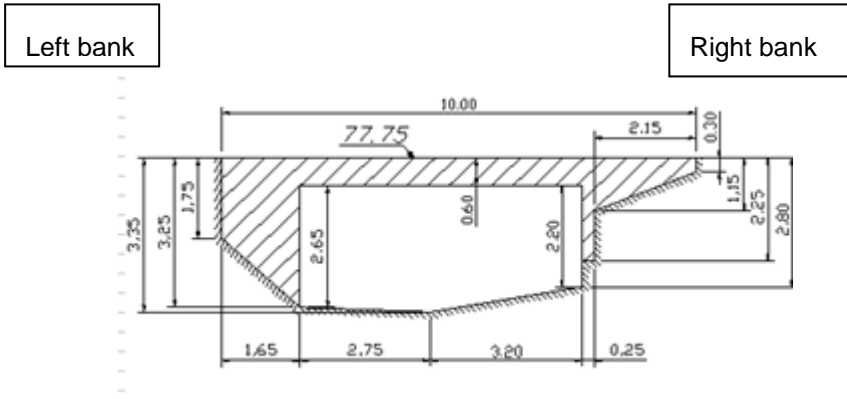

Chapter 3. Longitudinal profile

3.1 Localization

The Longitudinal analysis concerns the areas of Dennery, with 4 profiles to determine.
See the green lines on the map p 9 for their localization.

3.2 Scope of services

Three types of profiles are demanded:

- 3 Channel longitudinal profiles
- 1 Levee longitudinal profiles

For the first categorie the invert level has to be measured.
For the levee : le lowest points of the top.

Every profile will have a minimum of one point every 10 meters.

Cross sections and bridges structures localization in FOND SAINT JACQUES

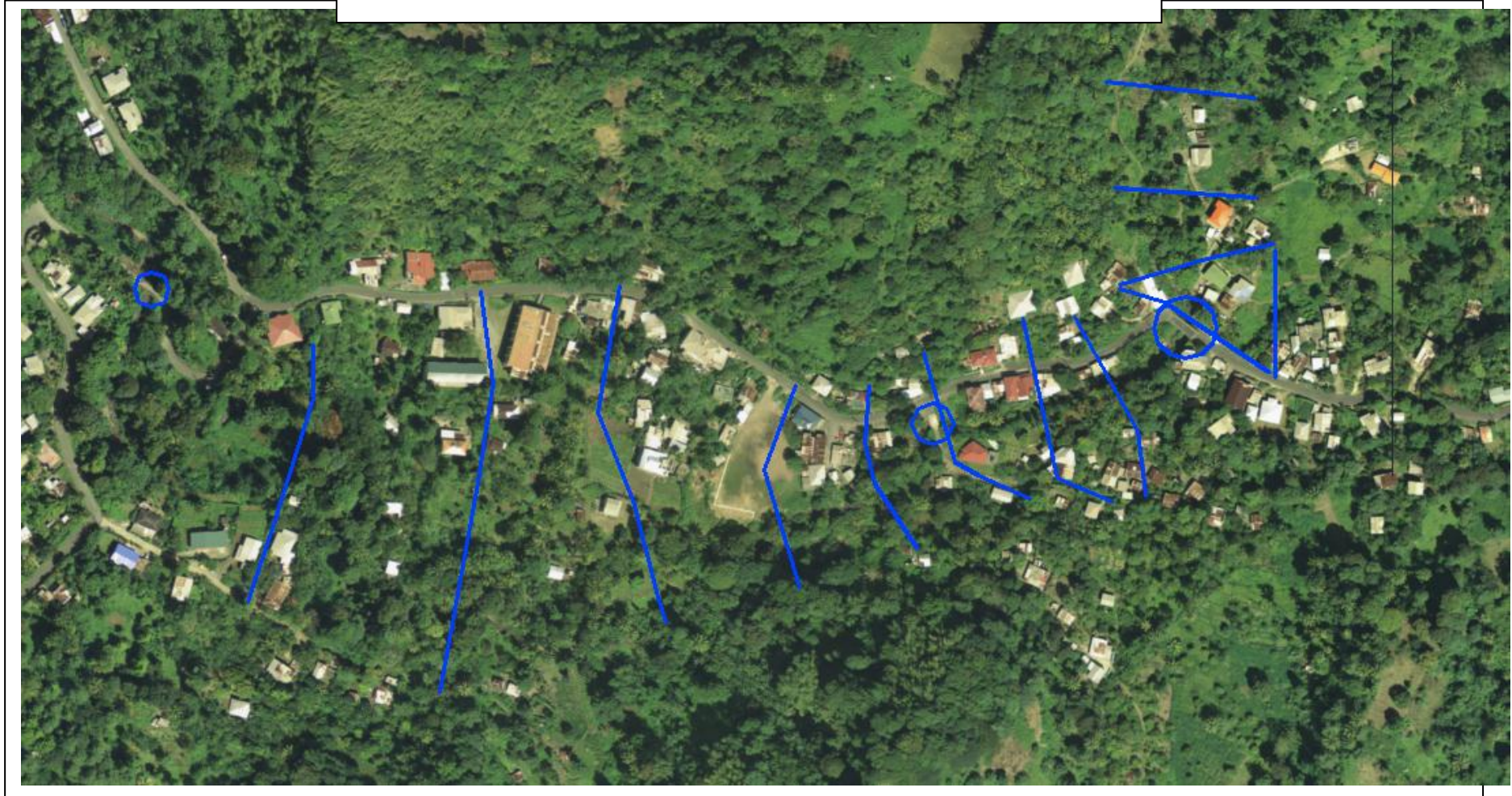

Cross sections and bridges structures localization in SOUFRIERE

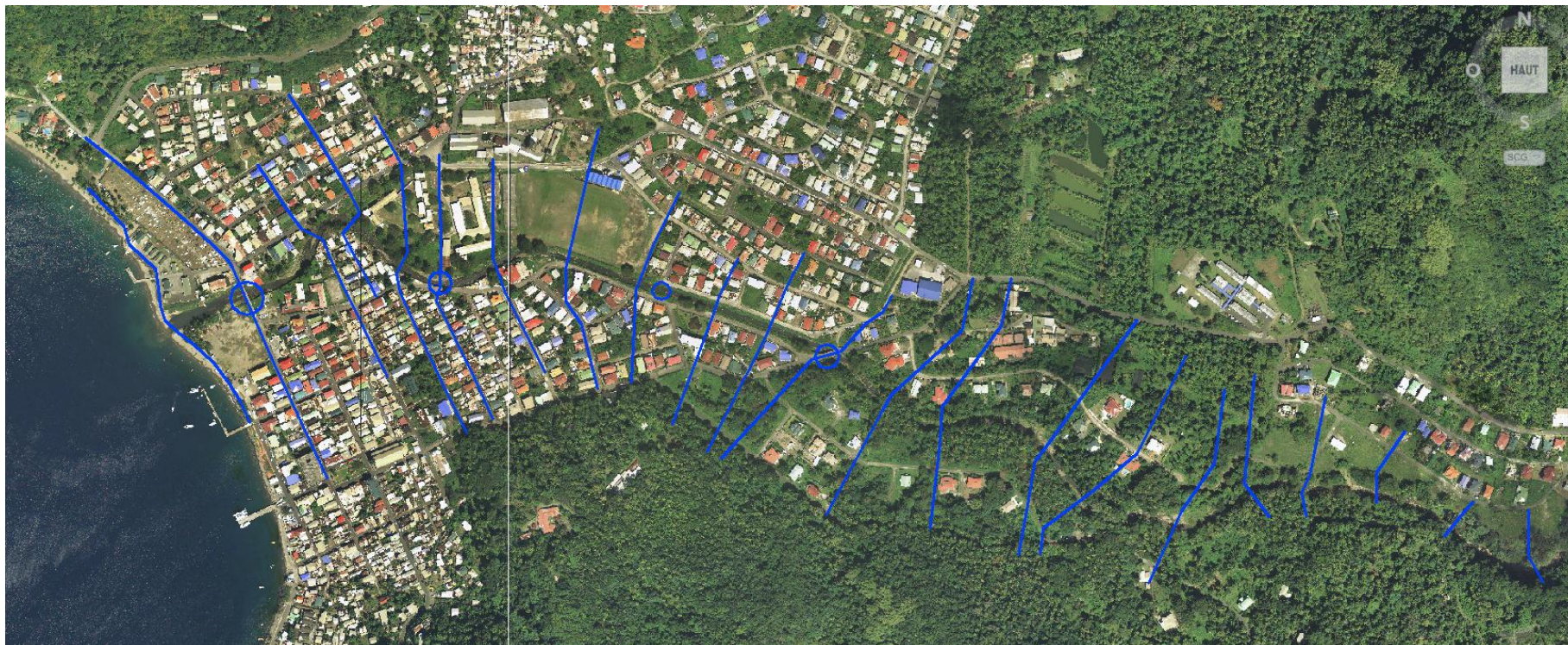

Cross sections and bridges structures localization in DENNERY

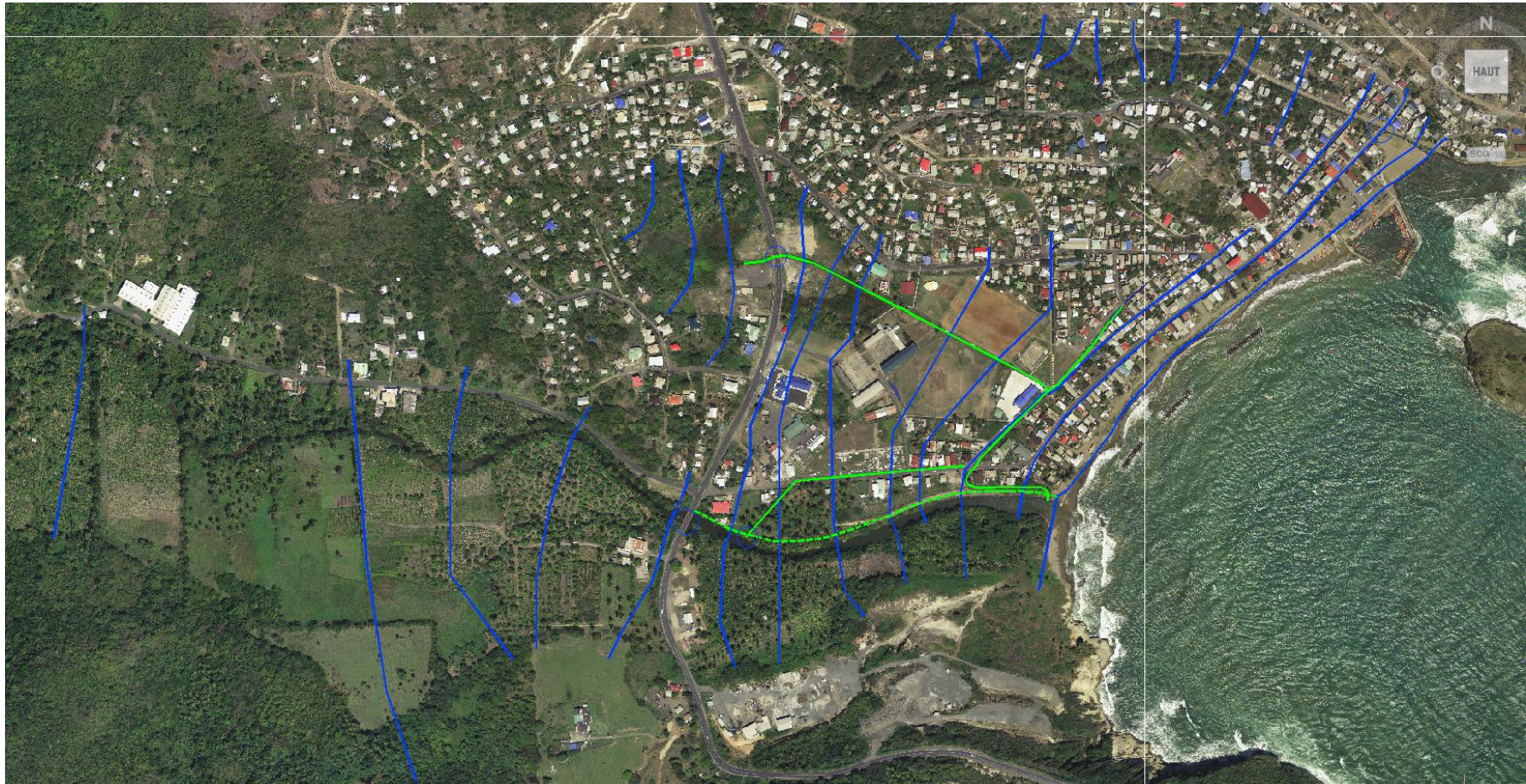

Chapter 4. Water level during Thomas

4.1 Localization

The Water level during Thomas Hurricane analysis concerns two areas: Fond Saint Jacques and Dennery :

- 4 Water levels in Fond Saint Jacques,
- 4 Water levels in Dennery

4.2 Scope of services

A / In Fond Saint Jacques

1. Point 1 : 2 levels to measure

Water Level 1 Fond St Jacques	P
Latitude :	13°50'8.36"N
Longitude :	61° 1'24.63"O



Take the highest level of the mud and the dirt level inside the house



2. Point 2 : 1 level to measure

Water Level 2 - Fohd Saint Jacques

Latitude : 13°50'10.23"N

Longitude : 61° 1'23.22"O



Take the level of the mud at the first floor

3. Point 3 : 1 level to measure

Water Level 3 - Fond Saint Jacques

Latitude : 13°50'11.71"N

Longitude : 61° 1'20.05"O



Take the level of dirt inside the broken house



B / In Soufrière

No water level during Tomas to measure

C / In Dennery

1. Point 1 : 1 level to measure

Water Level 1 - Dennery		P
Latitude :	13°54'43.64"N	
Longitude :	60°53'12.98"O	



Measure the floor level of the restaurant

2. Point 2 : 1 level to measure

Water Level 2 - Dennergy| 

Latitude :

Longitude :



Measure the level of the last stair before the floor of the house right bank

3. Point 3 : 1 level to measure

Water Level 3 - Denney

Latitude : 13°54'49.24"N

Longitude : 60°53'19.87"O



Measure the level shown on the pilar with the blue trace under the house left bank

4. Point 4 : 1 level to measure

Water Level 4 | Dennerly P

Latitude : 13°54'35.99"N

Longitude : 60°53'25.76"O



Measure the level shown

Chapter 5. Provided results

The metric system will be used.

5.1 Planimetry, altimetry

All result will be localized in the local planimetry system. The System will be precised.

Altimetric precision required: ± 2 cm

Planimetric precision required: ± 10 cm

5.2 Type of data

For the map and geometrical draw: Autocad 3D (.dwg) files;

All coordinates measures in an Excel File, three columns X, Y and Z per profile, cross section and hydraulic structure.

A global map will be provided for each studied area in wich will be localized the data.



- Études générales
- Assistance au Maître d'Ouvrage
- Maîtrise d'œuvre conception
- Maîtrise d'œuvre travaux
- Formation

Egis Eau Siège social
78, allée John Napier
CS 89017
34965 - Montpellier Cedex 2
Tél. : 04 67 99 22 00
Fax : 04 67 65 03 18
montpellier.egis-eau@egis.fr
<http://www.egis-eau.fr>

